

HYDAC INTERNATIONAL

Pilot-operated Check Valves ERVE

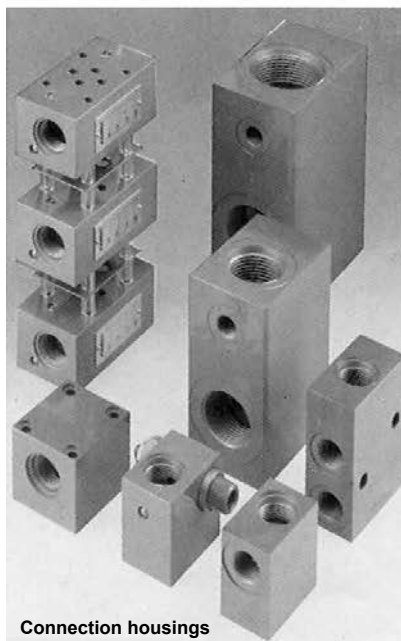
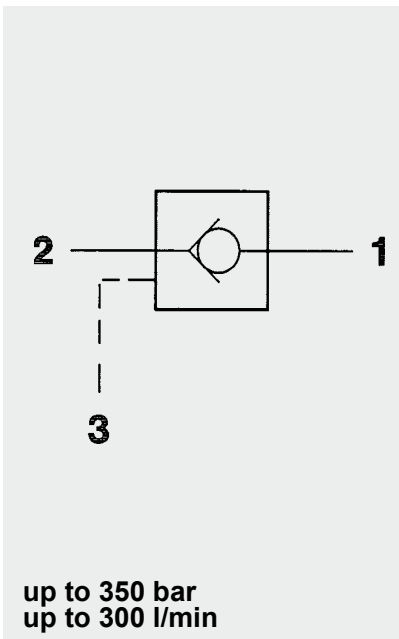

E 5.172.8/12.10

1. DESCRIPTION

1.1. GENERAL

In accordance with DIN-ISO 1219, HYDAC pilot-operated check valves, type ERVE, are check valves for oil-hydraulic systems, on which the shut-off function can be cancelled hydraulically. Due to the seat valve construction, the valve is leakage-free in the shut-off position.

Advantages are:

- leak-free in shut-off direction 1 → 2, the appliances are kept in position
- compact construction enables mounting into cylinders, housings etc
- three sizes for a range of different applications
- 2 sizes with two-stage operation to avoid shocks during the relief of pressurized fluids
- inline housings are available for all sizes

1.2. OPERATION

HYDAC pilot-operated check valves, type ERVE, size R ½ are direct operated, and size R 1 and R 1 ½ are two-stage.

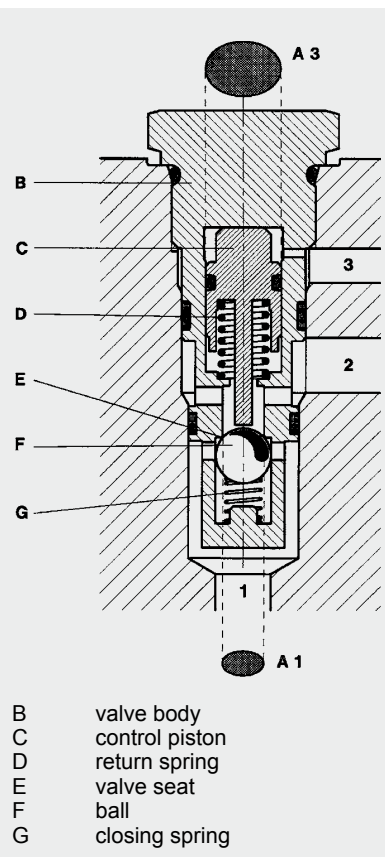

1.2.1 ERVE-R ½

(direct operated)

HYDAC pilot-operated check valves, size ERVE R ½, are direct operated ball seat valves for oil-hydraulic systems. They allow free flow in direction 2 → 1.

In the opposite direction the ball is pushed against the valve seat by the closing spring and the pressure across port 1 and shuts off the flow in direction 1 → 2 leak-free. By introducing a sufficiently high control pressure across port 3 (see 2.2.10) the control piston is moved and the ball is pushed away from the valve seat; the shut-off function

is cancelled and flow can go from 1 → 2. The return spring fitted underneath the control piston allows an inertialess return if pressure is released across control port 3. On the control piston the pressure across port 2 counteracts the control pressure across port 3. Therefore there must be no pressure across port 2 during the hydraulic cancellation of the shut-off function.

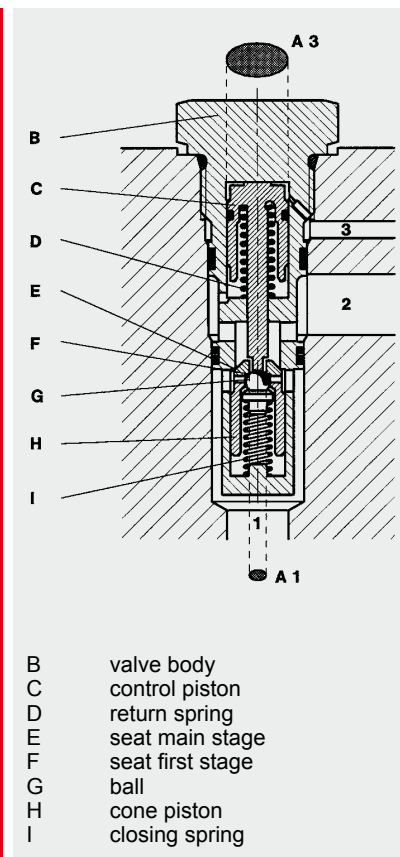

1.2.2 ERVE-R 1 and ERVE-R 1 ½

(two-stage)

HYDAC pilot-operated check valves, size ERVE R 1 and ERVE R 1 ½, are valves with first stage decompression. For free flow from 2 → 1, the main stage and the first stage are pushed simultaneously against the closing spring and therefore clear the necessary cross section on the seat of the main stage.

In the opposite direction, the ball and the cone piston are pushed against the seats by the closing spring and the pressure across port 1; the connection from 1 to 2 is shut-off leakage-free.

By introducing a sufficiently high control pressure across port 3 (see 2.2.10) the seat of the first stage is opened; this leads to a damped relief of the pressurized fluid. Due to the further stroke of the control piston the main stage is then opened and flow can go from 1 to 2. On the control piston, the pressure across port 2 counteracts the control pressure across port 3. Therefore there must be no pressure across port 2 during the hydraulic cancellation of the shut-off function.

1.3. APPLICATION

HYDAC pilot-operated check valves, type ERVE, are suitable for:

- prevention of creeping movement of loaded cylinders which are operated by spool valves
- shut-off or cancellation of pressurised units, e.g. press cylinders
- prevention of uncontrolled movement of loaded appliances, e.g. during hose breaks or pump failure

Applications are for example:

- injection moulding machines
- lifting platforms
- support cylinders
- mobile hydraulics
- hydraulic tensioning
- handling devices

1.4. RECOMMENDATIONS

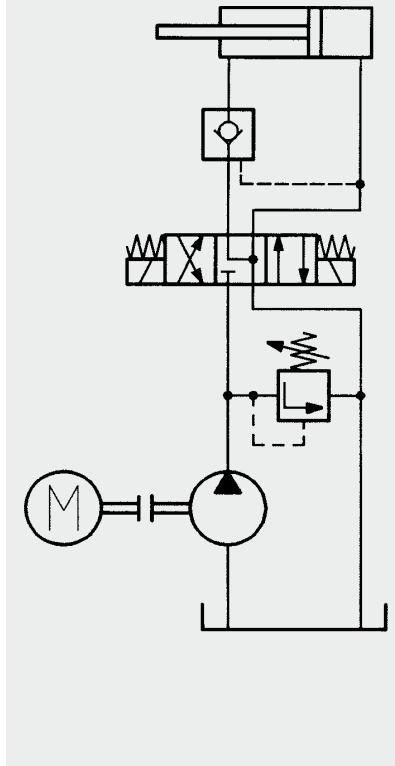

When fitting the valves to control blocks and housings, the recommended torque ratings must be observed.

Pressure across port 2 counteracts the pressure across port 3 required for pilot operation! (see 2.2.10 control pressure p_{co})

If an appliance has to be kept in a particular position, the control line in port 3 must be released by selecting an appropriate spool valve, to ensure safe closing of the valves.

2. TECHNICAL SPECIFICATIONS

2.1. GENERAL

2.1.1 Designation and symbol Pilot-operated check valve

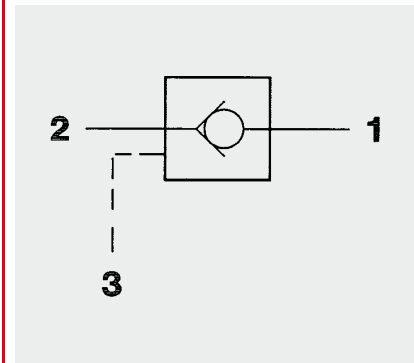



2.1.2 Model Code (also order example)

ERVE - R ½ - 10 X

Pilot-operated check valve

Size

- R ½"
- R 1"
- R 1½"

Type

10 = standard

Series

(determined by manufacturer)

Standard models

Stock no. (= order code)	Model code
717555	ERVE-R ½ - 10 X
717556	ERVE-R 1 - 10 X
717557	ERVE-R 1 ½ - 10 X

When ordering, please quote stock no.

Delivery for non-standard models is longer and the price is higher.

2.1.3 Construction

Seat valve (direct-operated)
(ERVE-R ½)
Seat valve (two-stage)
(ERVE-R 1, ERVE-R 1 ½)

2.1.4 Mounting type

Cartridge valve

2.1.5 Mounting position

Optional

2.1.6 Weight

ERVE-R ½ ... 0.10 kg
ERVE-R 1 ... 0.45 kg
ERVE-R 1 ½ ... 1.40 kg

2.1.7 Flow direction

From 2 to 1 free flow
From 1 to 2 leak-free shut-off;
shut-off position can
be cancelled hydraulically (pres-
sure across port 3)

2.1.8 Ambient temperature range

- 20 °C min.
+ 80 °C max.

2.1.9 Materials

Valve body: free-cutting steel
Closing element: hardened
and polished steel
Seals: FPM and PTFE

2.1.10 Type of connection

Suitable connection housings
with installation dimensions
08021, 16021 and 20021 are
available. See separate housing
brochure no. E 5.252../..

2.2. HYDRAULIC DETAILS

2.2.1 Nominal pressure

$p_N = 350$ bar
across all ports

2.2.2 Pressure fluid

Mineral oil to DIN 51524,
parts 1 and 2

2.2.3 Pressure fluid temperature range

- 20 °C min.
+ 80 °C max.

2.2.4 Viscosity range

10 mm²/s min.
380 mm²/s max.

2.2.5 Filtration

Max. permissible contamination
rate of the operating fluid to
ISO 4406 class 21/19/16
(NAS 1638 class 10).
We recommend a filter with a
minimum retention rate
of $\beta_{20} \geq 100$.

The fitting of filters and regular
replacement of the filter element
ensures correct functioning, redu-
ces wear and tear and increases
the service life.

2.2.6 Pressure drop, dependent on flow rate measured at 36 mm²/s and t_{oil} = 50 °C

ERVE-R ½

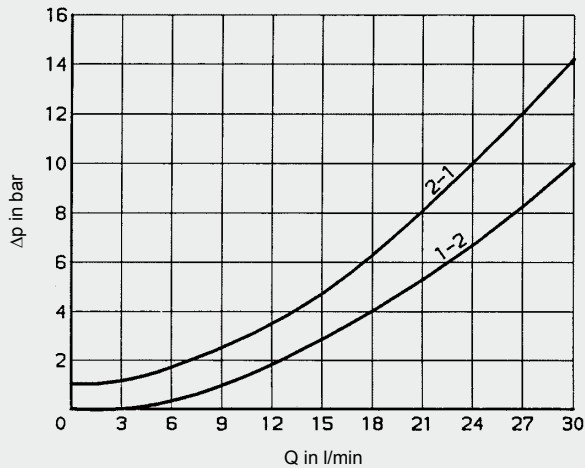

ERVE-R 1

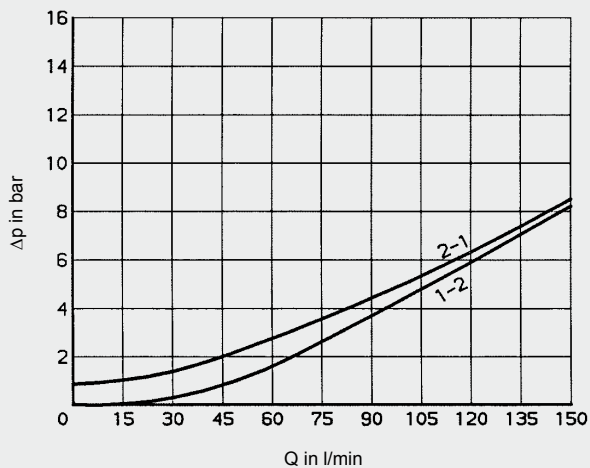

ERVE-R 1 ½

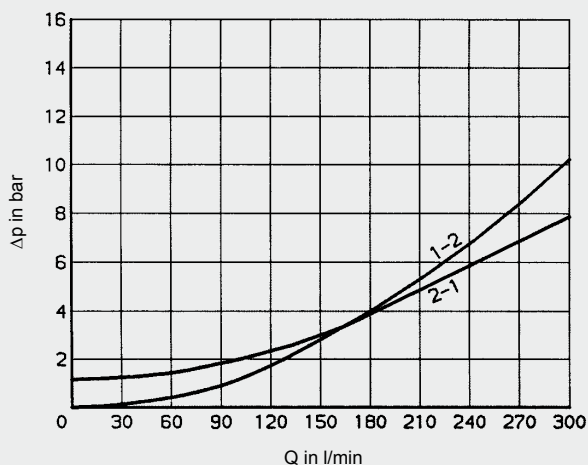

2.2.7 Cracking pressure

Flow direction 2 to 1:

p₀ = 1 bar

2.2.8 Control volume

ERVE-R ½ ... V_{co} = 0.3 cm³

ERVE-R 1 ... V_{co} = 1.55 cm³

ERVE-R 1 ½ ... V_{co} = 3.3 cm³

2.2.9 Control area ratio

$\varphi = \frac{A_3}{A_1}$ (see sectional drawings, point 1.2.)

ERVE-R ½ ... $\varphi = 3.4$

ERVE-R 1 ... $\varphi = 13$

ERVE-R 1 ½ ... $\varphi = 13.4$

For calculation of the required control pressure p_{co} across port 3 see point 2.2.10.

2.2.10 Control pressure p_{co}

Calculation of the required control pressure p_{co} across port 3 to cancel the shut-off function of the valve (flow 1 to 2) while port 2 is unpressurized.

p_{co}: ... required control pressure in bar across port 3 to cancel shut-off function

p₂: ... pressure across port 2 in bar

p₁: ... pressure across port 1 in bar

Δp: ... pressure differential 1 to 2 from diagram 2.2.6

Type	Cancellation main stage	Cancellation first stage	Keep open
ERVE-R ½	p _{co} = 0.3p ₁ +2.5		p _{co} = p ₂ +Δp+4.5
ERVE-R 1	p _{co} = 0.55p ₁ +2.5	p _{co} = 0.08p ₁ +3	p _{co} = p ₂ +Δp+5
ERVE-R 1 ½	p _{co} = p ₁ +3.5	p _{co} = 0.08p ₁ +4	p _{co} = p ₂ +Δp+6

3. DIMENSIONS

ERVE

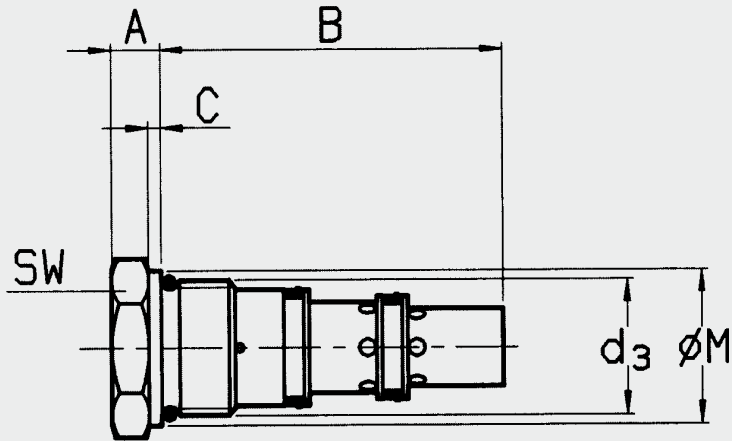

Size	d ₃	A	B	C	ØM	SW	Torque
ERVE-R ½	G ½	8	56	2	24	24	25 ⁺⁵ Nm
ERVE-R 1	G 1	16	100	3	40	41	150 ⁺¹⁰ Nm
ERVE-R 1 ½	G 1 ½	20	125	3	54	55	150 ⁺¹⁰ Nm

3.1. INSTALLATION DIMENSIONS FOR CARTRIDGE VALVES

Installation dimensions 08021 (ERVE-R ½)

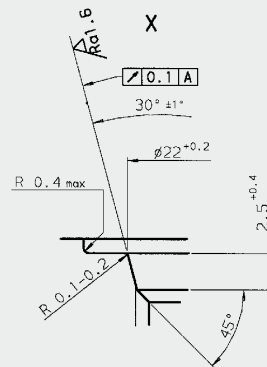
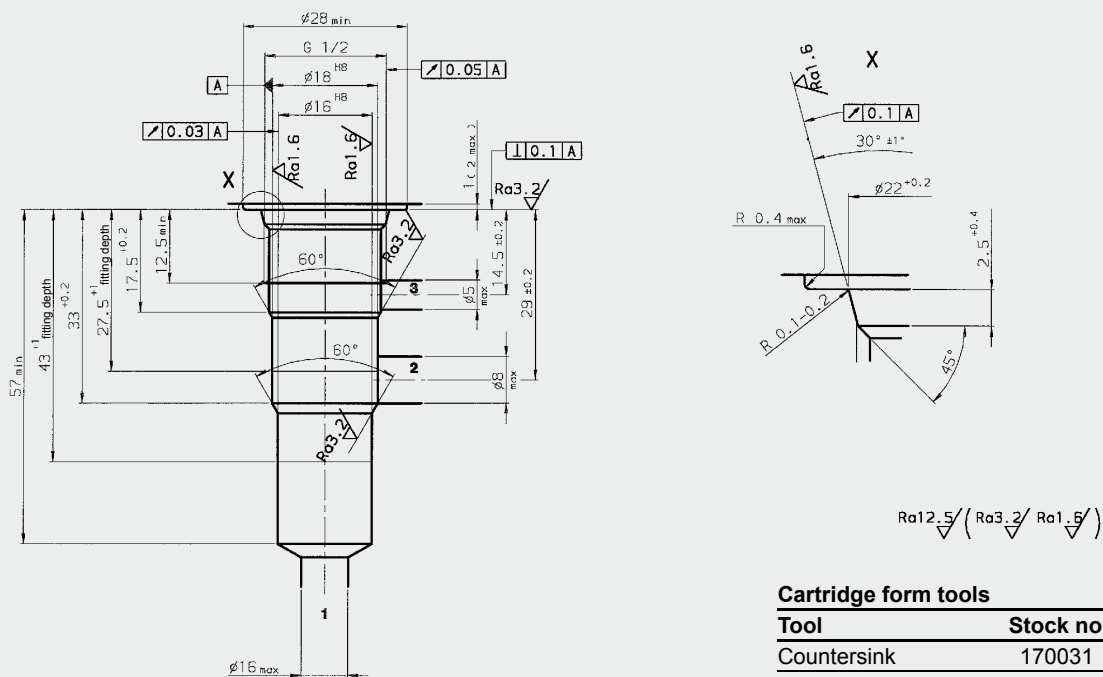

Cartridge form tools

Tool	Stock no.
Countersink	170031
Reamer	169962
Tap	1002667
Plug gauge	169939

E 5.172.8/12.10

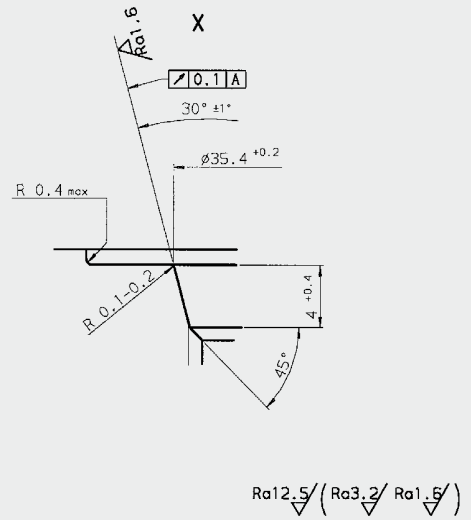
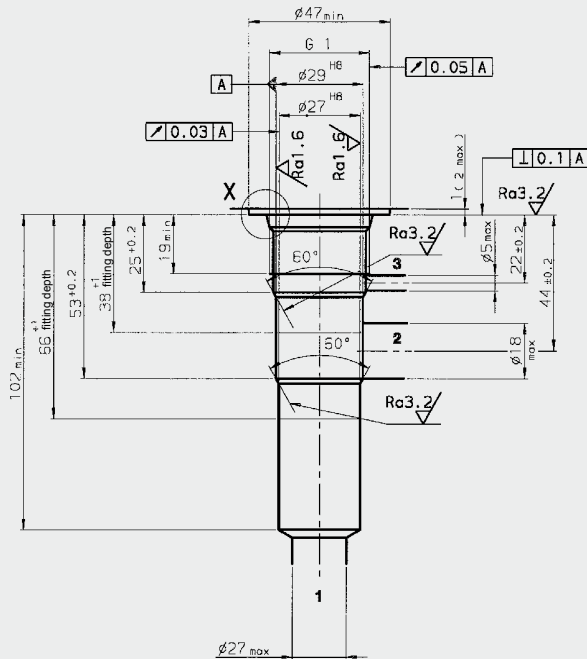
Installation dimensions 16021 (ERVE-R 1)

Cartridge form tools

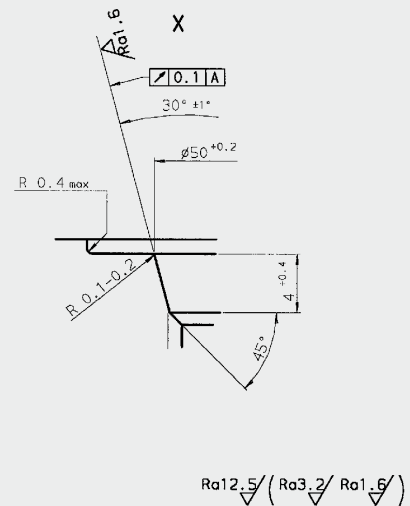
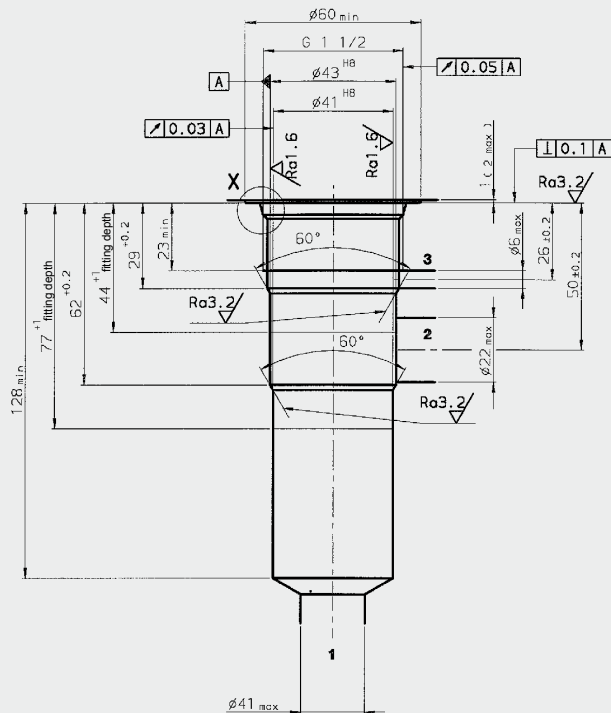
Tool	Stock no.
Countersink	170035
Reamer	169965
Tap	1002661
Plug gauge	174879

Installation dimensions 20021 (ERVE-R 1 1/2)

Cartridge form tools

Tool	Stock no.
Countersink	170034
Reamer	169966
Tap	1002524
Plug gauge	174880

