

Pressure reducing valve, direct operated

RE 26570/05.11
Replaces: 02.03

1/8

Type ZDR

Size 6
Component series 4X
Maximum operating pressure 210 bar
Maximum flow 50 l/min



Table of contents

Contents	Page
Features	1
Ordering code	2
Symbols	2
Function, section	3
Technical data	4
Characteristic curves	5
Unit dimensions	6, 7

Features

- Sandwich plate valve
- Porting pattern according to DIN 24340 form A
- Porting pattern according to ISO 4401-03-02-0-05 (with locating hole)
- 4 pressure ratings
- 4 adjustment types:
 - Rotary knob
 - Bushing with hexagon and protective cap
 - Lockable rotary knob with scale
 - Rotary knob with scale
- Pressure reduction in channel A, B or channel P
- Check valve, optional (only version "A")

Information on available spare parts:
www.boschrexroth.com/spc

Archivierung: 07/2012

Ordering code

Z	DR	6	D		-4X/	Y			*
Further details in the plain text									
No code = Without locating hole /60²⁾ = With locating hole /62 = With locating hole and locating pin ISO 8752-3x8-St									
Seal material No code = NBR seals V = FKM seals (other seals upon request) Attention! Observe compatibility of seals with hydraulic fluid used!									
No code = With check valve (only with version "A") M = Without check valve									
Y = Pilot oil supply internal, pilot oil return external									
25 = Secondary pressure up to 25 bar 75 = Secondary pressure up to 75 bar 150 = Secondary pressure up to 150 bar 210 = Secondary pressure up to 210 bar									
Sandwich plate Pressure reducing valve Size 6 = 6 Direct operated Pressure reduction in channel A ^② = A Pressure reduction in channel B ^② = B Pressure reduction in channel P ^① = P Adjustment type Rotary knob = 1 Bushing with hexagon and protective cap = 2 Lockable rotary knob with scale = 3 ¹⁾ Rotary knob with scale = 7 Component series 40 to 49 = 4X (40 to 49: unchanged installation and connection dimensions)									

¹⁾ H key with material no. **R900008158** is included in the delivery.

²⁾ Locating pin ISO 8752-3x8-St, Material no. **R900005694** (separate order)

Standard types and standard units are contained in the EPS (standard price list).

Symbols (① = component side, ② = plate side)

Type ZDR 6 DP...YM...

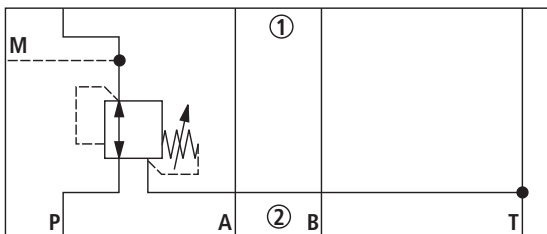

Type ZDR 6 DA...YM...

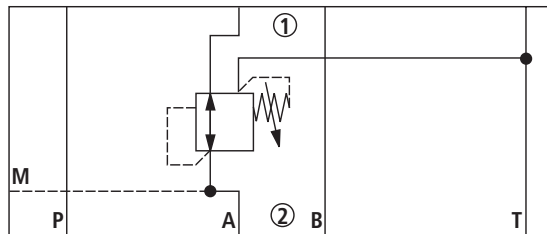

Type ZDR 6 DB...YM...

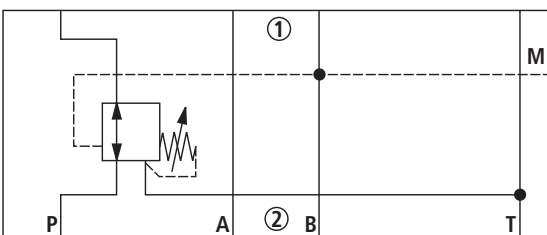

Type ZDR 6 DA...Y...

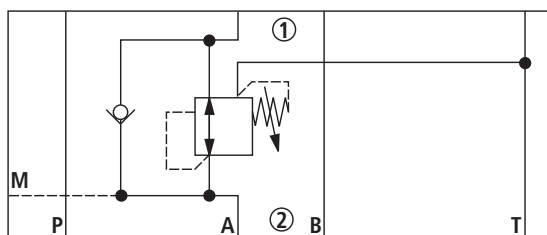

Archivierung: 07/2012

Function, section

The valve type ZDR is a direct operated pressure reducing valve in sandwich plate design with pressure limitation of the secondary circuit. It is used to reduce the system pressure.

The pressure reducing valve basically comprises of a housing (1), a control spool (2), a compression spring (3), adjustment type (4) and an optional check valve.

The secondary pressure is set via the adjustment type (4).

Version "A"

In the initial position the valve is open. Hydraulic fluid can flow from channel A① to channel A② without limitation. Via the pilot line (5), the pressure in channel A② is simultaneously applied to the spool face vis-à-vis the compression spring (3). If the pressure in channel A② rises above the value set at the compression spring (3), the control spool (2) moves against the compression spring (3) into the control position and thereby holds the set pressure in channel A② constant.

Control signal and pilot oil are provided internally, via the control line (5), from channel A②.

If the pressure in channel A② continues to increase due to external forces at the actuator, the control spool (2) moves further against the compression spring (3).

Thus, channel A② is, via control edge (9) at the control spool (2) and housing (1) connected with the tank. Hydraulic fluid continues to flow to the tank until the pressure no longer increases.

The leakage oil drain from the spring chamber (7) is always realized externally, via bore (6) and channel T (Y).

A pressure gauge connection (8) allows for the control of the secondary pressure at the valve.

With version "A", a check valve can be used for free flow back from channel A② to A①.

Versions "P" and "B"

With version "P", the pressure is reduced in channel P①. Control signal and pilot oil are provided internally, from channel P①.

With version "B", the pressure is reduced in channel P①, the pilot oil is, however, taken from channel B.

Attention!

If the directional valve is in spool position P to A, the pressure in channel B must not exceed the set secondary pressure. Otherwise, the pressure in channel A will be reduced.

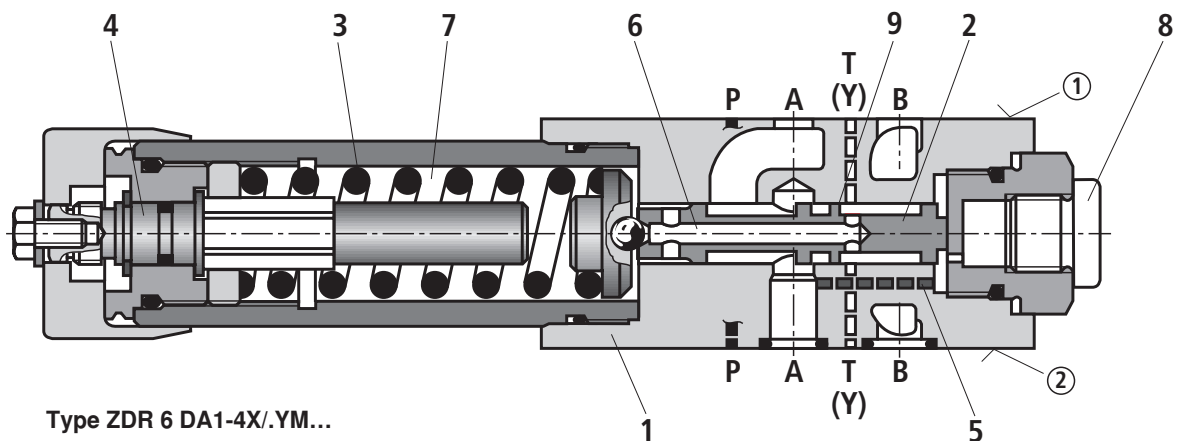

① = component side

② = plate side

Technical data (For applications outside these parameters, please consult us!)

general

Weight	kg	Approx. 1.2
Installation position		Any
Ambient temperature range	°C	-30 to +80 (NBR seals) -20 to +80 (FKM seals)

hydraulic

Maximum operating pressure – Input	bar	315
Maximum secondary pressure – Output	bar	25; 75; 150; 210
Maximum backpressure – Port T(Y)	bar	160
Maximum flow	l/min	50
Hydraulic fluid		See table below
Hydraulic fluid temperature range	°C	-30 to +80 (NBR seals) -20 to +80 (FKM seals)
Viscosity range	mm ² /s	10 to 800
Maximum permitted degree of contamination of the hydraulic fluid - cleanliness class according to ISO 4406 (c)		Class 20/18/15 ¹⁾

Hydraulic fluid	Classification	Suitable sealing materials	Standards	
Mineral oils and related hydrocarbons	HL, HLP, HLPD	NBR, FKM	DIN 51524	
Environmentally compatible	– Insoluble in water	HETG	ISO 15380	
		HEES		FKM
Flame-resistant	– Soluble in water	HEPG	ISO 15380	
	– Water-free	HFDU, HFDR	FKM	ISO 12922
	– Water-containing	HFC (Fuchs Hydrotherm 46M, Petrofer Ultra Safe 620)	NBR	ISO 12922

 Important information on hydraulic fluids! – For more information and data on the use of other hydraulic fluids refer to data sheet 90220 or contact us! – There may be limitations regarding the technical valve data (temperature, pressure range, service life, maintenance intervals, etc.)!	– Flame-resistant – water-containing: <ul style="list-style-type: none"> • Maximum operating pressure 210 bar • Maximum hydraulic fluid temperature 60 °C • Expected service life as compared to HLP hydraulic oil 30 % to 100 %
--	--

¹⁾ The cleanliness classes specified for the components must be adhered to in hydraulic systems. Effective filtration prevents faults and at the same time increases the service life of the components.

For the selection of the filters see www.boschrexroth.com/filter.

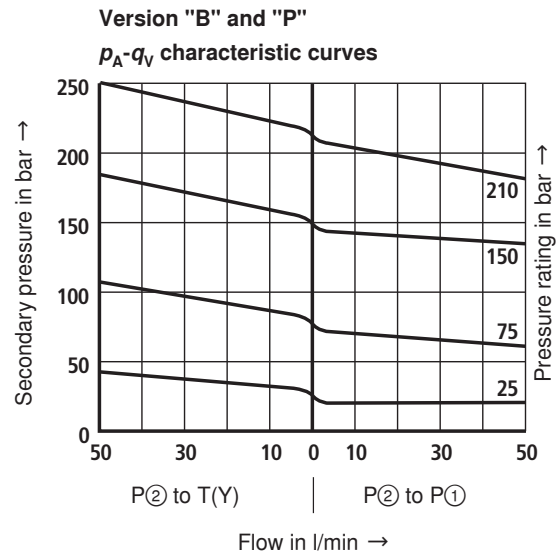
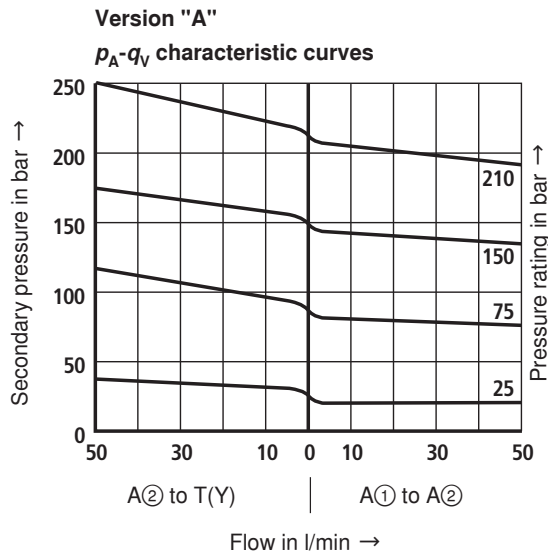
Characteristic curves (measured with HLP46, $\vartheta_{\text{oil}} = 40 \pm 5 \text{ }^\circ\text{C}$)

Note!

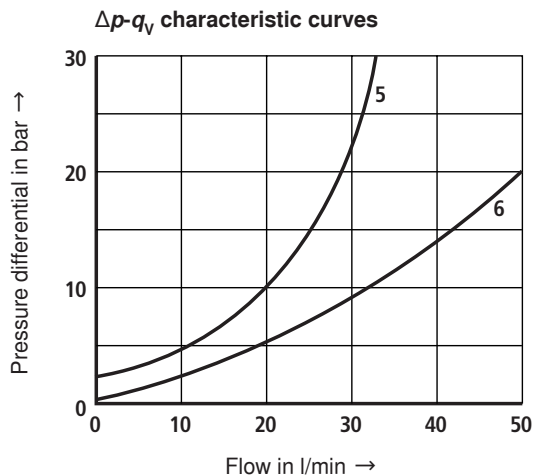
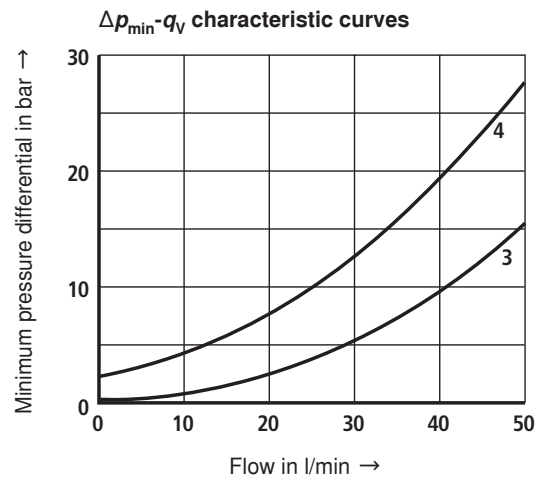
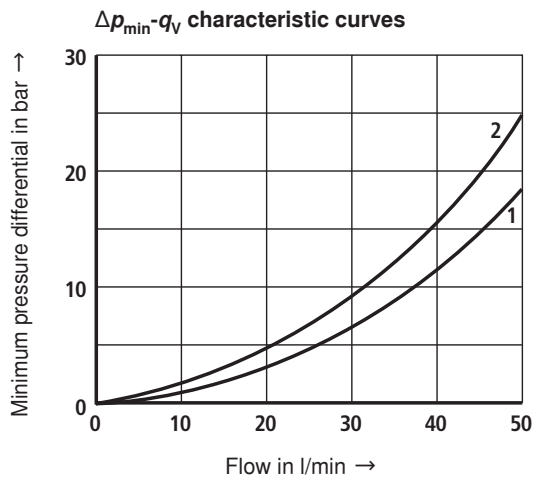
The curve development is maintained according to the pressure rating if the pressure is set lower.



- 1 A① to A②
- 2 A② to T(Y) (3rd way)
- 3 P② to P①
- 4 P① to T(Y) (3rd way)
- 5 A② to A①; flow only via check valve
- 6 A② to A①; flow via check valve and completely opened control cross-section

The characteristic curves apply to the pressure at the valve output $p_T = 0$ bar across the entire flow range.

Archivierung: 07/2012

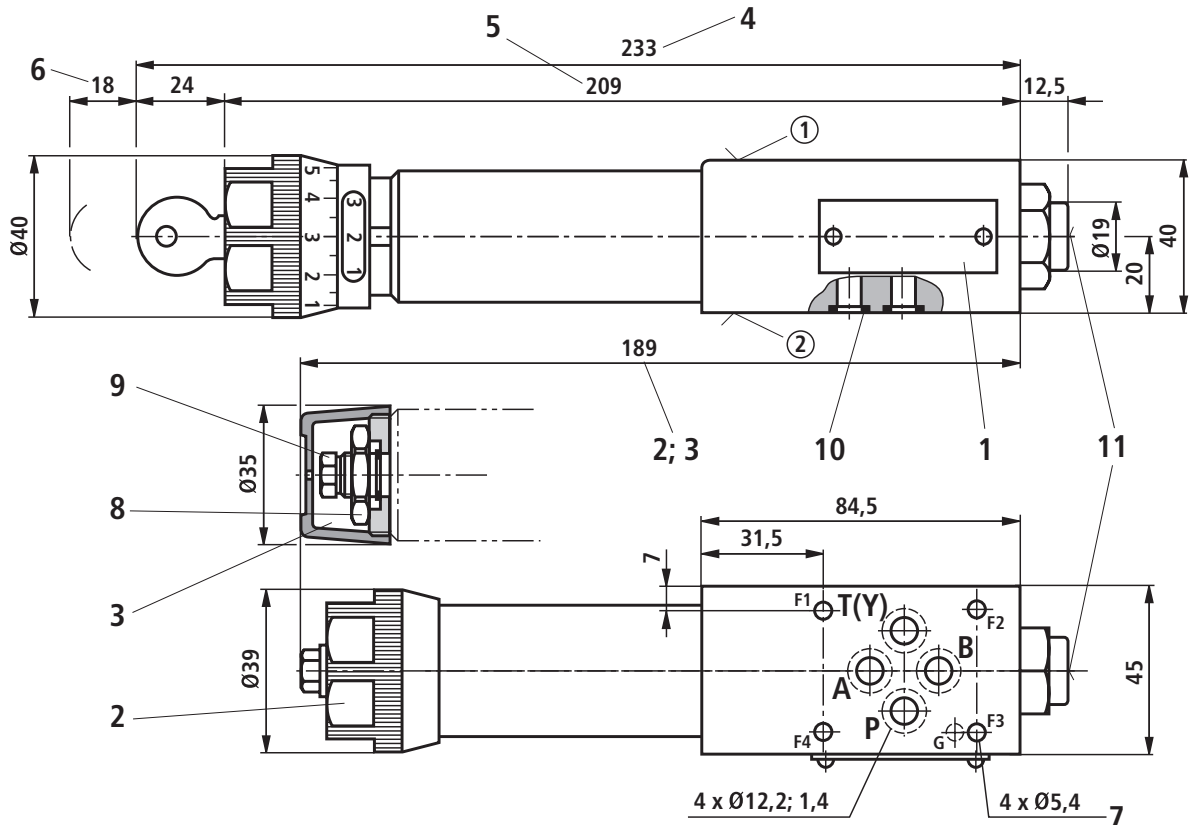
Unit dimensions: Version "A" (dimensions in mm)

- ① Component side – porting pattern according to DIN 24340 form A (**without** locating hole), or ISO 4401-03-02-0-05 (**with** locating hole $\varnothing 3 \times 5$ mm deep)
- ② Plate side – porting pattern according to DIN 24340 form A (**without** locating hole), or ISO 4401-03-02-0-05 (**with** locating hole for locating pin ISO 8752-3x8-St; version "/60")

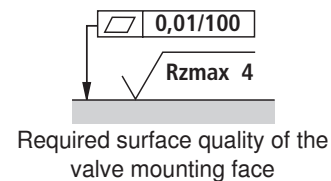

- 1 Name plate
- 2 Adjustment type "1"
- 3 Adjustment type "2"
- 4 Adjustment type "3"
- 5 Adjustment type "7"
- 6 Space required to remove the key
- 7 Valve mounting bores
- 8 Lock nut SW24
- 9 Hexagon SW10
- 10 Identical seal rings for ports A, B, P, T(Y)
- 11 Pressure gauge connection G1/4; 12 deep; internal hexagon SW6

Valve mounting screws (separate order)

4 hexagon socket head cap screws ISO 4762 - M5 - 10.9

 **Note!**

Length and tightening torque of the valve mounting screws must be calculated according to the components mounted under and over the sandwich plate valve.

