

Hydro-electric pressure switch

RE 50061/02.12
Replaces: 07.06

1/16

Type HED 8

Component series 2X
Maximum operating pressure 630 bar
CE, CCC, UL



TB0004+TB0040

Table of contents

Contents	Page
Features	1
Ordering code	2
Function, sections, symbol	3
Technical data	4
Characteristic curves Switching pressure differential	6
Unit dimensions	7
Installation information	10
Ordering code: Sandwich plate size 6	12
Symbols, variant no.: Sandwich plate size 6	12
Unit dimensions: Sandwich plate size 6	13
Ordering code: Sandwich plate size 10	14
Symbols, variant no.: Sandwich plate size 10	14
Unit dimensions: Sandwich plate size 10	15
Electrical connection	16
Mating connectors	16

Features

- For subplate mounting/pipeline installation
- For flange connection according to ISO 16873
- As vertical stacking element in connection with sandwich plates according to ISO 4401
- 5 pressure ratings
- 4 adjustment types:
 - Spindle with/without protective cap
 - Spindle with scale, with/without protective cap
 - Rotary knob with scale
 - Lockable rotary knob with scale
- Electrical connection
 - with large cubic connector
 - with M12 x 1 connector
- Micro switch with NC/NO contact function
- Potential-free switching of currents from 1 mA to 2 A
- UL approval for pressure ranges up to 350 bar

Ordering code

HED 8		-2X/					*
Piston type pressure switch							Further details in the plain text
Flange connection (ISO 16873) ¹⁾	= OH						Seal material
Subplate mounting	= OP						NBR seals
Pipeline installation	= OA						FKM seals
Component series 20 to 29 (20 to 29: Unchanged installation and connection dimensions)		= 2X					Low-temperature seals (max. 315 bar)
Pressure rating maximum 50 bar			= 50				Notice:
Pressure rating maximum 100 bar			= 100				Observe compatibility of seals with the hydraulic fluids used.
Pressure rating maximum 200 bar			= 200				Adjustment type
Pressure rating maximum 350 bar			= 350				no code = Spindle with internal hexagon, without scale, without protective cap
Pressure rating maximum 630 bar ²⁾			= 630				S = Spindle with internal hexagon, without scale, with protective cap, can be sealed
Electrical connection							A ⁵⁾ = Spindle with scale, without protective cap
Individual connection with connector according to DIN EN 175301-803, large cubic connector without mating connector ³⁾				= K14 ³⁾			AS ⁵⁾ = Spindle with scale, with protective cap
Individual connection with connector according to IEC 61076-2-101, M12 x 1, A-coding without mating connector ³⁾				= K35 ³⁾			KS ^{4; 5)} = Lockable rotary knob with scale
							KW ⁵⁾ = Rotary knob with scale

- ¹⁾ Sandwich plate for vertical stacking, separate order see accessories
- ²⁾ Not admissible for vertical stacking, not with low-temperature seals, without UL approval
- ³⁾ Mating connectors, separate order, see accessories
- ⁴⁾ H-key, material no. **R900008158**, is included in the scope of delivery
- ⁵⁾ The exact setting of the switching pressure is only possible using a pressure gauge (scale is used as orientation)

Accessories

- Sandwich plates for the vertical stacking see page 12 and 14.
- Mating connectors for the electrical connection see page 16.

Function, sections, symbol

The hydro-electric pressure switch type HED 8 is a piston type pressure switch. It basically comprises of housing (1), installation kit with piston (2), compression spring (3), adjustment element (4) and micro switch (5).

If the pressure to be monitored is below the set pressure, the micro switch (5) is operated. The pressure to be monitored is applied via the nozzle (7) at the piston (2). The piston (2) is supported by the spring plate (6) and acts against the continuously adjustable force of the compression spring (3). The spring plate (6) transmits the movement of the piston (2) onto the micro switch (5) and releases the latter when the set pressure is reached. This switches the electric circuit on or off, depending on the circuit set-up. The mechanical positive stop of the spring plate (6) protects the micro switch (5) in case of a sudden pressure drop from mechanical destruction and, in case of overpressure, prevents solid compression of the compression spring (3).

Notice:

In order to increase the service life, the pressure switch should be mounted with low vibrations and protected from hydraulic pressure surges.

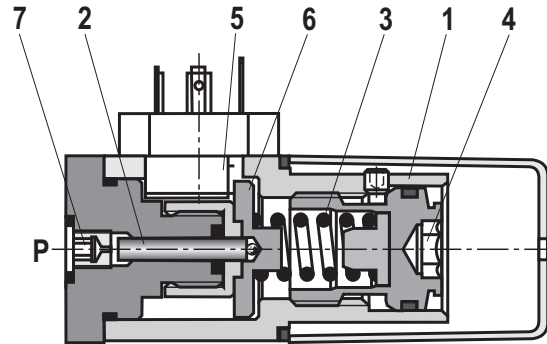

Type HED 8 OH-2X/...K14
 Type HED 8 OH-2X/...K14S

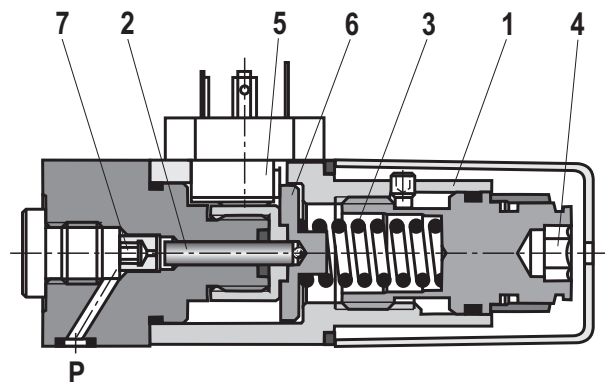

Type HED 8 OP-2X/...K14A
 Type HED 8 OP-2X/...K14AS

Symbol

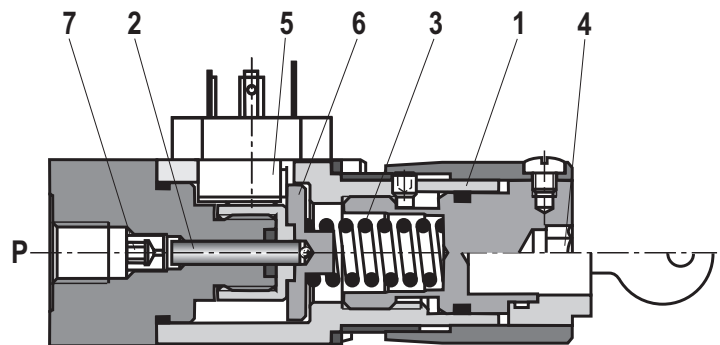
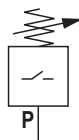

Type HED 8 OA-2X/...K14KW
 Type HED 8 OA-2X/...K14KS

Technical data (For applications outside these parameters, please consult us!)

general

Weight	kg	0.8
Installation position		Any
Ambient temperature range		-25 to +50 (NBR seals) -20 to +50 (FKM seals) -40 to +50 (low-temperature seals)
Sine test according to DIN EN 60068-2-6:1996-05		5...2000 Hz, max. 10 g, 10 double cycles
Transport shock according to DIN EN 60068-2-27:1995-03		15 g / 11 ms
Bump test according to DIN EN 60068-2-29:1995-03		25 g / 6 ms
Noise test according to DIN EN 60068-2-64:1996-05		20...2000 Hz, 10 g _{RMS} , 30 min
Conformity	CE	DIN EN 61058-1: 2008-09-05 IEC 60947-5-1: 2010-04 DIN EN 60529: 2000-09
	UL	UL 508 17th edition File No E223220
	CCC	EN 61058-1:1993 IEC 60947-5-1

hydraulic

Pressure rating	bar	50	100	200	350	630
Maximum operating pressure						
NBR/FKM seals	bar	350	350	350	400	630
MT version	bar	315	315	315	315	–
Pressure adjustment range (decreasing)	bar	5...50	10...100	15...200	25...350	40...630
Pressure differential per rotation ¹⁾	bar	≈19	≈35	≈77	≈120	≈214
Hydraulic fluid		Mineral oil (HL, HLP) according to DIN 51524 ²⁾ ; fast biodegradable hydraulic fluids according to VDMA 24568 (see also RE 90221); HETG (rape seed oil) ²⁾ ; HEPG (polyglycols) ³⁾ ; HEES (synthetic esters) ³⁾ ; HVLP ⁴⁾ ; HFC ⁵⁾ ; other hydraulic fluids upon request				
Hydraulic fluid temperature range	°C	-25 to +80 (for NBR seals) -20 to +80 (for FKM seals) -40 to +80 (low-temperature seals)				
Viscosity range	mm ² /s	10 to 800				
Maximum permitted degree of contamination of the hydraulic fluid - cleanliness class according to ISO 4406 (c)		Class 20/18/15 ⁶⁾				
Load cycles		≥ 5 million				

1) Direction of rotation:
 – Clockwise → Set pressure increase
 – Anticlockwise → Set pressure decrease

2) Suitable for NBR and FKM seals

3) Suitable only for FKM seals

4) Suitable for low-temperature seals

5) Suitable only for NBR seals

6) The cleanliness classes specified for the components must be adhered to in hydraulic systems. Effective filtration prevents faults and at the same time increases the service life of the components.

For the selection of the filters see www.boschrexroth.com/filter.

Technical data (For applications outside these parameters, please consult us!)

electric

Electrical connection / mating connector	K14	EN 175301-803, 3-pole + PE	
	K35	IEC 61076-2-101, M12 x 1, A-coding, 4-pole	
Protection class according to EN 60529	K14	IP 65 with mating connector mounted and locked	
	K35	IP 67 with mating connector mounted and locked	
Maximum switching frequency	1/h	7200	
Switching accuracy (repetition accuracy)		< ±1 % of the set pressure	
Switches		According to VDE 0630-1/DIN EN 61058-1	
Transition resistance	mΩ	< 50	
Insulation coordination		Overvoltage category 3	
Contamination		Degree of contamination 3	
Bounce time	ON	ms	< 5
	OFF	ms	< 5
Minimum current	mA	1.0 with 24 V DC	
Maximum current	A	0.5 with 50 V DC, inductive 0.2 with 125 V DC, inductive 0.1 with 250 V DC, inductive 2.0 with 250 V AC	

Switching power

Switching cycles	Voltage <i>U</i> in V	Ohmic load max. in A	Inductive load max. in A
2 million	250, AC	2 A for 2 million switching cycles	0.5 A, cos. φ = 0.6 for 2 million switching cycles
2 million	24, DC	2 A for 2 million switching cycles	0.5 A for 2 million switching cycles
5 million	24, DC	5.0 mA for 5 million switching cycles	–

Archivierung: 08/2012

Characteristic curves Switching pressure differential

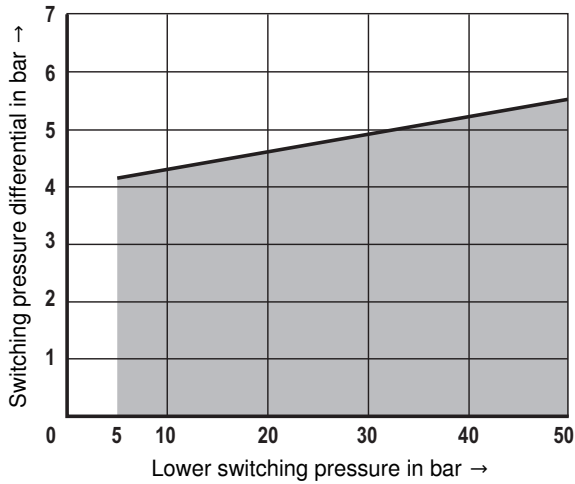
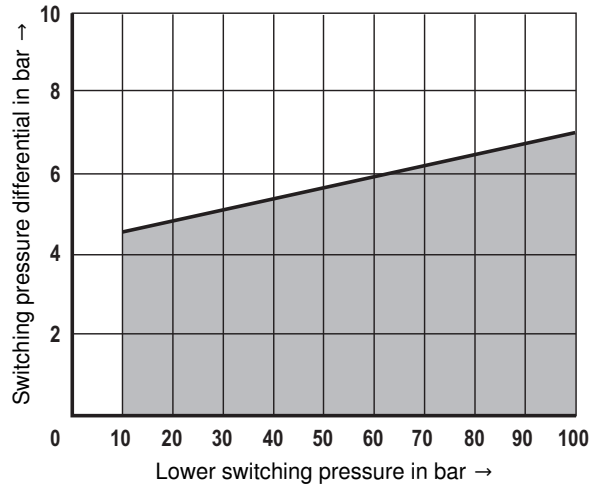
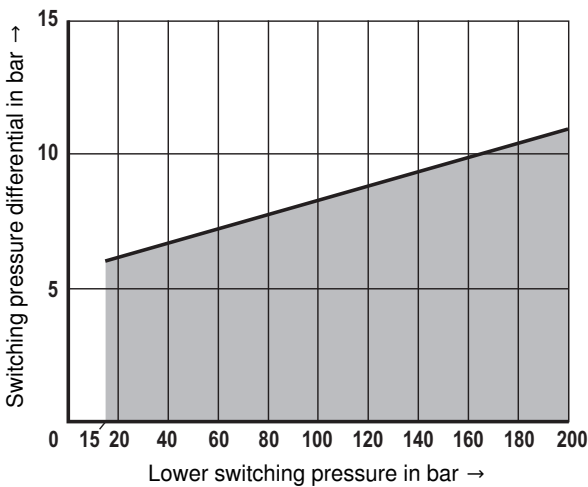
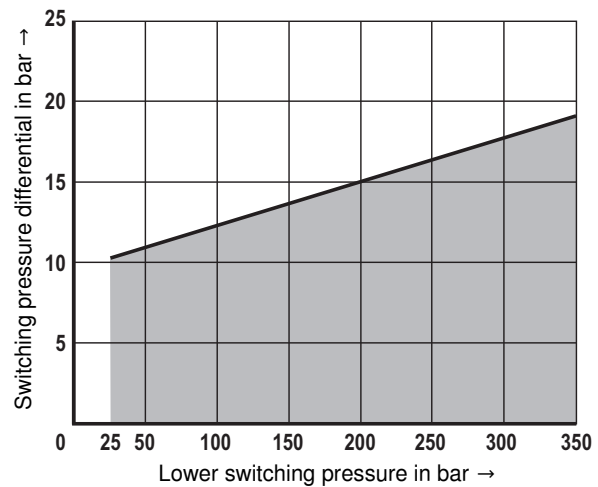
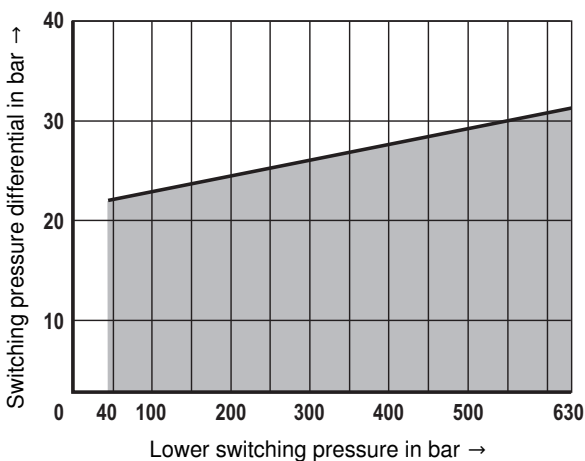
Pressure rating 50

Pressure rating 100

Pressure rating 200

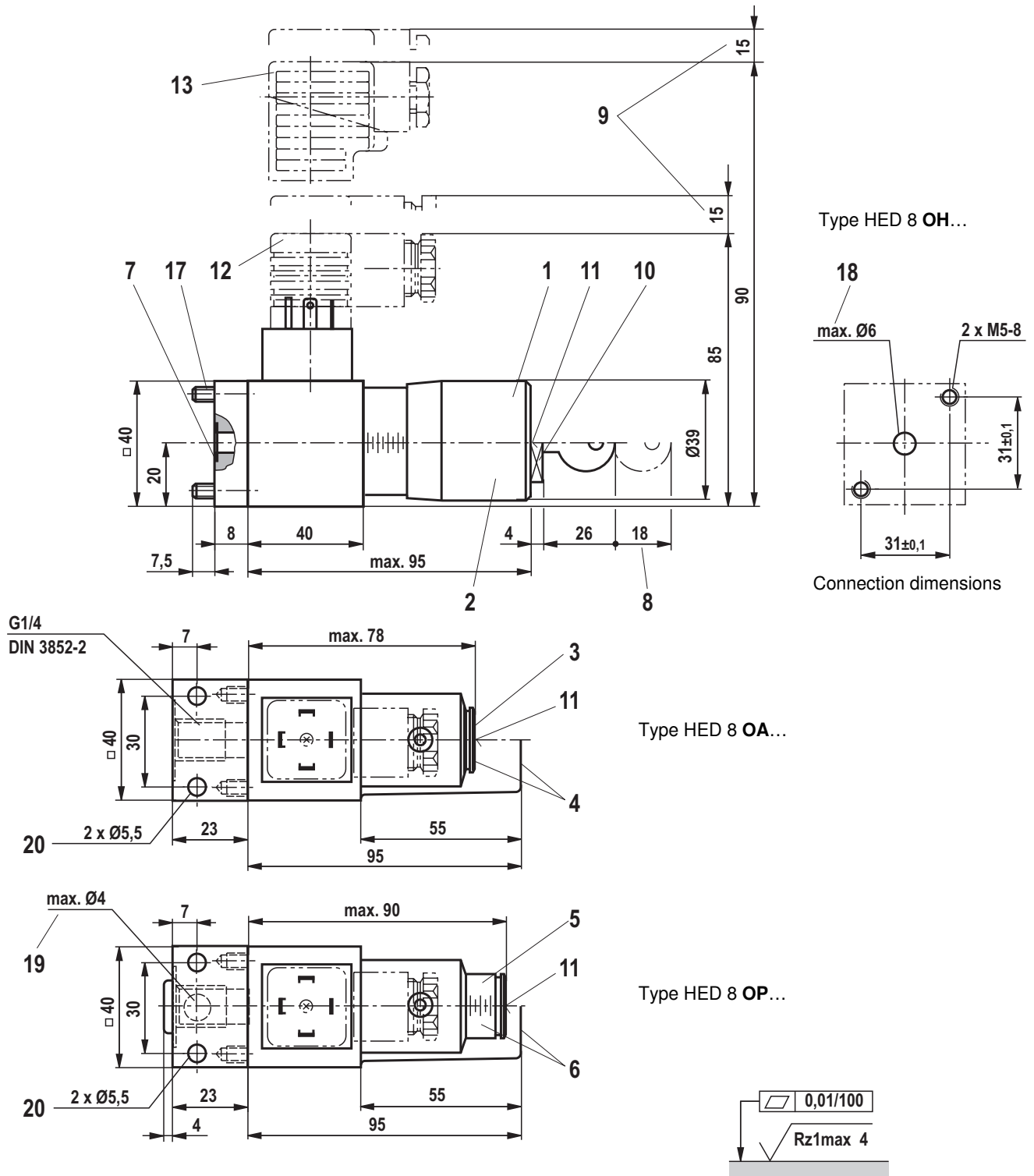
Pressure rating 350

Pressure rating 630

Notice:

The switching pressure differential may increase within the course of the service life due to the deterioration of the oil quality and the number of load cycles.

Unit dimensions: Type HED 8 ...K14 (dimensions in mm)



Item explanations see page 9

Required surface quality of the device contact surface (with version "OH" and "OP")

Unit dimensions: Type HED 8 ...K35 (dimensions in mm)

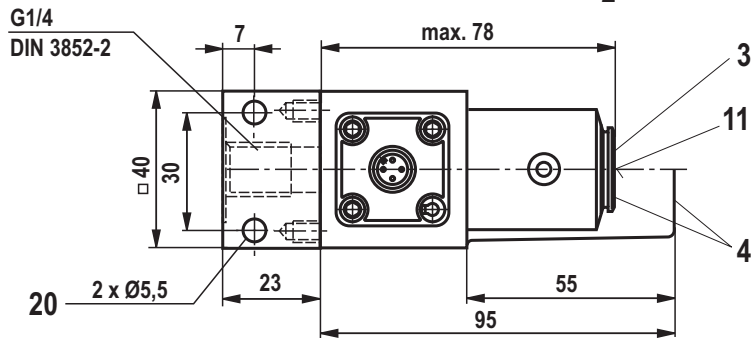
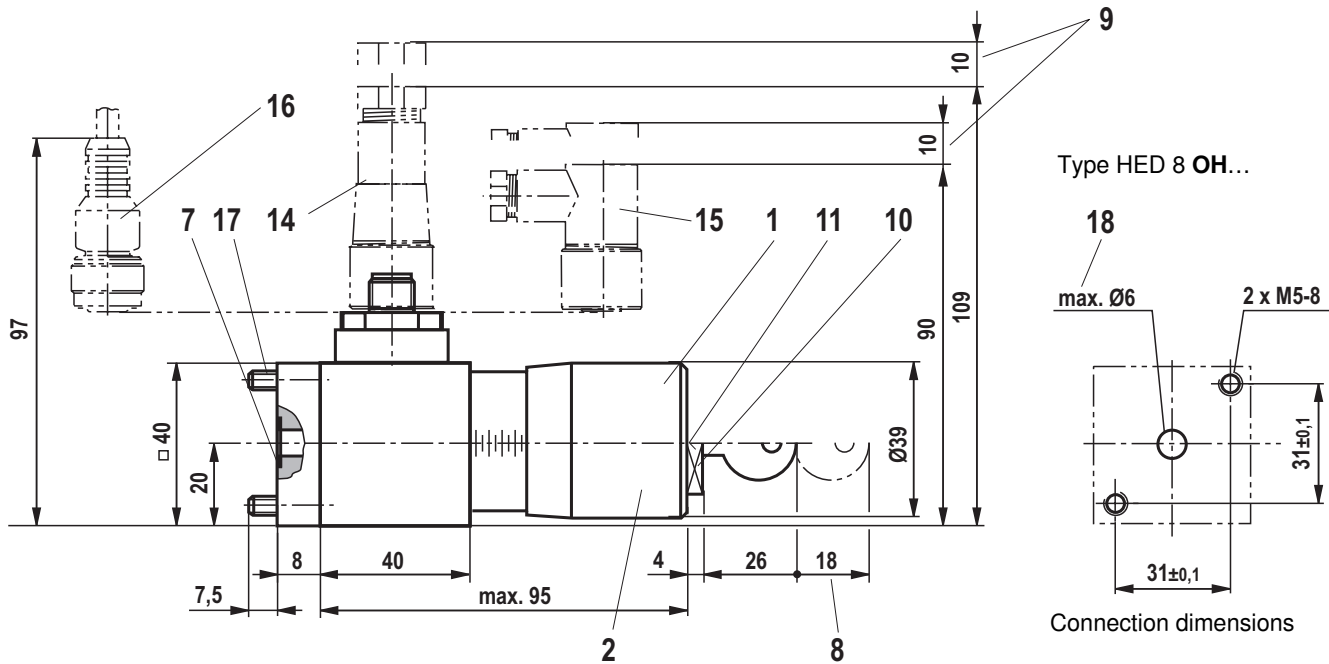

Type HED 8 OA...

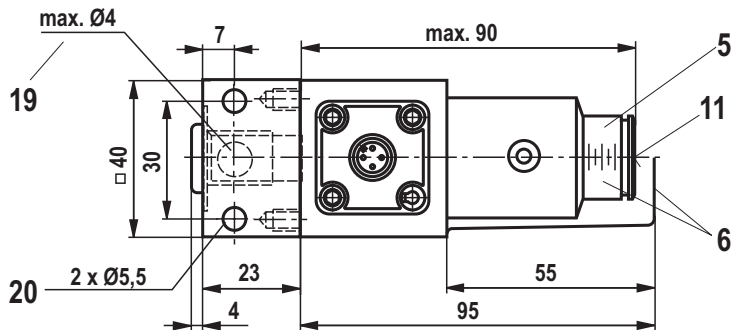

Type HED 8 OP...

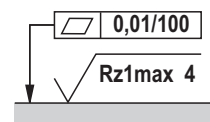

Required surface quality of the device contact surface (with version "OH" and "OP")

Item explanations see page 9

Unit dimensions

Item explanations:

- | | |
|--|---|
| <ul style="list-style-type: none"> 1 Adjustment type "KW" 2 Adjustment type "KS" 3 Adjustment type "-" 4 Adjustment type "S" 5 Adjustment type "A" 6 Adjustment type "AS" 7 Seal ring 8 Space required to remove the key 9 Space required to remove the mating connector 10 Hexagon SW27 (with adjustment type "KS") 11 Internal hexagon SW10 12 Mating connector without circuitry for connection "K14" (separate order, see page 16) 13 Mating connector with circuitry for connection "K14" (separate order, see page 16) 14 Mating connector for connection "K35" (separate order see page 16) 15 Mating connector suitable for "K35", angled (separate order see page 16) 16 Mating connector for connection "K35", with cable (separate order see page 16) | <ul style="list-style-type: none"> 17 Valve mounting screws
for type HED 8 OH... (separate order)
2 hexagon socket head cap screws
ISO 4762 - M5 x 55 - 10.9-fIZn-240h-L
Friction coefficient $\mu_{\text{total}} = 0.09$ to 0.14,
tightening torque $M_A = 6^{+0.5}$ Nm,
material no. R913000261 18 Maximum diameter of the connection bore of the counterpart (type HED 8 OH...) 19 Maximum diameter of the connection bore of the counterpart (type HED 8 OP...) 20 Valve mounting screws
for type HED 8 OA... and ...OP... (separate order)
2 hexagon socket head cap screws
ISO 4762 - M5 x 50 - 10.9-fIZn-240h-L
Friction coefficient $\mu_{\text{total}} = 0.09$ to 0.14,
tightening torque $M_A = 7^{+0.5}$ Nm,
material no. R913000064 |
|--|---|

Archivierung: 08/2012

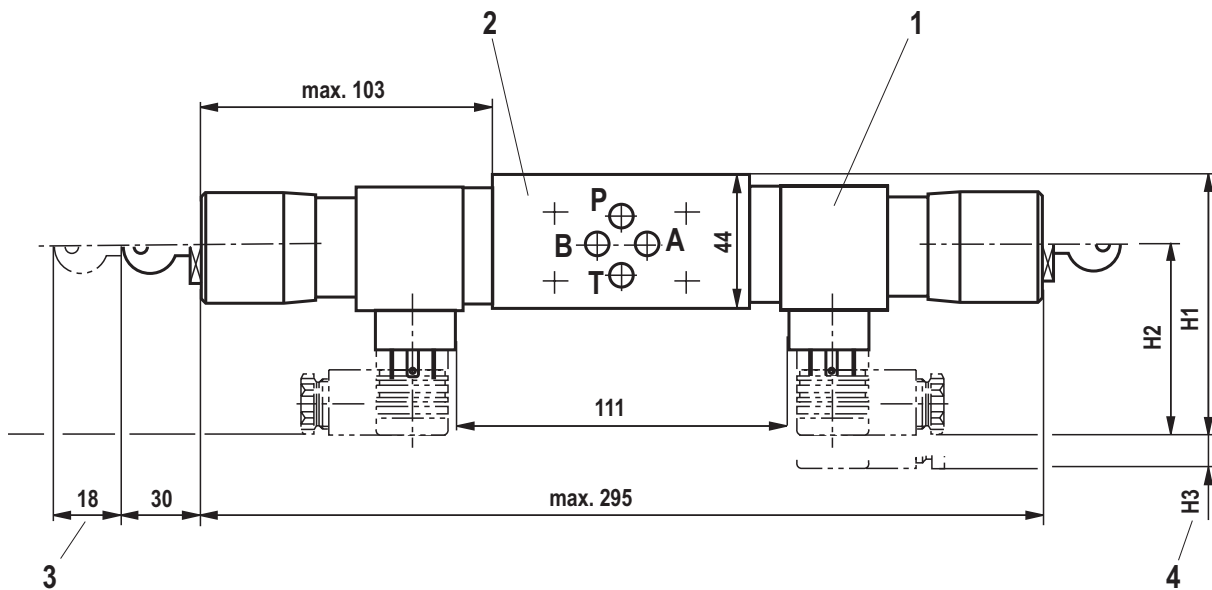
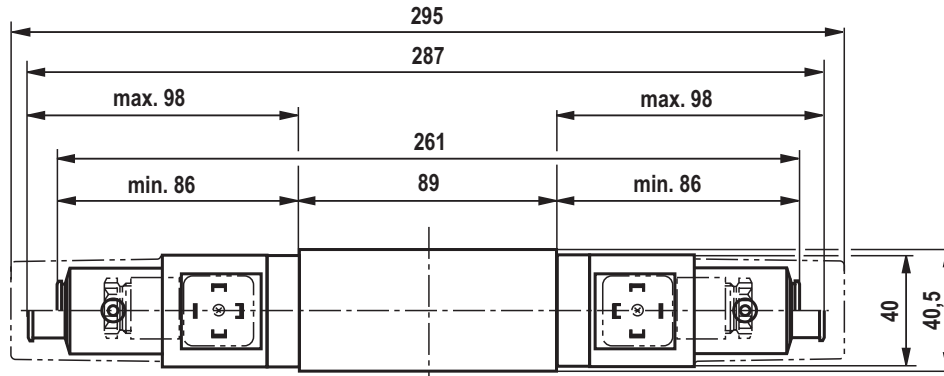
Installation information: Type HED 8 OH... in vertical stacking size 6 (dimensions in mm)

- 1 Pressure switch HED 8 OH... for use in stacking assemblies (can be assembled staggered by $4 \times 90^\circ$)
The mounting option of the pressure switch depends on the set-up of the next stacking assembly subplate.
- 2 Sandwich plate type HSZ 06A... for use of the pressure switch as stacking element (see page 12)
- 3 Space required to remove the key
- 4 Space required to remove the mating connector

Mating connector	H1	H2	H3
"K14" connection without circuitry	87	65	15
"K14" connection with circuitry	92	70	15
"K35" connection, angled	92	70	10
"K35" connection, straight	111	89	10

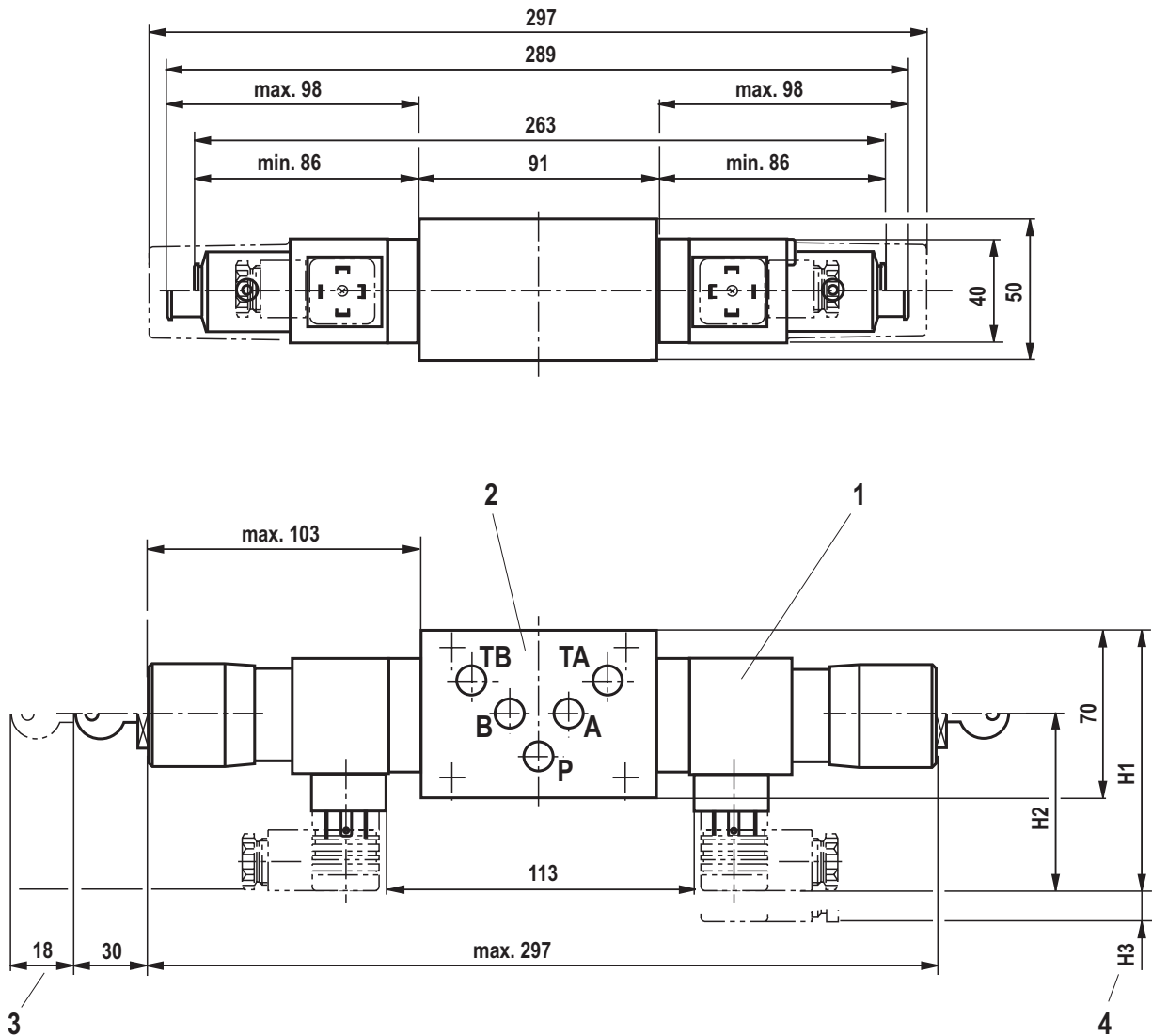
Installation information: Type HED 8 OH... in vertical stacking size 10 (dimensions in mm)

- 1 Pressure switch HED 8 OH... for use in stacking assemblies (can be assembled staggered by 4 x 90°)
The mounting option of the pressure switch depends on the set-up of the next stacking assembly subplate.
- 2 Sandwich plate type HSZ 10A... for use of the pressure switch as stacking element (see page 14)
- 3 Space required to remove the key
- 4 Space required to remove the mating connector

Mating connector	H1	H2	H3
"K14" connection without circuitry	100	65	15
"K14" connection with circuitry	105	70	15
"K35" connection, angled	105	70	10
"K35" connection, straight	124	89	10

Ordering code: Sandwich plate size 6 (separate order)

HSZ	06	A	-3X/	00	*
Sandwich plate			Further details in the plain text		
Size 6		= 06			
Porting pattern according to ISO 4401-03-02-0-05		= A			
Variant no. (see below)		= 6...			
Component series 30 to 39		= 3X			
(30 to 39: Unchanged installation and connection dimensions)					
			M = V = MT =	Seal material NBR seals FKM seals Low-temperature seals (max. 315 bar) (other seals upon request) Notice: Observe compatibility of seals with the hydraulic fluids used.	

Symbols, variant no.: Sandwich plate size 6 (① = component side, ② = plate side)

		Pressure switch effective in channel ...		
Variant number	Plate height in mm / weight in kg			
	40.5 / 0.8	608	609	601
	120 / 3	627	628	620
Variant number	40.5 / 0.8			
	120 / 3	602	603	604
		621	622	623
Variant number	40.5 / 0.8			
	120 / 3	605	606	607
		624	625	626
Variant number	40.5 / 0.8			
	120 / 3	610	611	612
		629	630	631
Variant number	40.5 / 0.8			
	-	613		

Archivierung: 08/2012

Unit dimensions: Sandwich plate size 6 (dimensions in mm)

Type HED 8 OH... as vertical stacking element (up to 350 bar)

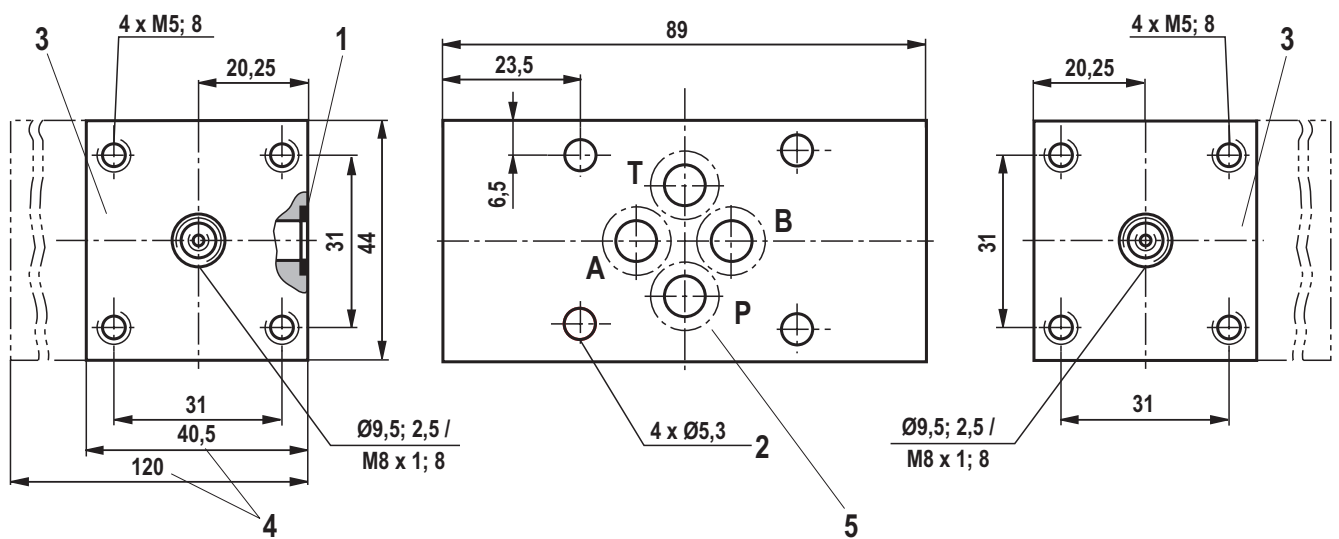

- 1 Seal ring
- 2 Through hole for valve mounting
- 3 Screw-on surface for pressure switch
- 4 Plate height 40.5 mm or 120 mm, optional
- 5 Porting pattern according to ISO 4401-03-02-0-05

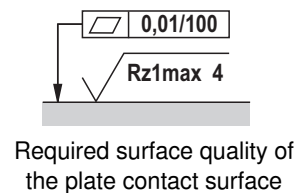

Ordering code: Sandwich plate size 10 (separate order)

HSZ	10	A	-3X/	00	*
-----	----	---	------	----	---

Sandwich plate

Size 10 = 10

Porting pattern according to ISO 4401-05-04-0-05 = A

Variant no. (see below) = 6...

Component series 30 to 39 (30 to 39: Unchanged installation and connection dimensions) = 3X

Further details in the plain text

M = V = MT =	Seal material NBR seals FKM seals Low-temperature seals (max. 315 bar) Notice: Observe compatibility of seals with the hydraulic fluids used.
---	--

Symbols, variant no.: Sandwich plate size 10 (① = component side, ② = plate side)

		Pressure switch effective in channel ...		
	Weight in kg			
Variant number	2	601	602	603
Variant number	2	604	605	606
Variant number	2	607	608	609
Variant number	2	610	611	612

Archivierung: 08/2012

Unit dimensions: Sandwich plate size 10 (dimensions in mm)

Type HED 8 OH... as vertical stacking element (up to 350 bar)

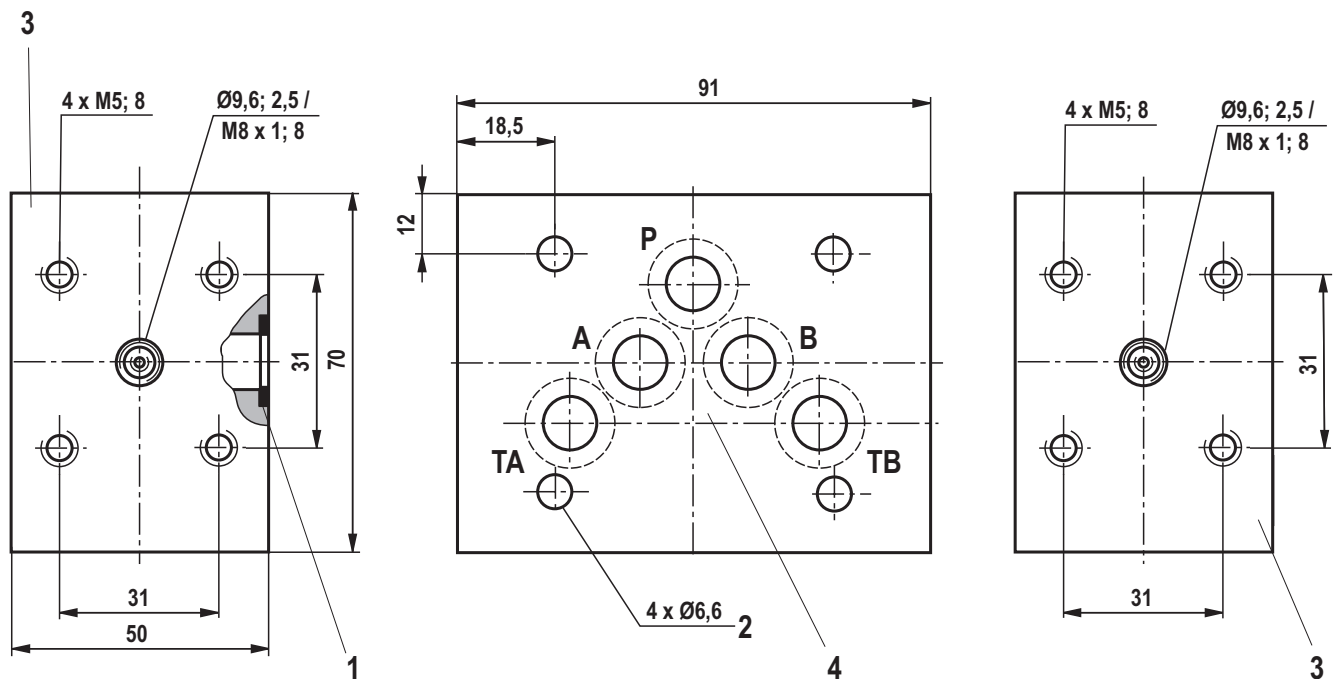

- 1 Seal ring
- 2 Through hole for valve mounting
- 3 Screw-on surface for pressure switch
- 4 Porting pattern according to ISO 4401-05-04-0-05

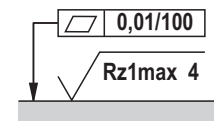

Required surface quality of the plate contact surface

Archivierung: 08/2012

Electrical connection

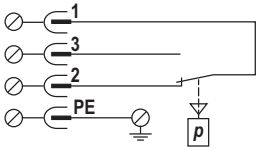
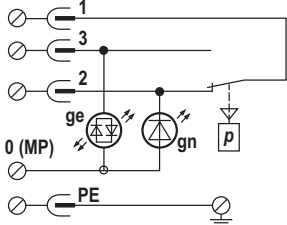
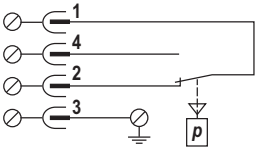
"K14" without indicator light	"K14" with indicator light	"K35"
		
Switching function Terminals 1-2: Contact opens in case of pressure increase Terminals 1-3: Contact closes in case of pressure increase		Switching function Terminals 1-2: Contact opens in case of pressure increase Terminals 1-4: Contact closes in case of pressure increase

Mating connectors
For connection "K14"

For details and more mating connectors see data sheet 08006						
	Material no.					
	without circuitry 240 V, -40...+125 °C	with circuitry (indicator light) AC/DC, -20...+60 °C				
Color black	R901017012	R901017030	R901017048	R901017032	R901017035	R901017037

For connection "K35"

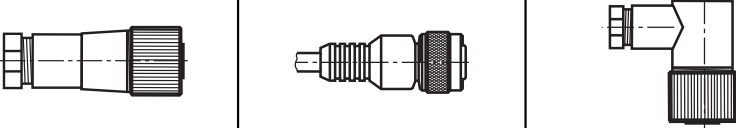
For details and more mating connectors see data sheet 08006			
	Material no.		
	4-pole, M12 x 1 with screw connection, -40...+85 °C	4-pole, M12 x 1 with PUR cable, 3 m long, -25...+85 °C	4-pole, M12 x 1 with screw connection, angled, -40...+85 °C
Color black	R900031155	R900064381	R900082899

Bosch Rexroth AG
 Hydraulics
 Zum Eisengießer 1
 97816 Lohr am Main, Germany
 Phone +49 (0) 93 52 / 18-0
 documentation@boschrexroth.de
 www.boschrexroth.de

© This document, as well as the data, specifications and other information set forth in it, are the exclusive property of Bosch Rexroth AG. It may not be reproduced or given to third parties without its consent. The data specified above only serve to describe the product. No statements concerning a certain condition or suitability for a certain application can be derived from our information. The information given does not release the user from the obligation of own judgment and verification. It must be remembered that our products are subject to a natural process of wear and aging.