

## Variable Vane Pump, Direct Controlled PV7...A Series 1X / 2X

**RE 10522**

Issue: 01.2013

Replaces: 08.2008



- ▶ Sizes 10 to 25
- ▶ Maximum pressure 100 bar
- ▶ Displacement volume 10 to 25 cm<sup>3</sup>

**Features**

- ▶ Very short control times
- ▶ Low noise
- ▶ Mounting and connection dimensions to VDMA 24560/1 and ISO 3019-2
- ▶ Good efficiency
- ▶ Long service life
- ▶ Variable displacement volumes

**Contents**

Ordering code	2
Functional description	3
Technical data	4
Dynamic characteristics measuring layout	5
Characteristics PV7-../06-10	6
Characteristics PV7-../06-14	7
Characteristics PV7-../20-20	8
Characteristics PV7-../20-25	9
Dimensions PV7-../06	10
Dimensions PV7-../20	11
Engineering guidelines	12
Installation instructions	13
Commissioning instructions	14

**2 PV7...A Series 1X / 2X | Variable vane pump, direct controlled**  
 Ordering code

**Ordering code**

01	02	03	04	05	06	07	08	09	10	11
PV7	-	/	R	A	01	M	A	-		

**Type**

01	Vane pump, direct controlled, maximum operating pressure 100 bar	<b>PV7</b>
----	--	------------

**Series of devices**

02	Frame size 06, device series 10 to 19, unchanged mounting and connection dimensions	<b>1X</b>
	Frame size 20, device series 20 to 29, unchanged mounting and connection dimensions	<b>2X</b>

**Frame size BG**
**Size NG [cm<sup>3</sup>]**

03	BG 06	10	<b>06-10</b>
		14	<b>06-14</b>
	BG 20	20	<b>20-20</b>
		25	<b>20-25</b>

**Direction of rotation**

04	Viewed on drive shaft, right	<b>R</b>
----	------------------------------	----------

**Drive shaft**

05	Parallel keyed shaft	<b>A</b>
----	----------------------	----------

**Pipe connections**

06	Suction and pressure port with pipe thread according to DIN EN ISO 228-1	<b>01</b>
----	--	-----------

**Seals**

07	NBR seals, suitable for HLP mineral oil according to DIN 51524	<b>M</b>
----	--	----------

**Control unit**

08	Direct controlled	<b>A</b>
----	-------------------	----------

**Control device**

09	Adjustment screw (Standard)	<b>0</b>
	Controller with lock	<b>3</b>

**Zero stroke pressure range<sup>1)</sup>**

10	V7/06-10	25 to 50 bar	<b>05</b>
		50 to 100 bar	<b>10</b>
	V7/06-14	15 to 40 bar	<b>04</b>
		40 to 70 bar	<b>07</b>
	V7/20	25 to 50 bar	<b>05</b>
		50 to 100 bar	<b>10</b>

11	Further details in clear text	
----	-------------------------------	--

**Preferred type (available on short notice)**

Type	Material number
PV7-1X/06-10RA01MA0-05	R900561857
PV7-1X/06-10RA01MA0-10	R900563233
PV7-1X/06-14RA01MA0-04	R900919235
PV7-1X/06-14RA01MA0-07	R900919237
PV7-2X/20-20RA01MA0-05	R900950952
PV7-2X/20-20RA01MA0-10	R900950953
PV7-2X/20-25RA01MA0-05	R900950954
PV7-2X/20-25RA01MA0-10	R900950955

**Pump with customer-specific settings:**

- ▶ PV7-1X/06-14RA01MA0-07-P50,  $p_{\text{zero stroke}} = 50$  bar
  - ▶ PV7-1X/06-14RA01MA0-07-Q20,  $q_{V \text{ max}} = 20$  L/min
- The pump will be set to the required values. The optimum operating noise will be set at the required zero stroke pressure. Without any clear text setting information the flow and the zero stroke pressure will be set to the relevant maximum values.

<sup>1)</sup> As delivered the zero stroke pressure is set to the smallest value!

## Functional description

Hydraulic pumps, type PV7...A are direct controlled vane pumps with variable displacement.

The basically comprise of the housing (1), cover (2), rotor (3), vanes (4), stator ring (5), pressure spring (6), adjustment screw (7) and control plate (8).

For limiting the maximum flow, the pump is fitted with an adjustment screw (9).

The driven rotor (3) rotates within the stator ring (5). The vanes (4) which are guided in the rotor (3) are pressed against the inner running surface of the stator ring (5) by centrifugal force.

### Suction and displacement process

The chambers (10) which are required for the transport of the hydraulic fluid are formed by the vanes (4), the rotor (3), the stator ring (5), the control plate (8) and the cover plate (2).

The chamber volume increases as the rotor (3) rotates and the chambers are filled with hydraulic fluid via the suction channel (S). When the largest chamber volume is reached, the chambers (10) are separated from the suction side. As the rotor (3) continues to rotate the connection to the pressure side is opened, the chambers decrease in size and force the hydraulic fluid into the system via the pressure port (P).

### Pressure control

The stator ring (5) is held in its initial excentric position by spring (6). The maximum operating pressure required in the system is set at the adjustment screw (7) via the spring (6).

The pressure which builds up due to the work resistance acts on the pressure side of the inner running surface of the stator ring (5), against the force of the spring (6). When the relevant pressure is reached, which is determined by the set spring force, the stator ring (5) is moved out of its excentric position in the direction of the zero position. The flow adjusts itself to the value which is being demanded at that time. When the maximum pressure, which has been set at the spring (6), has been reached then the pump regulates the flow back to virtually zero. The operating pressure is maintained and only the case drain is replaced. Losses and heating of the hydraulic fluid is thereby minimized.

#### ▼ PV7-1X/06...A...

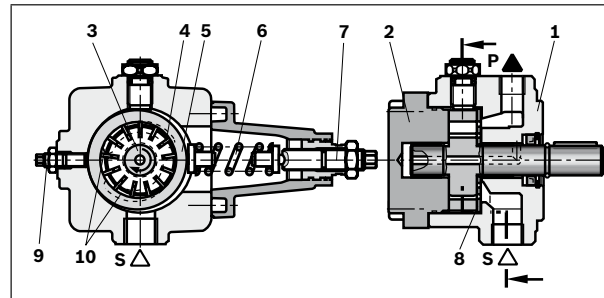

#### ▼ PV7-2X/20...A...

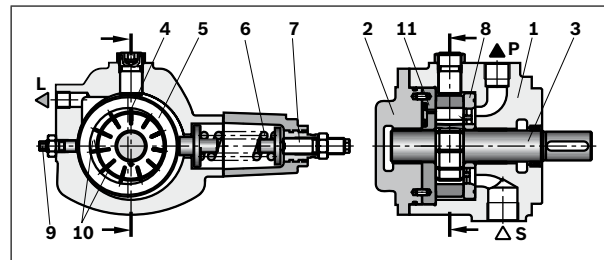

#### ▼ Symbol

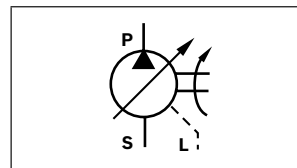

#### 4 PV7...A Series 1X / 2X | Variable vane pump, direct controlled Technical data

### Technical data

Frame size			BS	06	06	20	20
Displacement		$V$	cm <sup>3</sup>	10	14	20	25
Speed		$n$	rpm	900 to 1800	900 to 1800	900 to 1800	900 to 1800
Torque maximum		$T$	Nm	50	50	110	110
Operating pressure, absolute	Inlet	$p_{\min-\max}$	bar	0.8 to 2.5	0.8 to 2.5	0.8 to 2.5	0.8 to 2.5
	Outlet	$p_{\max}$	bar	100	70	100	100
	Case drain outlet	$p_{\max}$	bar	2	2	2	2
Case drain flow at zero stroke (at outlet operating pressure= $p_{\text{zero stroke max}}$ )		$q_v$	l/min	1.7	1.7	2.0	2.4
Shaft loading		Radial and axial forces are not permissible					
Flow maximum <sup>1)</sup> (at $n = 1450$ rpm $p = 10$ bar; $v = 41$ mm <sup>2</sup> /s)		$q_v$	l/min	14.5	20	29	36
Weight		$m$	kg	6.3	6.3	11.4	11.4
Flow change (at one revolution of the adjustment screw and $n = 1450$ rpm)		$q_v$	l/min	7.5	7.5	14	14
Hydraulic fluid		Mineral oil HLP according to DIN 51524 part 2 Please take the specifications stated in data sheet 90220 into account! Further fluids on request.					
Hydraulic fluid temperature range		$\theta$	°C	-10 to +70, take the permissible viscosity range into account!			
Viscosity range		$v$	mm <sup>2</sup> /s	16 to 160 at operating temperature maximum 800 at pump start with an operating flow maximum 200 at pump start in zero flow condition			
Maximum permissible degree of contamination of the hydraulic fluid, cleanliness level according to ISO 4406 (c)		Class 19/16/13 <sup>2)</sup>					
Mounting style		Flange mounting					

#### Note

Please contact us if the unit is to be used outside the specified values!

- 1) Flow deviations (due to manufacturing tolerances) of a max. of + 6 % is possible
- 2) Cleanliness levels specified for the components must be maintained in the hydraulic systems. Effective filtration prevents faults from occurring and at the same time increases the component service life.  
For the selection of filters see data sheets 50070, 50076, 50081, 50086, 50087 and 50088.

## Dynamic characteristics measuring layout

The control times are valid for the measurement build-up as shown. For other set-ups and line lengths the control times will change.

### ▼ Schematic

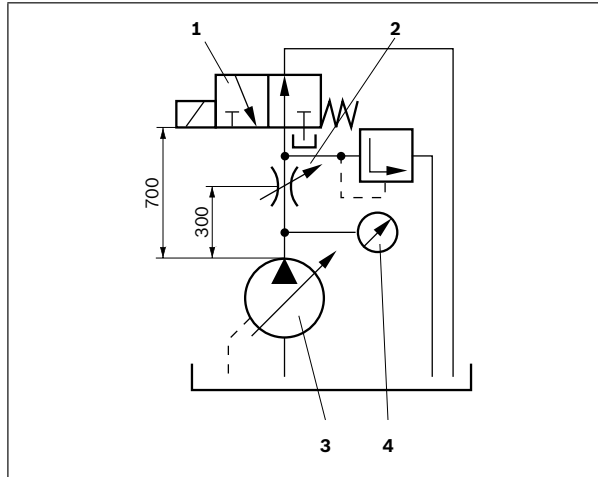

- 1 Directional valve (switching time 30 ms)
- 2 Throttle for setting the pressure during displacement
- 3 Hydraulic pump
- 4 Pressure measuring point

### Control down

$q_v$  displacement →  $q_v$  zero stroke

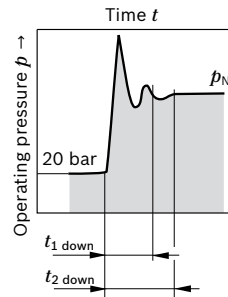

Pump type	Pressure		Control times (median values)	
	$p_N$ [bar]	$p_{\max}^{1)}$	$t_{1 \text{ down}}$	$t_{2 \text{ down}}$
06-10...10	100	150	85	90
06-10...05	50	130	70	110
06-14...07	70	130	80	100
06-14...04	40	100	65	90
20-20...10	100	170	80	125
20-25...10	100	170	80	125
20-25...05	50	120	60	85

### Control up

$q_v$  zero stroke →  $q_v$  displacement

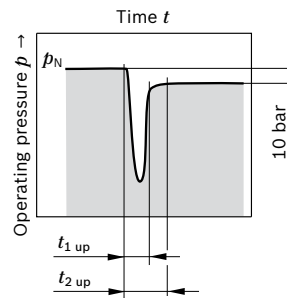

Pump type	Pressure	Control times (median values)	
	$p_N$ [bar]	$t_{1 \text{ up}}$	$t_{2 \text{ up}}$
06-10...10	100	35	60
06-10...05	50	20	30
06-14...07	70	30	50
06-14...04	40	20	35
20-20...10	100	25	45
20-25...10	100	25	45
20-25...05	50	20	40

1) Permissible pressure spikes

6 **PV7...A Series 1X / 2X** | Variable vane pump, direct controlled  
 Characteristics PV7-../06-10

**Characteristics PV7-../06-10**

▼ PV7-../06-10....A0-05...

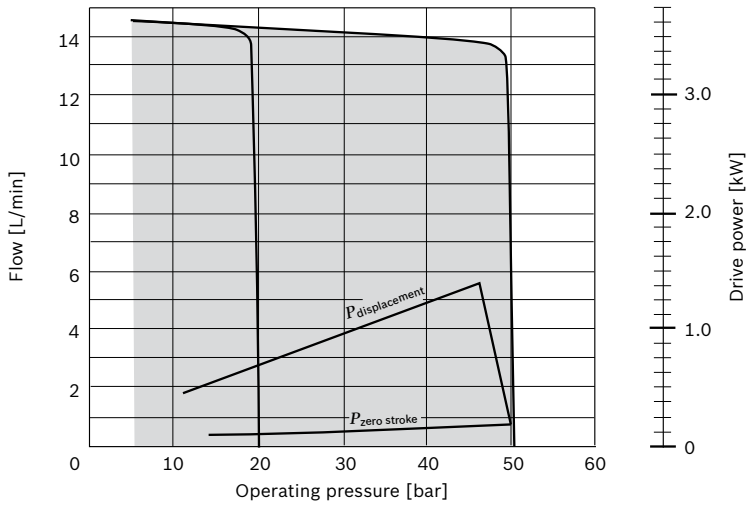

▼ PV7-../06-10....A0-10...

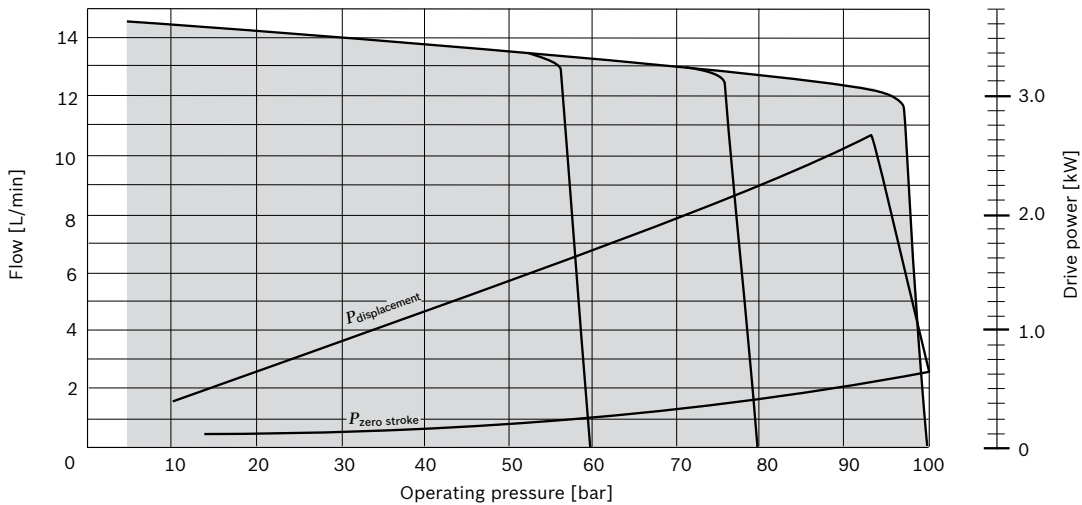

▼ Sound pressure level

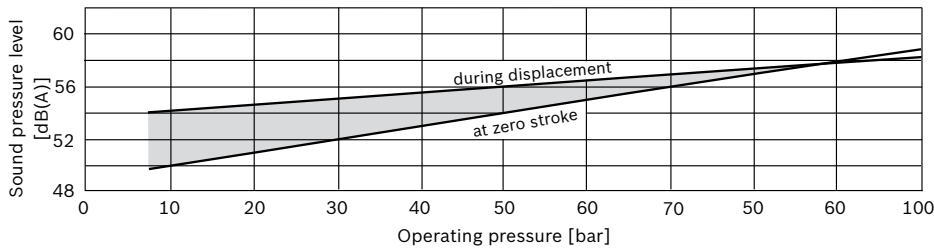

**Note**

Characteristics measured at  $n = 1450$  rpm;  $v = 41$  mm<sup>2</sup>/s;  $\theta = 50$  °C

Sound pressure level measured in acoustic room according to DIN 45635, page 26; distance: microphone – pump = 1 m

**Characteristics PV7-../06-14**

## ▼ PV7-../06-14....A0-04...

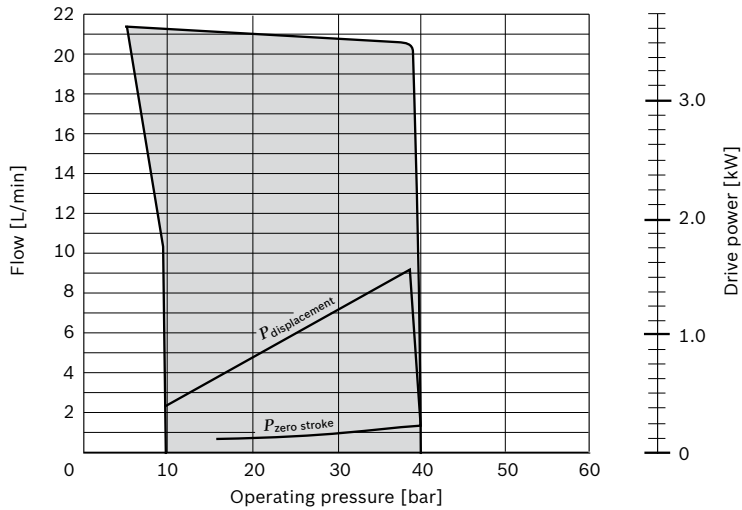

## ▼ PV7-../06-14....A0-07...

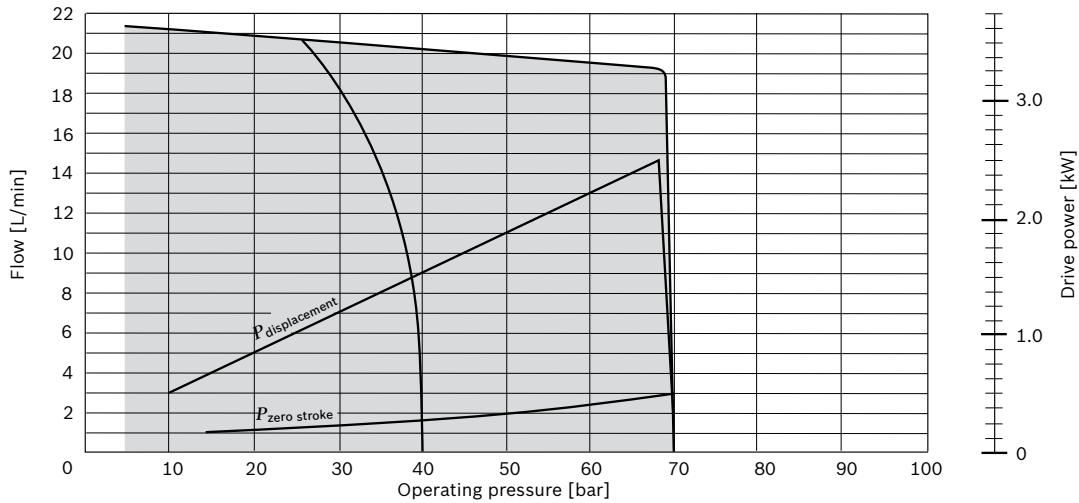

## ▼ Sound pressure level

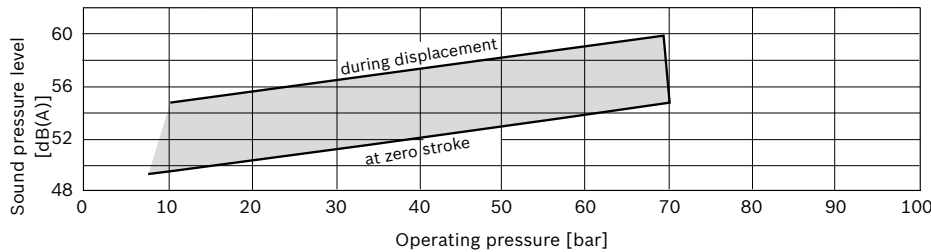
**Note**

 Characteristics measured at  $n = 1450 \text{ rpm}$  ;  $v = 41 \text{ mm}^2/\text{s}$  ;  $\theta = 50 \text{ }^\circ\text{C}$ 

Sound pressure level measured in acoustic room according to DIN 45635, page 26; distance: microphone – pump = 1 m

8 **PV7...A Series 1X / 2X** | Variable vane pump, direct controlled  
 Characteristics PV7-../20-20

### Characteristics PV7-../20-20

#### ▼ PV7-../20-20....A0-05...

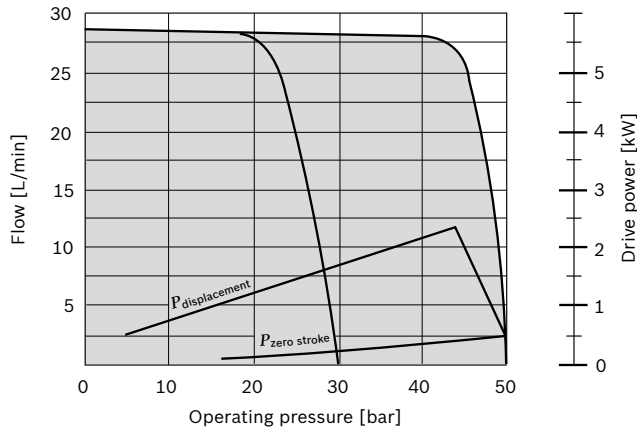

#### ▼ PV7-../20-20....A0-10...

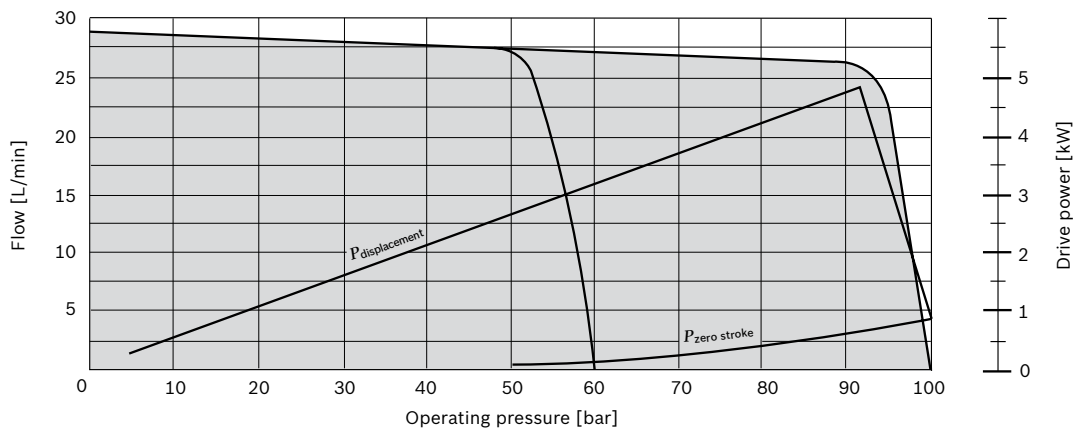

#### ▼ Sound pressure level

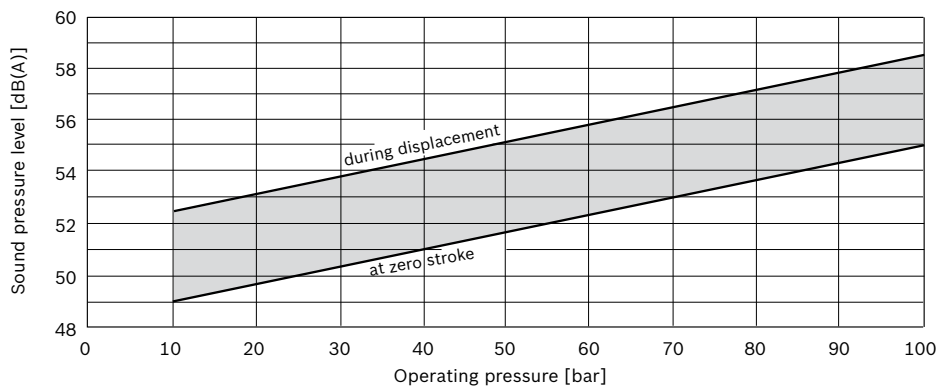

#### Note

Characteristics measured at  $n = 1450 \text{ rpm}$  ;  $v = 41 \text{ mm}^2/\text{s}$  ;  $\theta = 50 \text{ }^\circ\text{C}$

Sound pressure level measured in acoustic room according to DIN 45635, page 26; distance: microphone – pump = 1 m

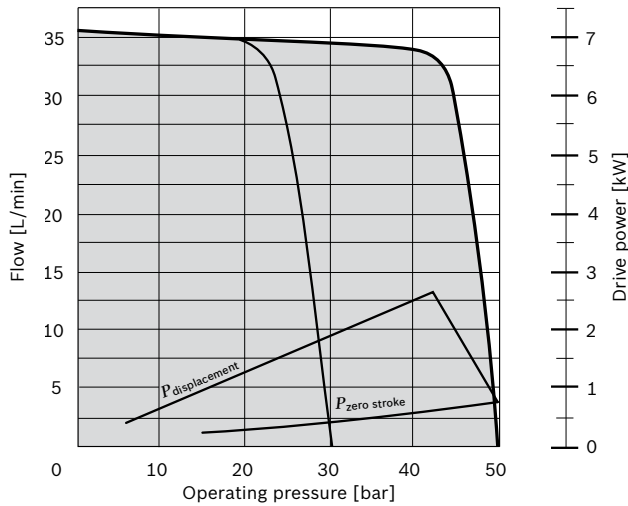
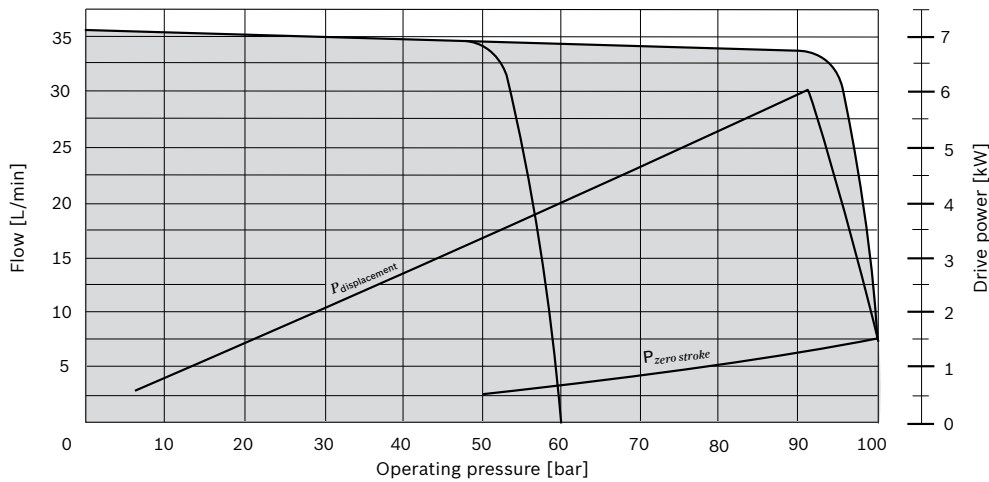
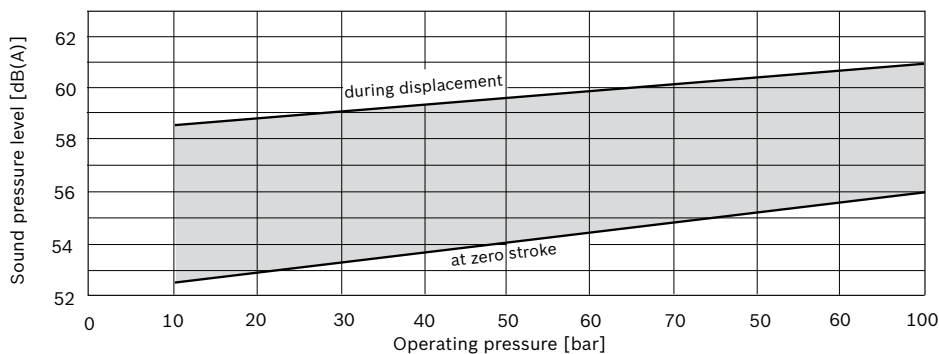

**Characteristics PV7-../20-25**

 ▼ **V7-../20-25....A0-05...**

 ▼ **V7-../20-25....A0-10...**

 ▼ **Sound pressure level**

**Note**

 Characteristics measured at  $n = 1450 \text{ rpm}$  ;  $v = 41 \text{ mm}^2/\text{s}$ ;  $\theta = 50 \text{ }^\circ\text{C}$ 

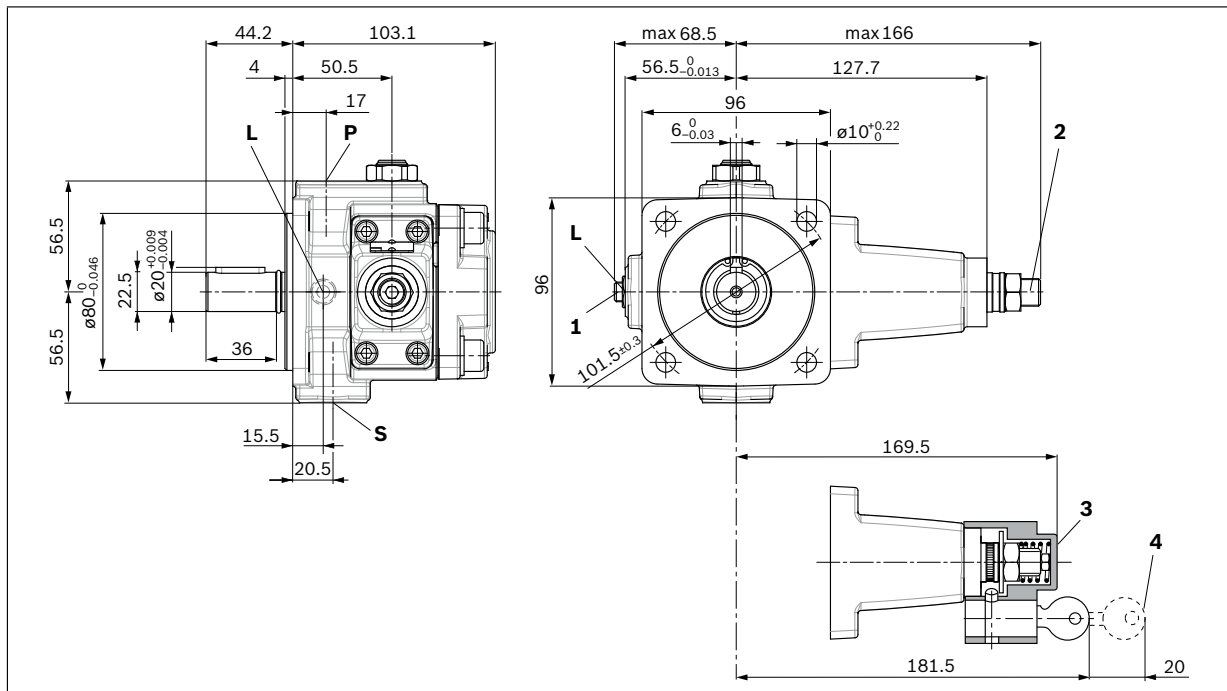
Sound pressure level measured in acoustic room according to DIN 45635, page 26; distance: microphone – pump = 1 m

 RE 10522/01.2013, **Bosch Rexroth AG**

Archivierung 10/2016

**Dimensions PV7-../06**

- 1 Flow adjustment
- 2 Pressure adjustment with adjustment screw (Standard), ordering code ...0...
- 3 Lock (optional), ordering code ...3...
- 4 Space required to remove key

**Ports**

Designation	Size
<b>S</b> Suction port	G1/2
<b>P</b> Pressure port	G3/8
<b>L</b> Case drain port	G1/4

**Notes for adjustments**

- ▶ Flow adjustment (**1**)
  - at clockwise rotation, decrease of flow
  - at counter clockwise rotation, increase of flow
- ▶ Pressure adjustment (**2**)
  - at clockwise rotation, increase of operating pressure
  - at counter clockwise rotation, decrease of operating pressure

Dimensions [mm]

 Variable vane pump, direct controlled | **PV7...A Series 1X / 2X** 11  
 Dimensions PV7-../20

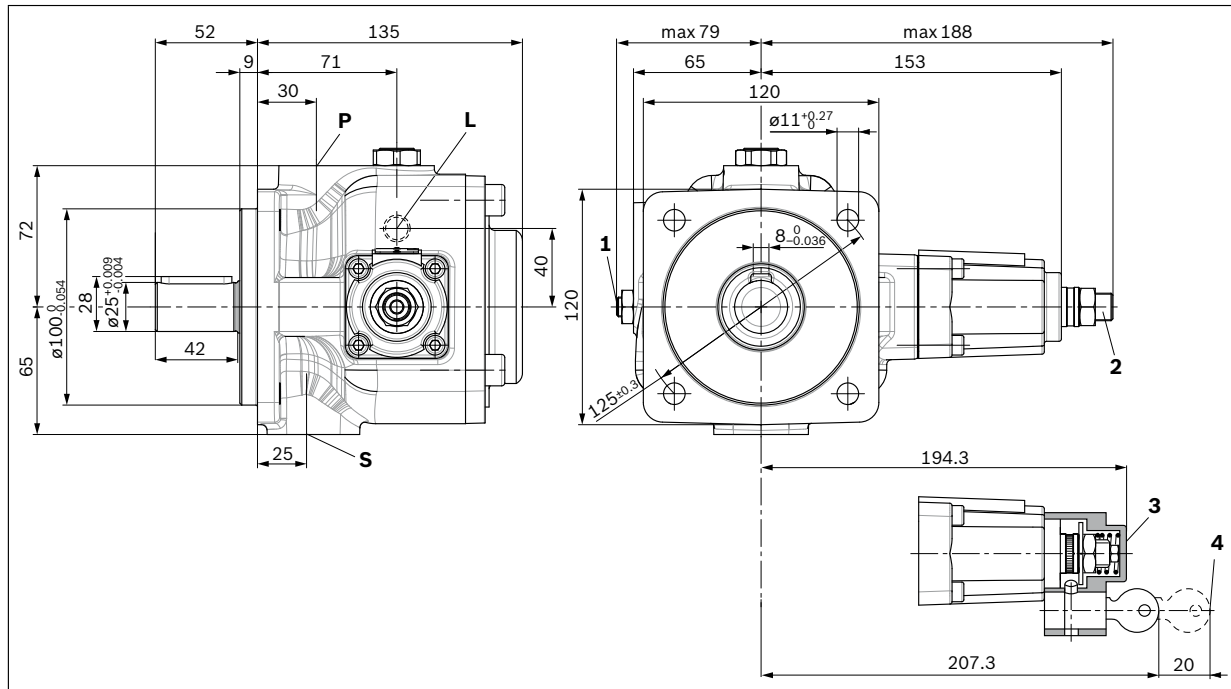
**Dimensions PV7-../20**

- 1 Flow adjustment
- 2 Pressure adjustment with adjustment screw (Standard), ordering code ...0...
- 3 Lock (optional), ordering code ...3...
- 4 Space required to remove key

**Ports**

Designation	Size
S Suction port	G3/4
P Pressure port	G1/2
L Case drain port	G1/4

**Notes for adjustments**

- ▶ Flow adjustment (1)
  - at clockwise rotation, decrease of flow
  - at counter clockwise rotation, increase of flow
- ▶ Pressure adjustment (2)
  - at clockwise rotation, increase of operating pressure
  - at counter clockwise rotation, decrease of operating pressure

 RE 10522/01.2013, **Bosch Rexroth AG**

Archivierung 10/2016

12 **PV7...A Series 1X / 2X** | Variable vane pump, direct controlled  
Project planning notes

### Project planning notes

When using vane pumps we recommend that the following instructions are particularly taken into account. Project planning, installation and commissioning of the vane pumps require the involvement of qualified personnel.

#### Technical data

All the technical data are dependent on manufacturing tolerances and are valid with certain operating conditions. Please therefore take into account that minor variations are possible and technical data can be affected by differing conditions (e.g. viscosity).

#### Characteristics for flow and absorbed power

Please take into account when dimensioning the engine the maximum possible application data.

#### Noise

The values for sound pressure levels as shown on pages 6 to 9 were measured according to DIN 45635 part 26. That means, only the noise emission of the pump is depicted. Ambient influences (such as place of installation, piping, etc.) are not taken into consideration. The values only refer to one pump.

#### Note

The power unit design and the influences at the unit's final place of installation, result in general in the fact that the sound pressure levels lie 5 to 10 dB(A) higher than that of the pump alone.

#### Case drain

On page 4 the average external case drain of the pump is stated. Consider, that these values are only meant to be project planning for determining cooler and pipeline sizes. The zero stroke power is the relevant factor for the dimensioning of the reservoir (see page 6 to 9). Restrictions in pipeline cross sections but also the use of a case drain cooler can cause impermissible high pressure spikes in the case drain line.

#### Pressure safeguarding

Pressure controller are not backups against pressure overload. A separate pressure-relief valve is to be provided in the hydraulic system.

## Installation instructions

### Fluid reservoir

- ▶ Match the usable reservoir volume to the operating conditions.
- ▶ The permissible fluid temperature may not be exceeded, if required, provide a cooler!

### Lines and ports

- ▶ Remove protective plugs from the pump.
- ▶ We recommend the use of seamless precision steel pipes according to DIN 2391 and removable pipe connections.
- ▶ Select the pipe inside diameters according to the port size.
- ▶ Thoroughly clean pipelines and fittings prior to installing.

### Proposal for laying of pipelines

Minimum dimension [mm]

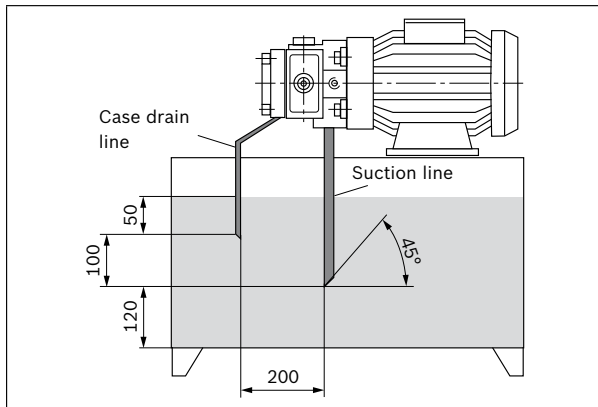

- ▶ The case drain line to install in such a manner, that the pump cannot drain empty!
- ▶ Under no circumstances may case drain and return fluid be directly taken up in the pump suction port!

### Filter

If possible, use return-line filters or pressure-line filters.  
(Suction filter only in conjunction with low pressure switch/  
clogging indicator)

### Hydraulic fluid

- ▶ Please observe our specifications according to data sheet 90220.
- ▶ We recommend brand name hydraulic fluids.
- ▶ Do not mix hydraulic fluids of different types since this can result in decomposition and deterioration of the lubricating quality.
- ▶ The hydraulic fluid must be replaced at regular intervals relevant to the operating conditions. In connection with this, the oil reservoir must also be cleaned of residues.

### Drive

Electric motor + pump support + coupling + pump

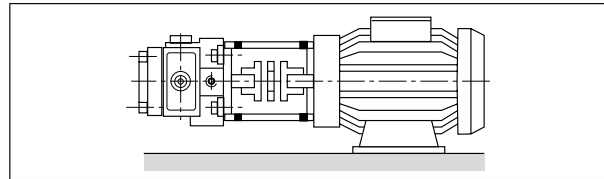

- ▶ No radial or axial forces permissible on the pump drive shaft!
- ▶ Motor and pump must be exactly aligned!
- ▶ Use torsionally flexible couplings.

### Installation position

Horizontal position preferred

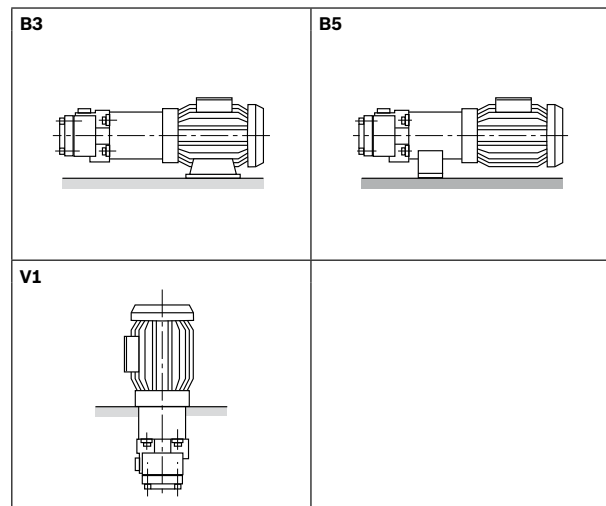

14 **PV7...A Series 1X / 2X** | Variable vane pump, direct controlled  
Commissioning instructions

## Commissioning instructions

### Air bleeding

- ▶ All of the PV7...A type vane pumps are self-priming.
- ▶ Before initial commissioning, the pump must be air-bleed to protect it against damage.
- ▶ During the initial commissioning, we recommend to fill the housing through the case drain line. Take into account the filter grade! This increases operating safety and prevents wear in the case of unfavorable installation conditions.
- ▶ If the pump flow is not bubble-free after approx. 20 seconds, the system has to be rechecked. After the operating values have been reached, check the pipe connections for leakage and check the operating temperature.

### Commissioning

- ▶ Check whether the system is thoroughly and properly installed.
- ▶ Take into account the motor and pump direction of rotation arrows.
- ▶ Start the pump without load and let the flow run without pressure for a few seconds in order to provide sufficient lubrication.
- ▶ **On no account let the pump run without hydraulic fluid!**

### Note

- ▶ Adjustment, maintenance and repair of the pump may only be carried out by authorized, trained and instructed personnel!
- ▶ Use only original Rexroth spare parts!
- ▶ The pump may only be operated within the permissible data.
- ▶ The pump may only be operated when in perfect condition!
- ▶ When carrying out any work on the pump (e.g. mounting and removal) switch the system to zero pressure and isolate from the mains supply!
- ▶ Unauthorized conversions and changes, affecting the safety and function are not permissible!
- ▶ Mount safety devices (e.g., coupling protection)!
- ▶ Do not remove any existing safety devices!
- ▶ The generally valid safety and accident prevention regulations must be adhered to!

**Bosch Rexroth AG**  
Mobile Applications  
Glockeraustraße 4  
89275 Elchingen, Germany  
Phone.: +49-7308-82-0  
info.ma@boschrexroth.de  
www.boschrexroth.com

© This document, as well as the data, specifications and other information set forth in it, are the exclusive property of Bosch Rexroth AG. It may not be reproduced or given to third parties without its consent. The data specified above only serve to describe the product. No statements concerning a certain condition or suitability for a certain application can be derived from our information. The information given does not release the user from the obligation of own judgment and verification. It must be remembered that our products are subject to a natural process of wear and aging.