

The series of pilot operated servo proportional valves D*1FP transfers the advantages of the Parker patented Voice Coil Drive (VCD®) to larger frame sizes and thus high flow rates. The high dynamics / high precision drive of the pilot valve allows the optimum control of the main spool and results in servo class performance of the complete valves.

The D*1FP series is available in 5 sizes:

- D31FP NG10 (CETOP 05)
- D41FP NG16 (CETOP 07)
- D81FP NG25 (CETOP 08) for port diam. up to 26 mm
- D91FP NG25 (CETOP 08) for port diam. up to 32 mm
- D111FP NG32 (CETOP 10)

The safety concept works with a safe 4th position at the D1FP pilot valve. This ensures that the main stage is hydraulically balanced at power down and allows to have the main spool spring centered (for overlapped spools) or approximately 10 % spring offset to spool position A or B (for zerolap spools).

The innovative integrated regenerative function into the A-line (optional) allows new energy saving circuits for differential cylinders. The hybrid version can be switched between regenerative mode and standard mode at any time.

Features

- High dynamics
- High flow
- Defined spool positioning at power-down - optional P-A/B-T or P-B/A-T or center position (for overlapped spools)
- Onboard electronics
- Energy saving A-regeneration
- Switchable hybrid version

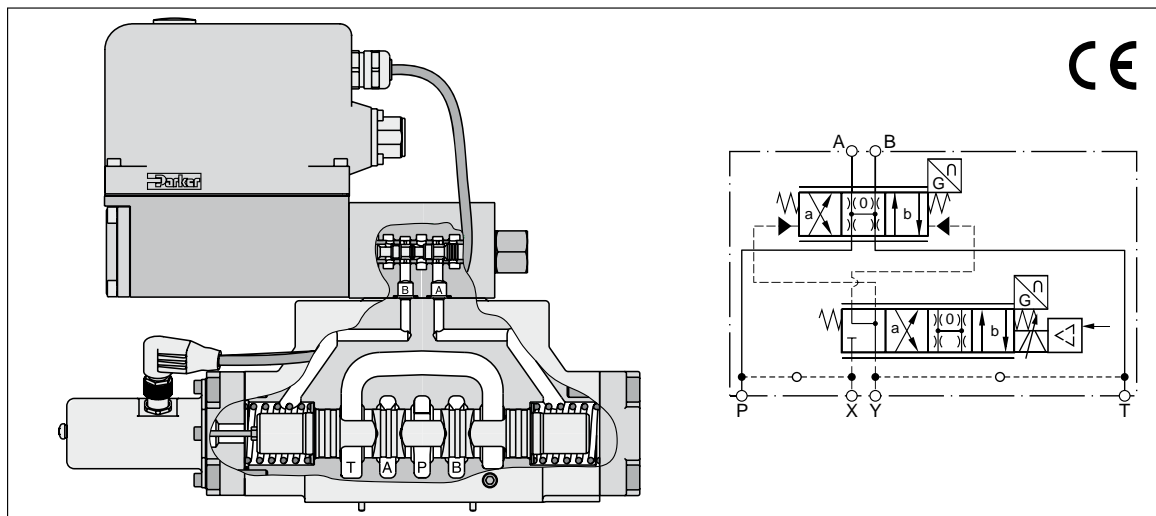
D41FPE52 (Standard)

D_1FP UK.indd RH 22.03.2016



D41FP Standard

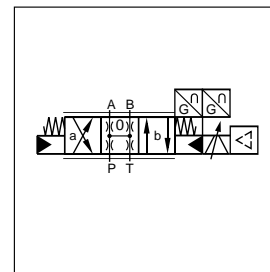

Standard D*1FPE

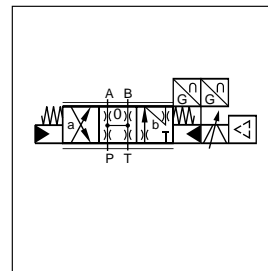

A-regeneration D*1FPR

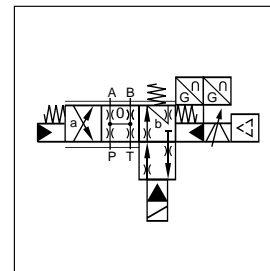

Hybrid D*1FPZ

3

Further literature about the opportunities of energy savings and more functional details of the integrated regeneration is available on request.

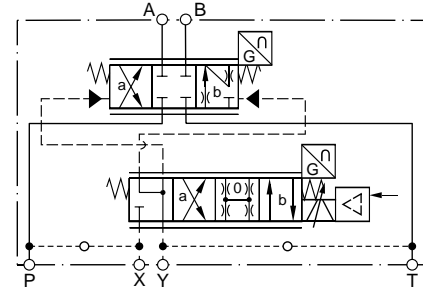
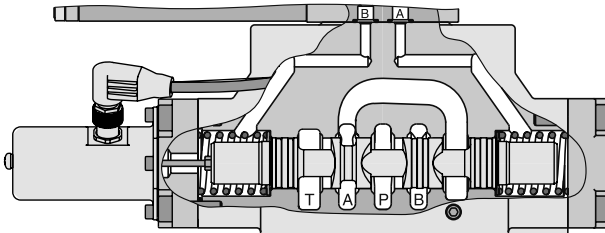
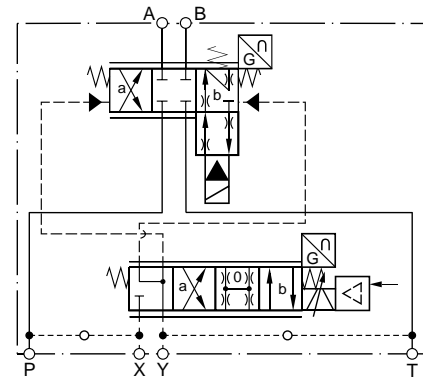
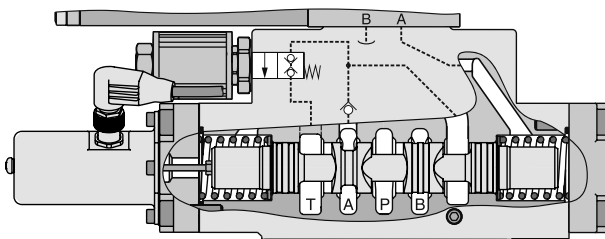
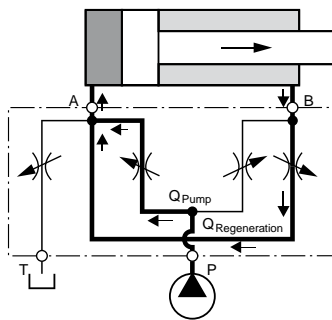
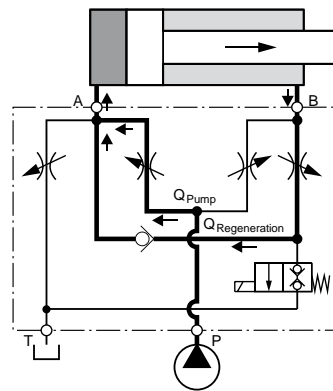
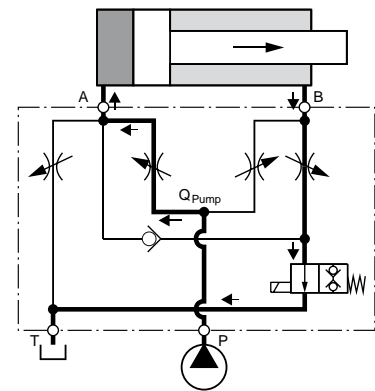
D*1FPR and D*1FPZ
3
Regenerative valve D*1FPR

Hybrid valve D*1FPZ

**D*1FPR (regenerative valve)
 Cylinder extending**

**D*1FPZ (hybrid valve)
 Cylinder extending
 in regenerative mode (high speed)**

**Cylinder extending
 in standard mode (high force)**

Flow rate in % of nominal flow

Size ¹⁾	Spool	Port					
		A-T	P-A	P-B	B-A (R-Valve)	B-A (Hybrid)	B-T (Hybrid)
D41FPR/Z	31/32/61	100 %	50 %	100 %	50 %	40 %	20 %
D91FPR/Z	31/32/61	100 %	50 %	100 %	50 %	50 %	25 %
D111FPR/Z	31/32/61	100 %	50 %	100 %	50 %	50 %	20 %

¹⁾ D31FP: For size NG10 please refer solution with sandwich- and adaptor plates "A10-1664 / A10-1665L / H10-1662 / H10-1666L" in chapter 12.

Catalogue HY11-3500/UK
Ordering Code
**Pilot Operated Servo Proportional DC Valve
 Series D*1FP**

D	1	F	P													
Directional control valve	Size	NG06 pilot	Proportional control	VCD performance	Function	Flow	Spool position on power down	Pilot connections	Seals	Command signal	Electronic options	Valve option	Design series (not required for ordering)			

Code	Size
3	NG10 / CETOP 05
4	NG16 / CETOP 07
8	NG25 / CETOP 08
9 ¹⁾	NG25 / CETOP 08
11	NG32 / CETOP 10

Code	Valve option
0	Standard for spool code B, E, R
L ⁷⁾	Hybrid valve 24 V normally closed for spool code Z

Code	Electronic options
0	6+PE acc. EN175201-804
5	11+PE acc. EN175201-804
7	6+PE + enable





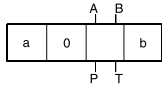
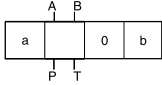
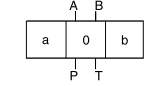

Code	Signal	Function
B	0...±10 V	0...+10 V P -> B
E	0...±20 mA	0...+20 mA P -> B
K	0...±10 V	0...+10 V P -> A
S	4...20 mA	12...20 mA P -> A



Code	Seals
N	NBR
V	FPM
H	for HFC fluid



Code	Inlet	Drain
1	internal	external
2	external	external
4	internal	internal
5	external	internal

Code	Spool pos. on power down
A ²⁾	
B ²⁾	
C ³⁾	

Code	Flow [l/min] at Δp = 5 bar per metering edge				
	D31	D41	D81	D91	D111
D	90	—	—	—	—
E	120	—	—	—	—
F	—	200	—	—	—
H	—	—	400	450	—
L	—	—	—	—	1000

Code	Spool type overlap
E01	
E02	
B31	$Q_{02} = Q_{01} / 2$ 
B32	$Q_{02} = Q_{01} / 2$ 
E52	
B61	$Q_{02} = Q_{01} / 2$ 

Code	Spool type overlap
R31	
R32	
R61	

Code	Spool type overlap
Z31	
Z32	
Z61	

3

 Please order connector separately. See chapter 3 accessories.
 Parametrizing cable OBE -> RS232, item no. 40982923

- 1) For enlarged connections Ø 32 mm.
- 2) Approx. 10 % opening, only zero lapped spools.
- 3) For overlapped spools.
- 4) Not for D81FP.
- 5) For regenerative and hybrid function at D31FP (NG10) please refer to solutions with sandwich and adaptor plates "A10-1664 / A10-1665L / H10-1662 / H10-1666L" in chapter 12.

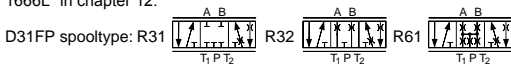

- 6) Not for valve D31FP and D81FP.
- 7) See page "Regenerative and hybrid function" (not for D31FP).

Short delivery time for all variations

D_1FP UK.indd RH 22.03.2016



3

General					
Design	Pilot operated servo proportional DC valve				
Actuation	VCD®-actuator				
Size	NG10 (CETOP 05)	NG16 (CETOP 07)	NG25 (CETOP 08)	NG32 (CETOP 10)	
	D31	D41	D81 / D91	D111	
Mounting Interface	DIN 24340 / ISO 4401 / CETOP RP121 / NFPA				
Mounting position	unrestricted				
Ambient temperature	[°C] -20...+50				
MTTF _D value ¹⁾	[years] 75				
Weight	11.3	14.2	23.5	64.5	
Vibration resistance	10 Sinus 5...2000 Hz acc. IEC 68-2-6 30 Random noise 20...2000 Hz acc. IEC 68-2-36 15 Shock acc. IEC 68-2-27				
Hydraulic					
Max. operating pressure	[bar]	Internal pilot drain P, A, B, X 350; T, Y 35 External pilot drain P, A, B, T, X 350; Y 35			
Fluid		Hydraulic oil according to DIN 51524 ... 535, other on request			
Fluid temperature	[°C]	-20...+60 (NBR: -25...+60)			
Viscosity permitted	[cSt]/[mm ² /s]	20...400			
Viscosity recommended	[cSt]/[mm ² /s]	30...80			
Filtration		ISO 4406 (1999); 18/16/13			
Nominal flow at Δp = 5 bar per control edge ²⁾	[l/min]	120	200	400 / 450	1000
Max. recommended flow (standard)	[l/min]	250	600	1000	3000
Regenerative B-A / B-T		depending on application, see flow curves			
Leakage at 100 bar	[ml/min]	200	200	600	1000
Overlapped spool	[ml/min]	900	900	1000	5000
Zerolapped spool	[ml/min]				
Pilot	[ml/min]	< 500			
Opening point	[%]	set to 10 command signal (see flow characteristics)			
Pilot supply pressure	[bar]	20...350			
Pilot flow during step response at 210 bar	[l/min]	10	12	24	40
Static / Dynamic					
Step response at 100 % stroke ³⁾	[ms]	10	13	19	45
Frequency response					
Amplitude ±5 % at 210 bar	[Hz]	128	95	95	40
Phase ±5 % at 210 bar	[Hz]	118	95	90	75
Hysteresis	[%]	< 0.1			
Sensitivity	[%]	< 0.05			
Temperature drift of center position	[%/K]	< 0.025			
Electrical					
Duty ratio	[%]	100			
Protection class		IP65 in accordance with EN 60529 (with correctly mounted plug-in connector)			
Supply voltage / ripple	[V]	22...30, ripple < 5 % eff., surge free			
Current consumption max.	[A]	3.5			
Pre-fusing	[A]	4.0 A medium lag			
Input signal	[V]	+10...0...-10, ripple < 0.01 % eff., surge free, 0...+10 V P→A (P→B)			
Code K (B)	Voltage				
	Impedance	100			
Code E	Current	+20...0...-20, ripple < 0.01 % eff., surge free, 0...+20 mA P→B			
	Impedance	<250			
Code S	Current	4...12...20, ripple < 0.01 % eff., surge free, 12...20 mA P→A			
	Impedance	<250			
Input Capacitance typ.	[nF]	1			
Differential input max.	[V]	30 for terminal D and E against PE (terminal G) 11 for terminal D and E against 0V (terminal B)			
	[V]	30 for terminal 4 and 5 against PE (terminal ↓) 11 for terminal 4 and 5 against 0V (terminal 2)			
	[V]	30 for terminal D and E against PE (terminal G)			
Enable signal	[V]	5...30, Ri > 8 kOhm			
Diagnostic signal	[V]	+10...0...-10 / +12.5 V (overload), rated max. 5 mA			
EMC		EN 61000-6-2, EN 61000-6-4			
Electrical connection	Code 0/7	6 + PE acc. EN 175201-804			
	Code 5	11 + PE acc. EN 175201-804			
Wiring min.	Code 0/7	7 x 1.0 (AWG16) overall braid shield			
	Code 5	8 x 1.0 (AWG16) overall braid shield			
Wiring length max.	[m]	50			

¹⁾ If valves with onboard electronics are used in safety-related parts of control systems, in case the safety function is requested, the valve electronics voltage supply is to be switched off by a suitable switching element with sufficient reliability.

²⁾ Flow rate for different Δp per control edge: $Q_x = Q_{Nom.} \cdot \sqrt{\frac{\Delta p_x}{\Delta p_{Nom.}}}$

³⁾ Measured with load (210 bar pressure drop/two control edges).

Electrical characteristics hybrid option

Duty ratio		100 %		
Protection class		IP 65 in accordance with EN 60529 (with correctly mounted plug-in connector)		
		D41	D91	D111
Supply voltage [V]		24	24	24
Tolerance supply voltage [%]		±10	±10	±10
Current consumption [A]		1.21	0.96	1.29
Power consumption [W]		29	23	31
Solenoid connection		Connector as per EN 175301-803		
Wiring min. [mm ²]		3 x 1.5 recommended		
Wiring length max. [m]		50 recommended		

With electrical connections the protective conductor (PE ↓) must be connected according to the relevant regulations.

3

Wiring

Code 0, 6 + PE acc. EN 175201-804

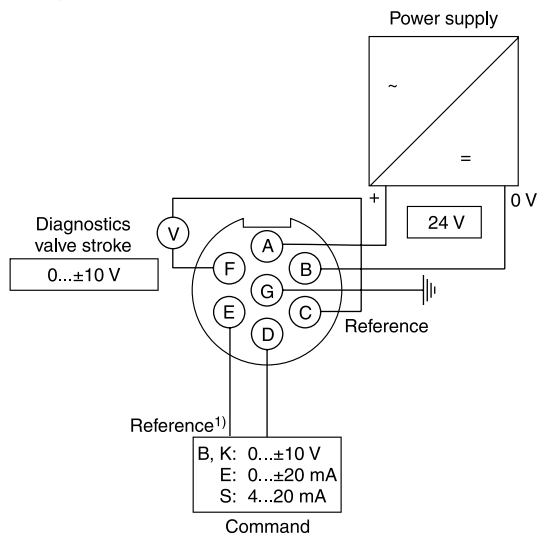

Code 5, 11 + PE acc. EN 175201-804

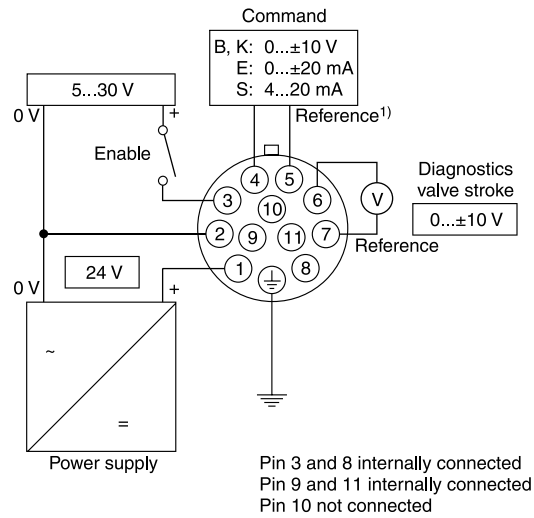

Code 7, 6 + PE acc. EN 175201-804 + enable

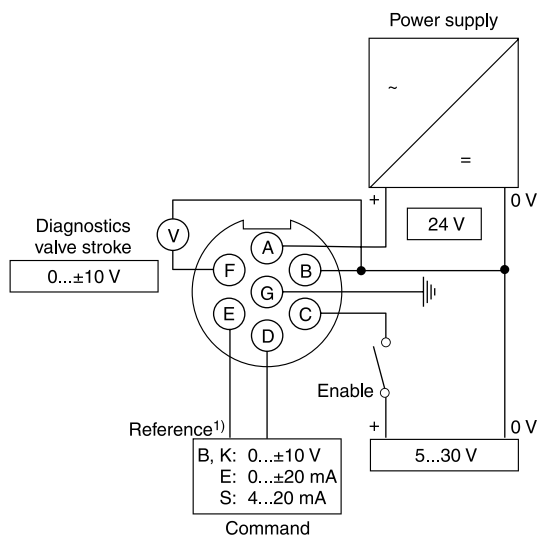

¹) Do not connect with supply voltage zero.

ProPxD interface program

The ProPxD software allows quick and easy setting of the digital valve electronics. Individual parameters as well as complete settings can be viewed, changed and saved via the comfortable user interface. Parameter sets saved in the non-volatile memory can be loaded to other valves of the same type or printed out for documentation purposes.

3

The PC software can be downloaded free of charge at www.parker.com/euro_hcd – see page “Support” or directly at www.parker.com/propxd.

Features

- Comfortable editing of valve parameters
- Saving and loading of customized parameter sets
- Executable with all Windows® operating systems from Windows® XP upwards
- Simple communication between PC and valve electronics via serial interface RS232C

The valve electronics cannot be connected to a PC with a standard USB cable – this can result in damages of PC and/or valve electronics.

The parametrizing cable may be ordered under item no. 40982923.

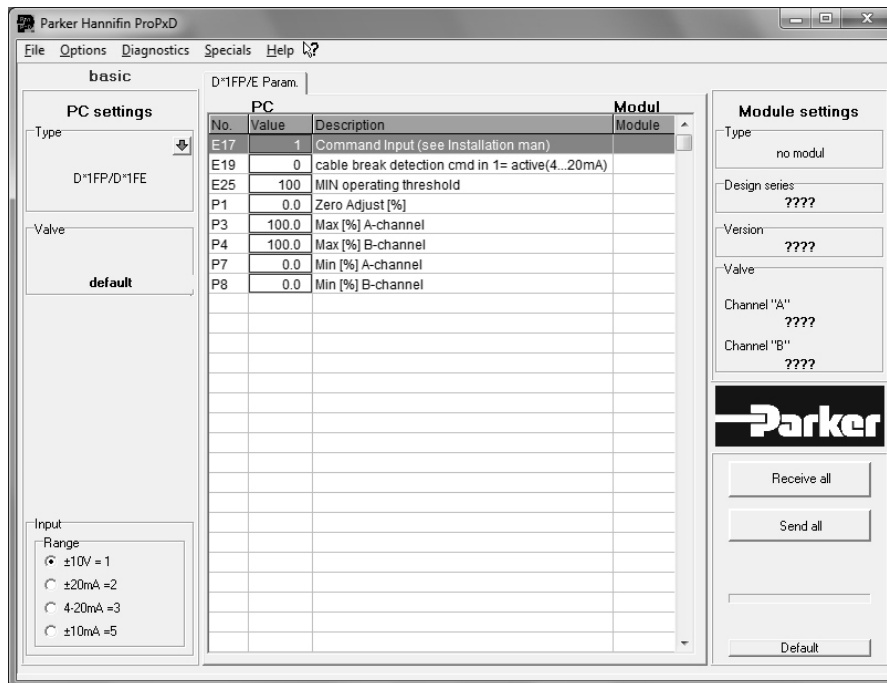

Frequency response

 ±5 % / ±25 % / ±90 % command signal
 Dynamics at 210 bar pilot supply pressure

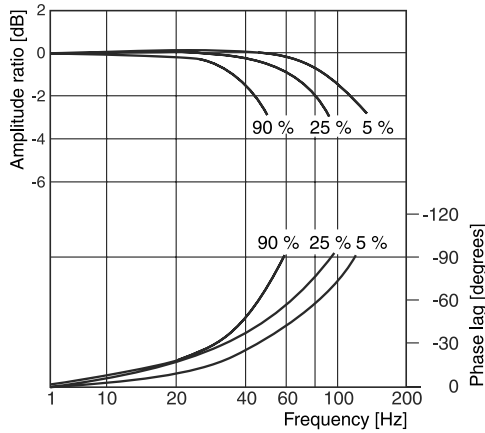
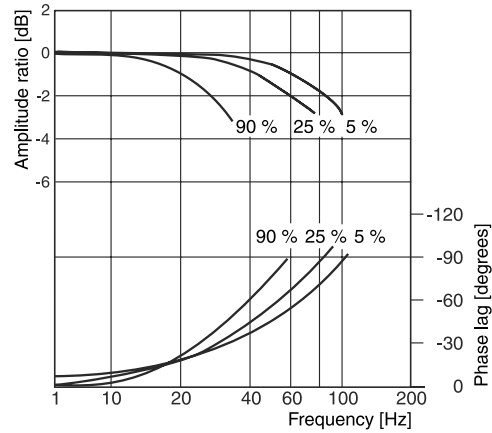
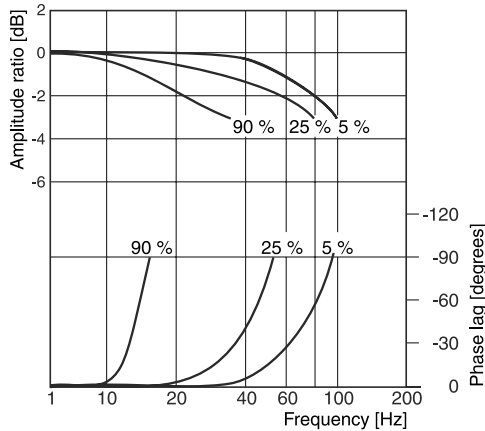
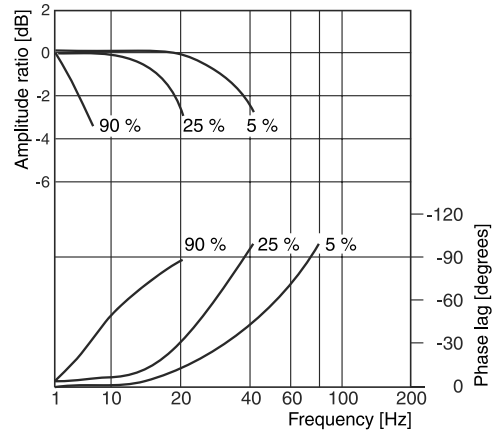
D31FP

D41FP

3
D81/91FP

D111FP

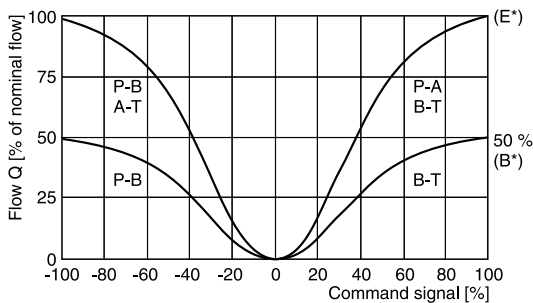
Flow curves D*1FPB/E

 (Overlapped spool set to opening point 10 %)
 at $\Delta p = 5$ bar per metering edge

D31FP

spool type E01/02/52, B31/32/61

D41FP

spool type E01/02/52, B31/32/61

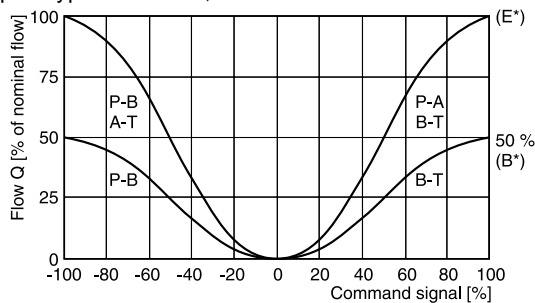

All characteristic curves measured with HLP46 at 50 °C.

D_1FP UK.indd RH 22.03.2016

3
Flow curves
D81/91FP

Spool type E01/02/52, B31/32/61

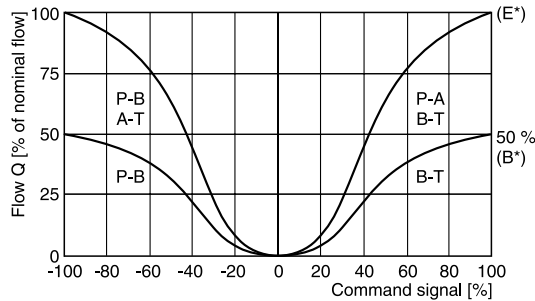
D111FP

Spool type E01/02/52, B31/32/61

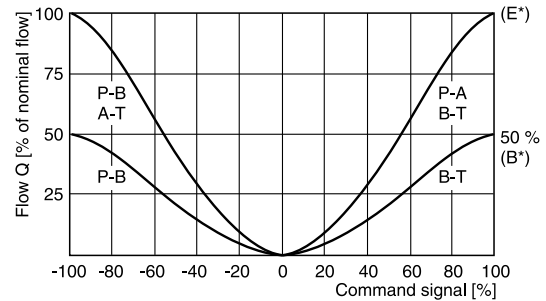
Flow curves D*1FPR/Z

 (Overlapped spool set to opening point 10 %
 at $\Delta p = 5$ bar per metering edge)

D31FP

Spool type R31/32/61

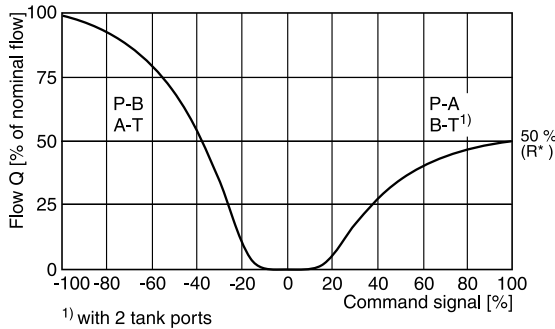
D41FP

Spool type R/Z 31/32/61

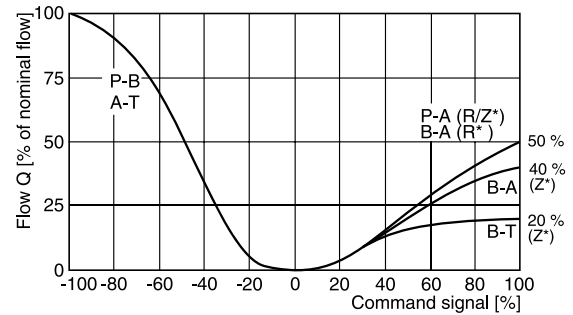
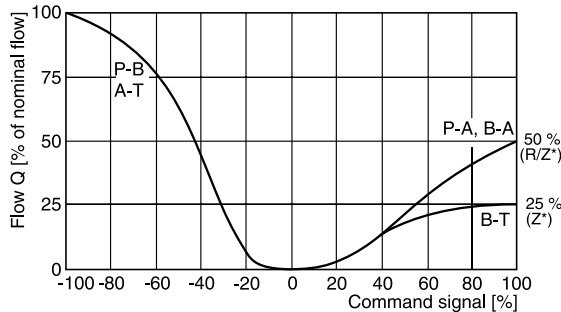
D91FP spool type R/Z 31/32/61

D111FP

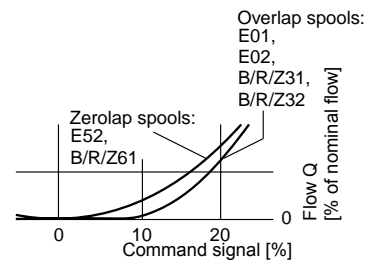
spool type R/Z* on request

Detail:
Standard, regenerative and hybrid flow curves

Pilot oil inlet (supply) and outlet (drain)

○ open, ● closed



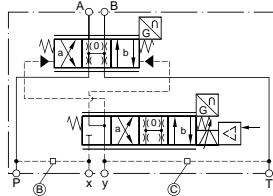
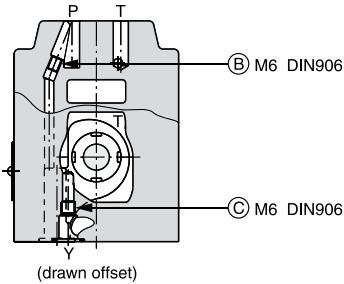
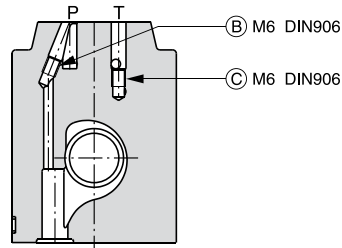
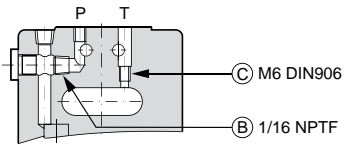
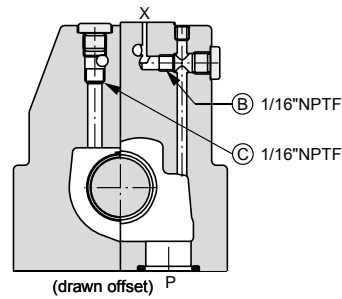
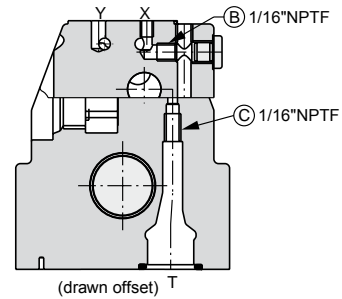
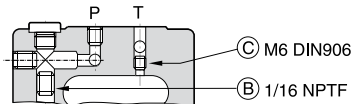
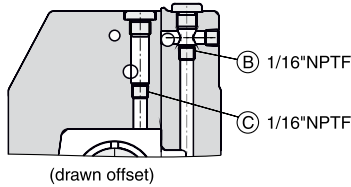
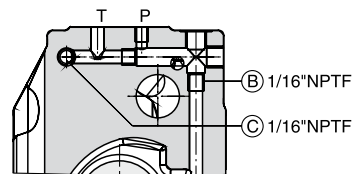
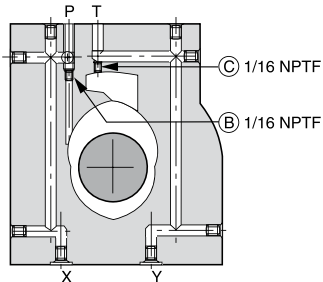
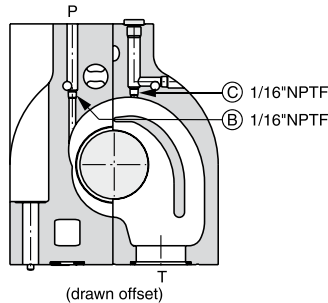
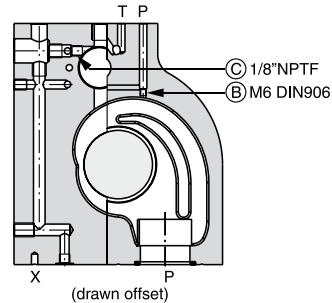

Pilot oil		B	C
Inlet	Drain		
internal	external	○	●
external	external	●	●
internal	internal	○	○
external	internal	●	○

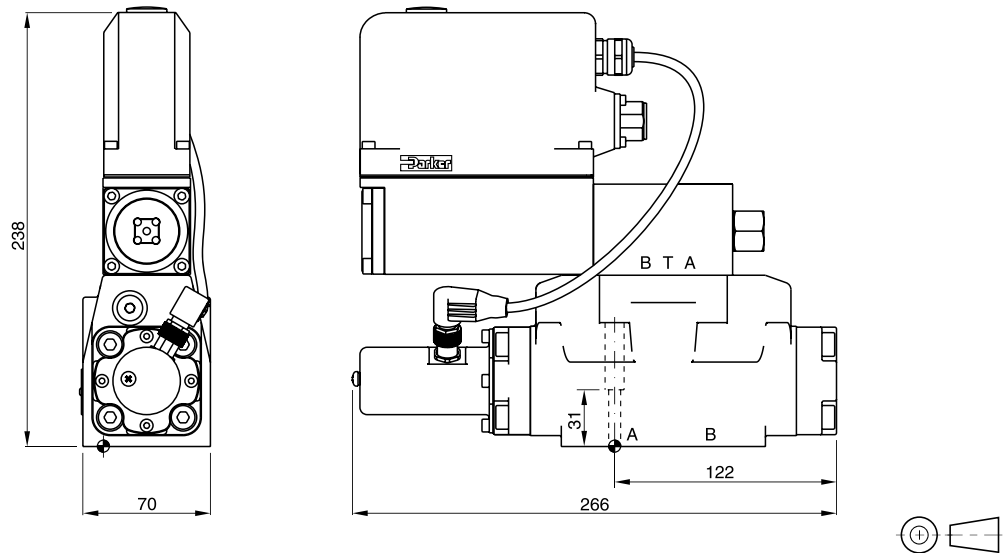

3
D31FPB/E

D31FPR

D41FPB/E

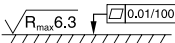
D41FPR

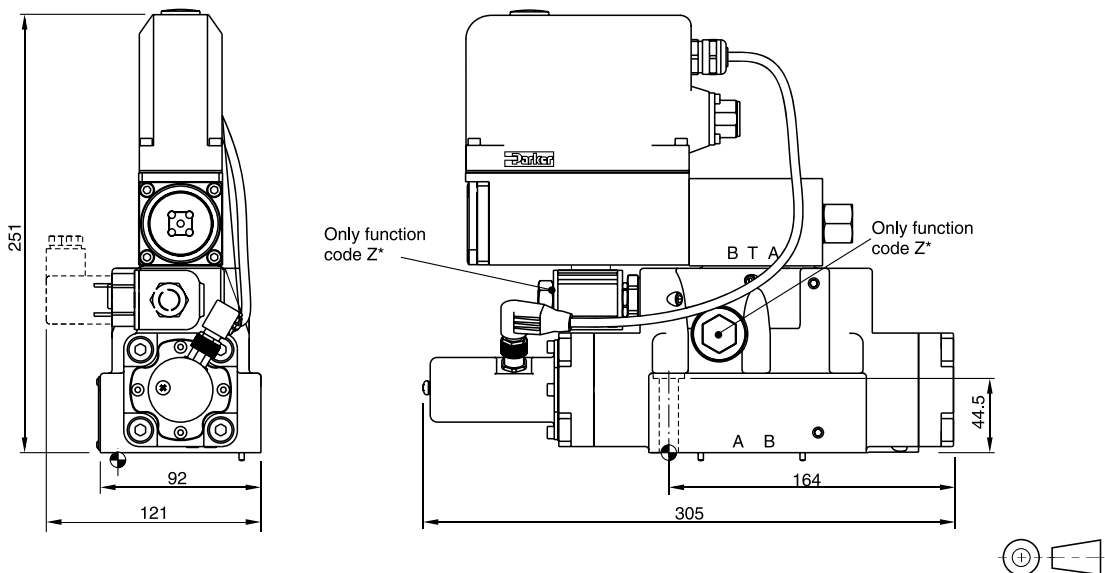
D41FPZ

D91FPB/E

D91FPR

D91FPZ

D111FPB/E

D111FPR

D111FPZ





D_1FP UK.indd RH 22.03.2016

3
D31FP

Regenerative and hybrid function with additional plate "A10-1664 / A10-1665L / H10-1662 / H10-1666L", see chapter 12.



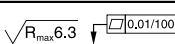

Surface finish	 Kit	 Kit	 Kit	 Kit
	BK385	4x M6x40 ISO 4762-12.9	13.2 Nm ±15 %	NBR: SK-D31FP FPM: SK-D31FP-V

D41FP

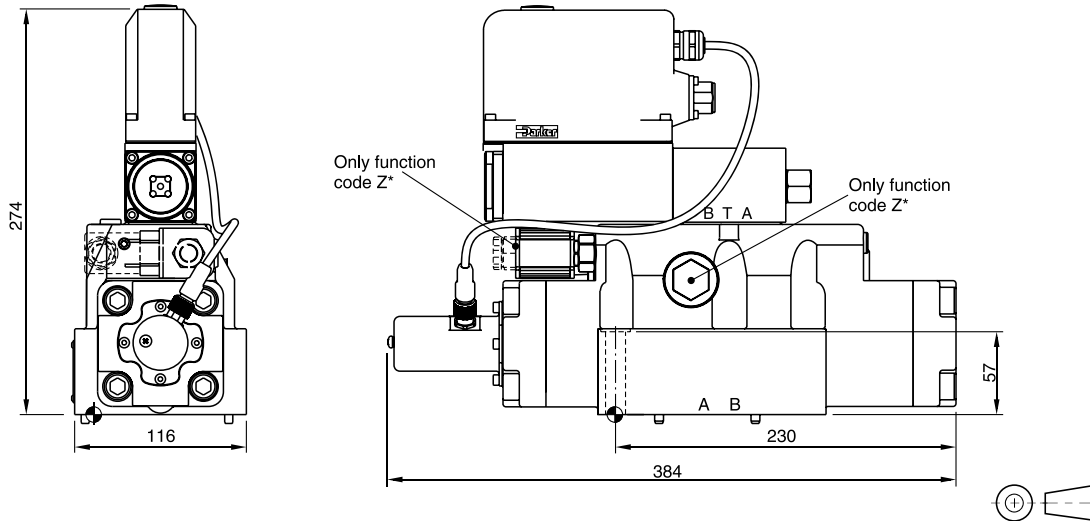



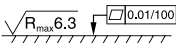

Surface finish	 Kit	 Kit	 Kit	 Kit
	BK320	2x M6x55 4x M10x60 ISO 4762-12.9	13.2 Nm ±15 % 63 Nm ±15 %	NBR: SK-D41FP FPM: SK-D41FP-V

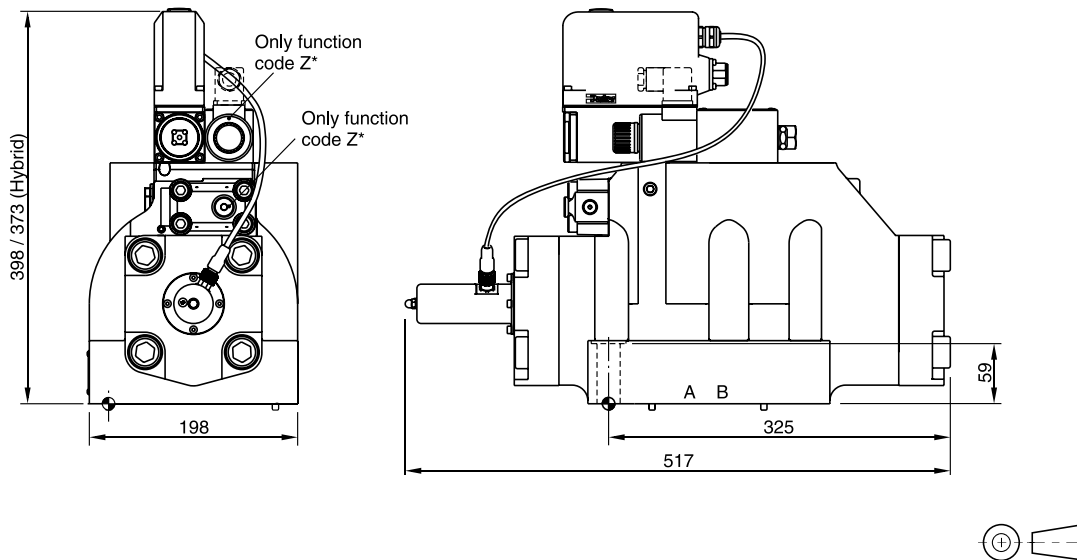
D_1FP UK.indd RH 22.03.2016

D81/91FP

3

Surface finish	 Kit	 Kit	 Kit	 Kit
	BK360	6x M12x75 ISO 4762-12.9	108 Nm ±15 %	NBR: SK-D81/D91FP FPM: SK-D81/D91FP-V

D111FP

Surface finish	 Kit	 Kit	 Kit	 Kit
	BK386	6x M20x90 ISO 4762-12.9	517 Nm ±15 %	NBR: SK-D111FP FPM: SK-D111FP-V