

# HYDAC INTERNATIONAL

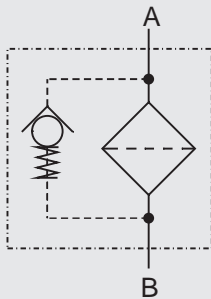

## MDF Pressure filter

Symbol for hydraulic systems:



### 1. SIZES

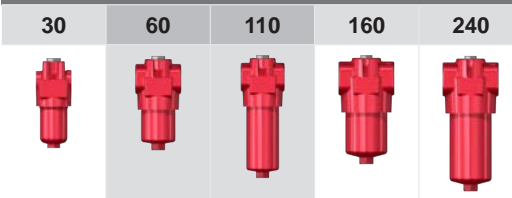

### 2. TECHNICAL DATA

#### Filter specifications

Nominal pressure	280 bar
Maximum flow rate	280 l/min
Temperature range	-30 °C to + 100 °C (-30 °C to -10°C: max. 140 bar)

Material of filter head	EN-GJS-400-15
Material of filter bowl	Steel

#### Clogging indicator

Type	VD
Pressure setting	5.0 bar

#### Bypass (optional)

Cracking pressure	6.0 bar
-------------------	---------

#### Miscellaneous

Seal	NBR (= Perbunan)
Mounting	As inline filter
Special models and accessories	<ul style="list-style-type: none"> <li>• Bypass valve built into the head, separate from the main flow</li> <li>• Oil drain plug</li> <li>• Seals in FKM</li> <li>• Test and approval certificates</li> </ul>
Spare parts	See spare parts list.
Certificates and approvals	<ul style="list-style-type: none"> <li>• Test certificate 2.2</li> <li>• Manufacturer's certificate O and M to DIN 55350, part 18</li> <li>• Others on request</li> </ul>

### 3. GENERAL DESCRIPTION

#### 3.1 FILTER HOUSING

##### Design

The filter housings are designed in accordance with international regulations. They consist of a filter head and a screw-in filter bowl.

##### Standard model

- without bypass valve
- connection for a clogging indicator in filter head
- mounting holes in the filter head

#### 3.2 FILTER ELEMENTS

HYDAC filter elements are validated and their quality is constantly monitored according to the following standards: ISO 2941, ISO 2942, ISO 2943, ISO 3724, ISO 3968, ISO 11170, ISO 16889.

Filter elements are available with the following collapse pressure stability values:

Designation	Model code	Collapse pressure
Optimicron®	ON	20 bar
Betamicron®	BH4HC	210 bar
Wire mesh	W	20 bar

#### 3.3 FATIGUE STRENGTH

##### Design

The fatigue strength is at least 5 million cycles at 1.2 times the nominal pressure.

Other pressures can be obtained from the diagram:

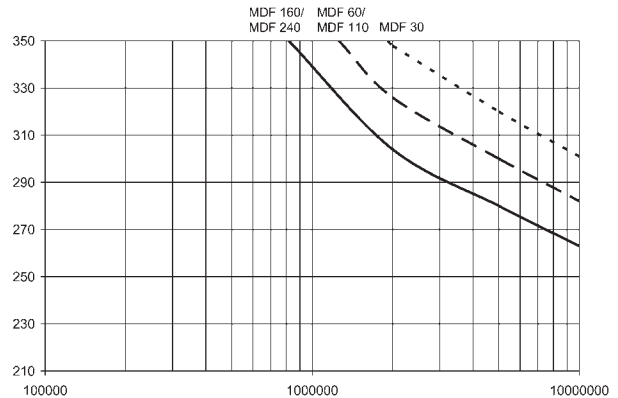

#### 3.4 COMPATIBILITY WITH HYDRAULIC FLUIDS (ISO 2943)

- Hydraulic oils HL to HVLP (DIN 51524)
- Lubrication oils (DIN 51517, API, ACEA, DIN 51515, ISO 6743)
- Compressor oils (DIN 51506)
- Biodegradable operating fluids: HETG, HEES, HEPG (VDMA 24568)
- Fire-resistant fluids HFA, HFB, HFC, HFD (ISO 12922)
- Operating fluids with a high water content (>50% water content) on request

#### 3.5 IMPORTANT INFORMATION

- The filter housings must be earthed e.g. via the system/pipe.
- When using electrical clogging indicators, the electrical power supply to the system must be switched off before removing the clogging indicator connector.

## 4. MODEL CODE

### 4.1 FILTER ASSEMBLY

**MDF ON 60 O C 10 D 1 . X /-L24**
**Filter type**

MDF

**Filter material**

 ON Optimicron®  
 BH/HC Betamicron®  
 W stainless steel wire mesh

**Size of filter or element**

30, 60, 110, 160, 240

**Operating pressure**

O 280 bar

**Type and size of connection**

Type	Connection	Filter size				
		30	60	110	160	240
B	G½	•				
C	G¾		•	•		
E	G1¼				•	•

**Filtration rating in µm**

 ON 3, 5, 10, 20  
 BH/HC 3, 5, 10, 20  
 W 25, 50, 100, 200

**Type of clogging indicator**

 A with steel blanking plug in indicator port  
 B visual  
 C electrical  
 D visual and electrical

**Type code**

1

**Modification number**

X the latest version is always supplied

**Supplementary details**

 B. bypass cracking pressure (e.g. B6 = 6 bar); without details = without bypass valve  
 L... lamp with appropriate voltage (24V, 48V, 110V, 220V)  
 V FKM seals

### 4.2 REPLACEMENT ELEMENT

**0060 D 010 ON /-V**
**Size**

0030, 0060, 0110, 0160, 0240

**Type**

D

**Filtration rating in µm**

 ON 003, 005, 010, 020  
 BH4HC 003, 005, 010, 020  
 W 025, 050, 100, 200

**Filter material**

ON, BH4HC, W

**Supplementary details**

V FKM seal

### 4.3 CLOGGING INDICATOR

**VD 5 D . X /-L24**
**Type**

VD differential pressure indicator up to 420 bar operating pressure

**Pressure setting**

5 standard 5 bar

**Type of clogging indicator**

D see point 4.1

**Modification number**

X the latest version is always supplied

**Supplementary details**

 L... lamp with appropriate voltage (24V, 48V, 110V, 220V)  
 V FKM seals

## 5. FILTER CALCULATION

The total pressure drop of a filter at a particular **flow rate Q** and **viscosity  $\nu$**  consists of the sum of the **housing pressure drop  $\Delta p_{\text{housing}}$**  and the **element differential pressure  $\Delta p_{\text{element}}$**  and can be calculated as follows:

$$\Delta p_{\text{total}} = \Delta p_{\text{housing}} + \Delta p_{\text{element}}$$

$$\Delta p_{\text{housing}} [\text{bar}] = \text{see housing curves}$$

$$\Delta p_{\text{element}} [\text{bar}] = Q [\text{l/min}] \cdot \frac{\text{SK} [\text{mbar} / (\text{l/min})]}{1000} \cdot \frac{\nu [\text{mm}^2/\text{s}]}{30}$$

SK = gradient coefficient (see point 5.2)

For ease of calculation, our Filter Sizing Program is available free of charge at:

[www.hydac.com/de-en/service/online-tools](http://www.hydac.com/de-en/service/online-tools)

### 5.1 HOUSING CURVES

The housing curves are based on ISO 3968. The housing curves apply to mineral oil with a density of 0.86 kg/dm<sup>3</sup> and a kinematic viscosity of 30 mm<sup>2</sup>/s.

In this case, the differential pressure changes proportionally to the density.

#### MDF 30

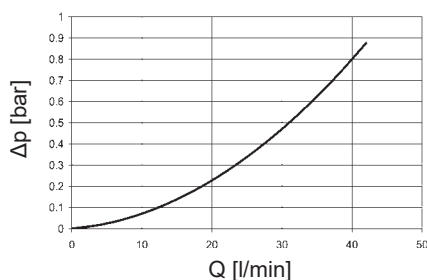

#### MDF 60-110

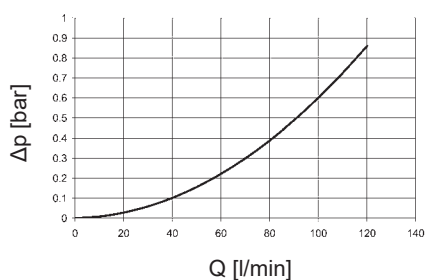

#### MDF 160-240

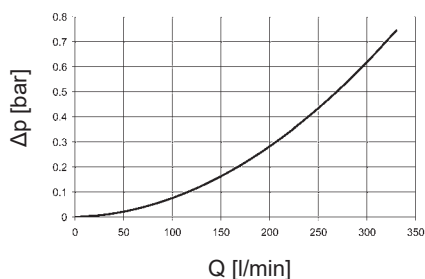

### 5.2 GRADIENT COEFFICIENTS (SK)

The gradient coefficients in mbar/(l/min) apply to mineral oils with a kinematic viscosity of 30 mm<sup>2</sup>/s. The pressure drop changes proportionally to the change in viscosity.

Size	ON				W
	3 μm	5 μm	10 μm	20 μm	
30	63.90	43.60	22.80	11.30	3.030
60	26.00	18.30	12.10	6.32	0.757
110	13.40	9.61	6.06	2.99	0.413
160	11.00	7.70	4.10	3.18	0.284
240	6.90	5.34	3.19	2.10	0.189

Size	BH4HC			
	3 μm	5 μm	10 μm	20 μm
30	91.2	50.7	36.3	19.0
60	58.6	32.6	18.1	12.2
110	25.4	14.9	8.9	5.6
160	16.8	10.4	5.9	4.4
240	10.6	6.8	3.9	2.9

### 5.3 MAXIMUM FLOW RATE

The following maximum permitted flow rates ( $Q_{\text{max}}$ ) in l/min are possible for the various sizes and connection sizes:

Size	Connection	$Q_{\text{max}}$
		[l/min]
30	B	30
60	C	80
110	C	110
160	E	260
240	E	280

#### Information regarding calculation:

The hydraulic load on the filter element is primarily determined by the flow rate and the geometry of the particular filter element. Exceeding the maximum permitted flow rate ( $Q_{\text{max}}$ ) and therefore the permitted hydraulic load can destroy the filter element.

Even the choice of operating medium can influence system performance and lead to problems during use such as electrostatic discharges.

Adherence to the maximum permitted flow rate should always be ensured throughout the system project planning process.

If you have any questions regarding calculation or project planning, please contact the technical sales department at HYDAC Filtrertechnik.

## 6. DIMENSIONS

### NOTICE:

The MDF filter dimensions for **version 1.3** are slightly different to those for version 1.0.

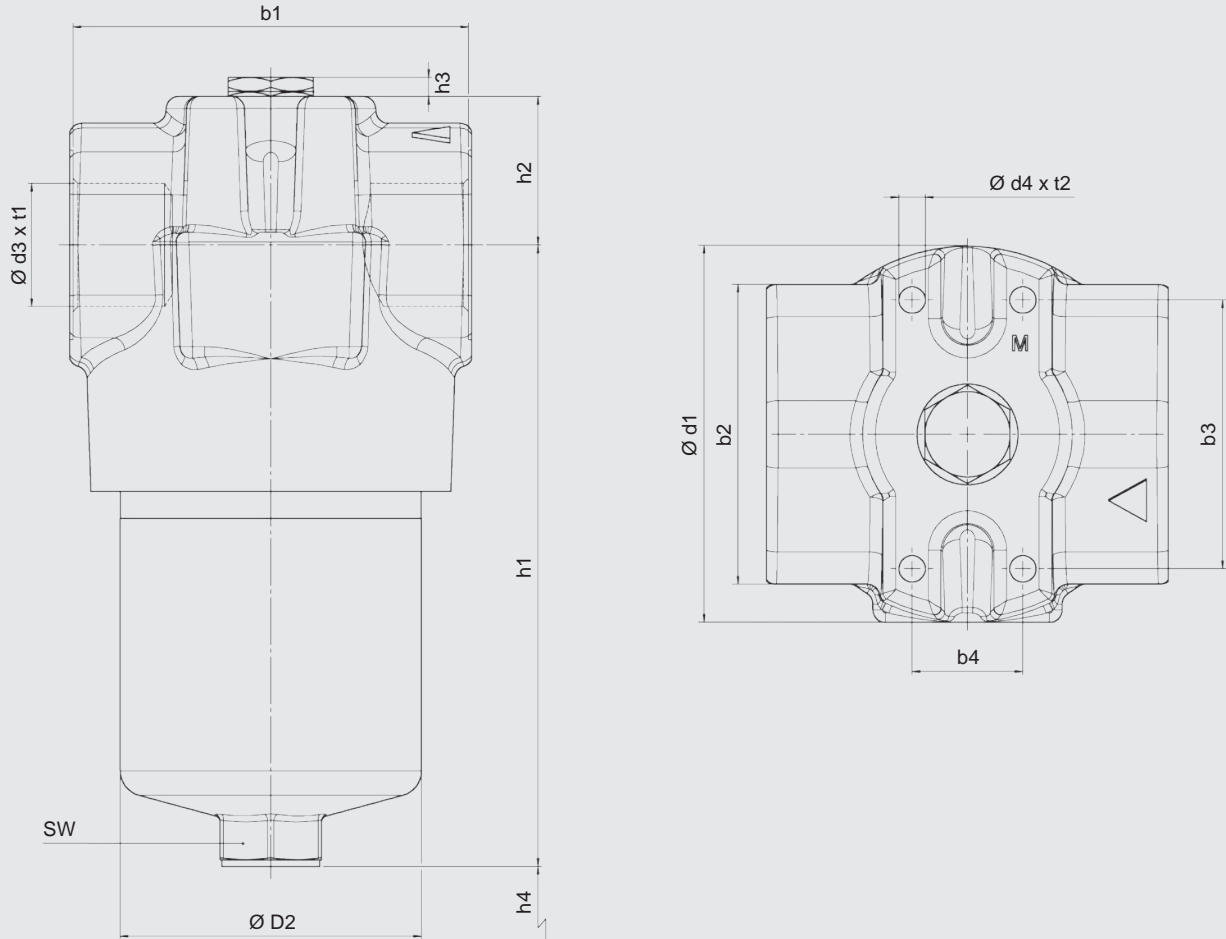

Size	b1	b2	b3	b4	d1	d2	d3	d4	h1	h2	h3	h4	AF width	t1	t2	Weight incl. element [kg]	Volume of pressure chamber [l]
30	68	38	45	30	69	52	G ½	M5	130.5	38	6	75	24	14	6	2.3	0.13
60	90	71	56	32	86	68	G ¾	M6	144	40	6	85	27	16	9	4.5	0.20
110	90	71	56	32	86	68	G ¾	M6	213.5	40	6	85	27	16	9	5.4	0.33
160	125	95	85	35	119	95	G 1¼	M10	197	47	6	105	32	20	14	10.2	0.60
240	125	95	85	35	119	95	G 1¼	M10	256	47	6	105	32	20	14	11.7	0.80

### NOTE

The information in this brochure relates to the operating conditions and applications described.

For applications and/or operating conditions not described, please contact the relevant technical department.

Subject to technical modifications.

**HYDAC Filbertechnik GmbH**  
 Industriegebiet  
**D-66280 Sulzbach/Saar**  
 Tel.: 0 68 97 / 509-01  
 Fax: 0 68 97 / 509-300  
 Internet: [www.hydac.com](http://www.hydac.com)  
 E-mail: [filter@hydac.com](mailto:filter@hydac.com)

EN 7.502.5/12.19

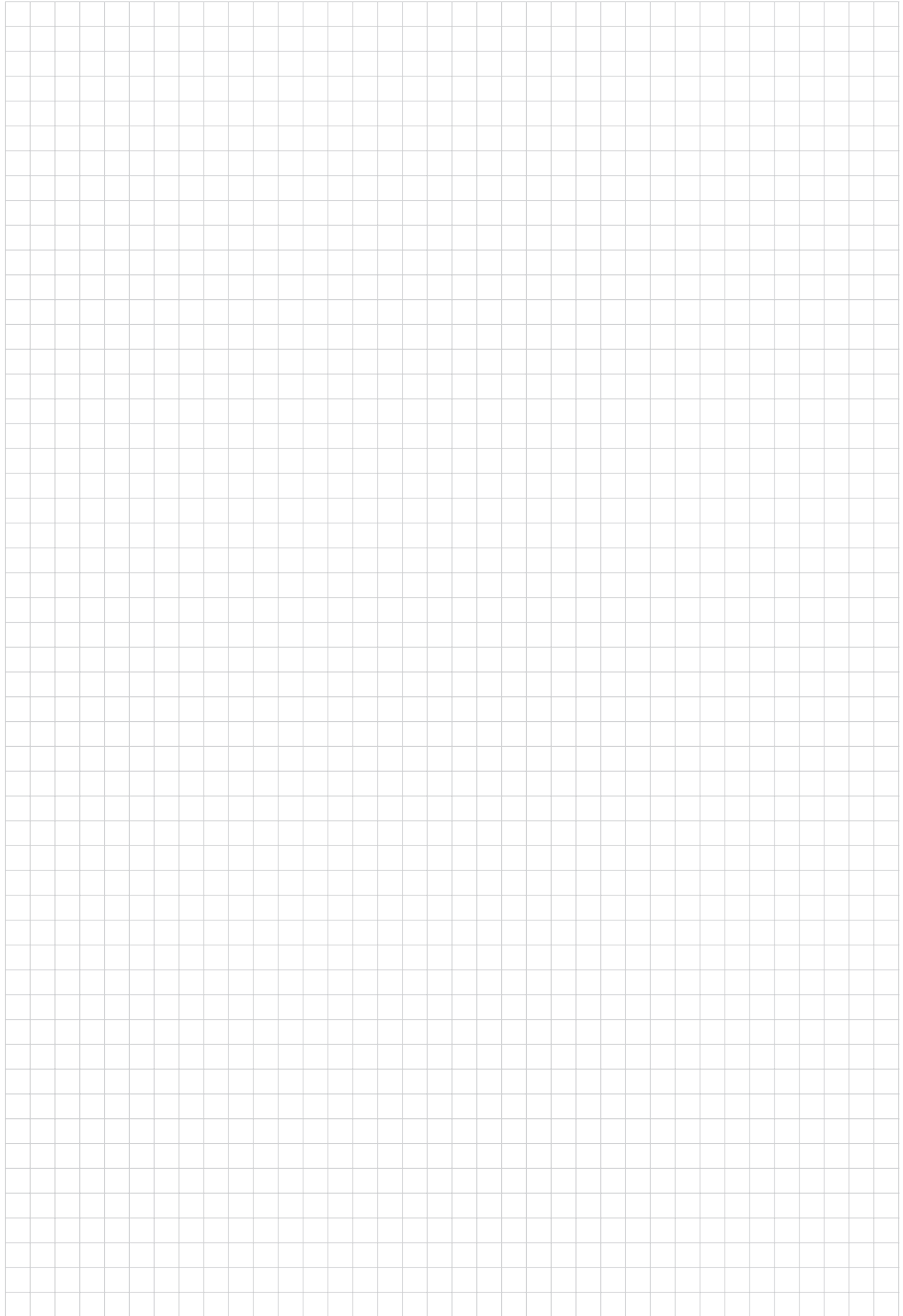

EN 7.502.5/12.19