

**Single-phase motor FBS 80 B 4/HT**

AB08B4200013-P : V099161 : : :

**General data**

Kind of motor	1~
Type designation	FBS
Frame size	80
Mounting form	B14a
Frame material	Aluminium
Insulation class	F
Terminal box location	top DE
Terminal box orientation	90° cable gland NDE
Weight (kg)	9,60
Rotation Direction	right /left
Vibration level	A
Balancing method	half key
cooling type	IC411
Executed acc. to	IEC 60034-1
noise level	IEC 60034-9

**Electrical data**

Power 1 50Hz (kW)	0,75
Frequency (Hz)	50
Voltage 50Hz (V)	230
Voltage/Frequency tolerance (not valid for range voltage)	range B
Poles	4
Efficiency 100% 50Hz (%)	71,0
Power factor	0,92
Starting current (I <sub>a</sub> /I <sub>n</sub> )	5,7
Starting torque (M <sub>a</sub> /M <sub>n</sub> )	2,5
Breakdown torque (M <sub>k</sub> /M <sub>n</sub> )	2,5
Current 50Hz (A)	4,99

**Motor characteristics**

Color	RAL7030
Paint surface	shiny
Protection class	IP55
Cable gland size (cable connection)	1xM20x1,5 1xblind plug
Cable gland type	Standard
Shaft end (mm)	19 x 40
Shaft material	C45
Specification NDE	Plastic fan
Flange size	120

**Motor characteristics of single-phase motors**

Capacitor	starting + operating condensator
S.C. Capacity	100 myF/300 V
O.C. Capacity	30 myF/450 V
run-up switching	centrifugal switch

**Mechanical data**

Torque (Nm)	5,12
Rotation speed (1/min)	1400
Bearing DE	6204.ZZ.C3
Bearing NDE	6204.ZZ.C3
Mounting of bearing DE	loose bearing
Mounting of bearing NDE	loose bearing
Bearing lifetime (h)	20000
allow. Radial load (X/2) (N)	700
allow. Radial load (X0) (N)	775
allow. Radial load (Xmax) (N)	625
allow. Axial load B3,B5,B35,B14,B34 (N)	625
allow. Axial load V1,V3,V19,V18 (N)	595
Moment of inertia (kgm <sup>2</sup> )	0,007688

**Influencing factors**

Duty	S1
Ambient temperature (°C)	-20 up to +40
Height of location (m)	1000

Technical changes and errors reserved.

16.10.2020

AC-Motoren GmbH  
Einsteinstraße 17  
D-64859 EppertshausenTelefon 06071 / 49887-0  
Telefax 06071 / 49887-20  
e-Mail: kontakt@ac-motoren.deSparkasse Dieburg  
IBAN: DE87508526510148011521  
BIC: HELADEF1DIEPostbank Frankfurt  
IBAN: DE80 5001 0060 0750 844604  
BIC: PBNKDEFFAmtsgericht Darmstadt, HRB Nr. 92769 · UStID.: DE812 439 558 · Geschäftsführer: Timo A. Klusmann  
Archivierung 10/2020www. **AC-Motoren** .de

## Drawings

**Single-phase motor FBS 80 B 4/HT**  
**AB08B4200013-P : V099161 : : :**

Die Zeichnung dient lediglich als Skizze um Maße darzustellen. Das gelieferte Produkt kann von dieser Skizze abweichen. Die detaillierte Beschreibung des Produkts befindet sich im Datenabschnitt (Seite 1).  
 The drawing serves only as a sketch to show dimensions. The delivered product may differ from this sketch. The detailed description of the product can be found in the Data section (page 1).

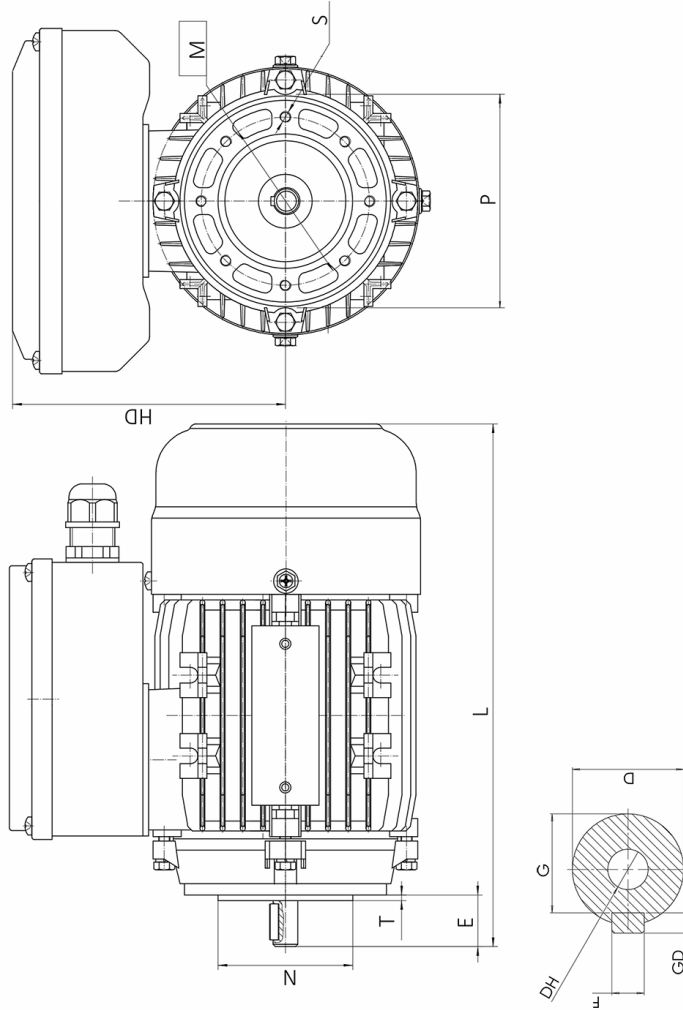

S	M6	T	3,50	HD	144,00	P	120	N	80	M	100	DH	M6x16	G	15,50	L	295,00	F	6	E	40	D	19
---	----	---	------	----	--------	---	-----	---	----	---	-----	----	-------	---	-------	---	--------	---	---	---	----	---	----