

Data Sheet

DP570 Series PLUS+1[®] Mobile Machine Displays

The Danfoss DP570 Series is an element of the PLUS+1[®] family of mobile machine management products.

The DP570 is designed to perform in the most extreme mobile machine environments.

The DP570 offers a variety of different options to meet your application needs.

The latest technology with backlight provides outstanding brightness and contrast performance resulting in an easy-to-read screen.

Develop and customize your display using PLUS+1[®] GUIDE and the GUIDE Vector Based Screen Editor (VBSE).



Features

- 5.7" high resolution Thin-Film-Transistor display, 640 x 480 pixels, 18-bit color
- One optional video input with both PAL and NTSC support
- LCD Brightness 370 cd/m²
- LCD Contrast 600:1
- Ideal for gauges, diagnostic menus, and other ancillary functions
- User-programmable with PLUS+1[®] GUIDE (Graphical User Integrated Development Environment)
- Two multifunction inputs that include DIN/ AIN/FreqIN/Rheo/4-20 mA
- Protective glass provides superior antiglare and contrast control under all light conditions
- Two mounting options:
 - Flush mount in dashboard
 - Stand-alone post mount according to VESA standard: 75 mm x 75 mm (2.953 in x 2.953 in)
- Integrated light sensor for automatic backlight adjustment
- Digital output for external alarm buzzer
- On board real-time clock
- CE compliant
- Fully integrated connectors and silicone keypad provide water and dust protection from all sides
- All buttons have white backlight design for low light and night use, all are individually software controlled

Comprehensive technical literature is
online at powersolutions.danfoss.com

Dimensions and connectors

DP570 dimensions (mm [in]); C1, C2 connectors

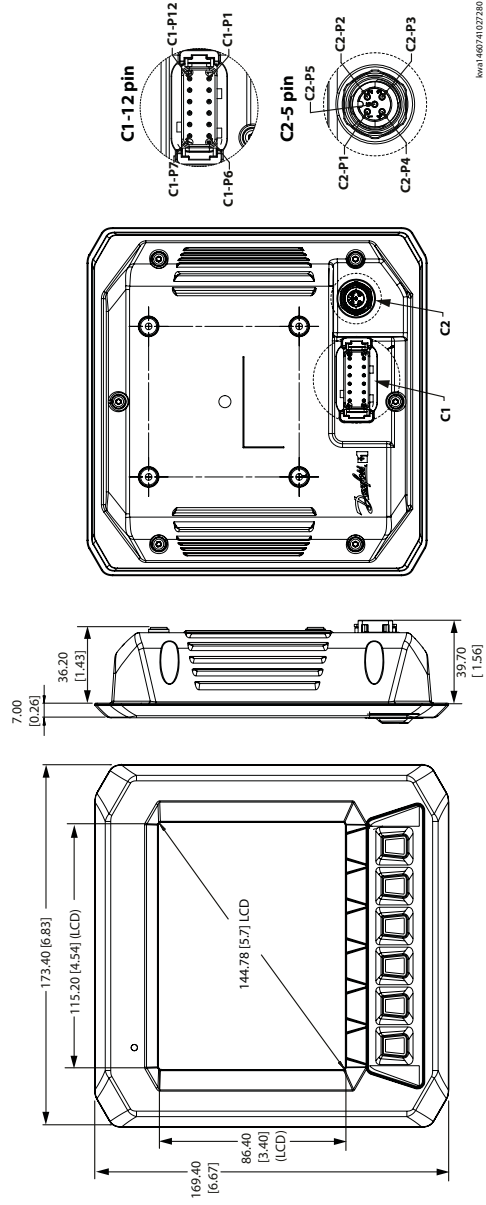

Wahl 1402/14027280

Pin assignments

C1—DEUTSCH DTMO6 12 pin

Pin	Function	Pins	Function
C1-P1	Power GND -	C1-P7	CAN1 Low - (DIN/AIN)
C1-P2	Power input +	C1-P8	DIN/AIN/4-20 mA
C1-P3	CAN0 High +	C1-P9	DIN/AIN/4-20 mA
C1-P4	CAN0 Low -	C1-P10	Multifunction-input
C1-P5	CAN shield	C1-P11	Multifunction-input
C1-P6	CAN1 High + (DIN/AIN)	C1-P12	DOUT

C2—M12 5 pin

Pin	Function
C2-P1	Video power GND
C2-P2	Video power supply
C2-P3	Video signal input 1
C2-P4	Video signal input GND
C2-P5	NC

Specifications

Processor	ARM11, 532 MHz
RAM	128 MB
FRAM	8 kB
Supply voltage / current consumption	9 to 36 V _{DC} / 0.5A at 12V and 0.25A at 24V
LCD glass	TFT with 18 bit resolution
Viewable area	86.40 mm (3.40 in) x 115.20 mm (4.54 in)
IP rating	IP 67
Operating temperature	-20° C to +60° C (-4° F to +140° F)
Storage temperature	-30° C to +80° C (-22° F to +176° F)
Weight	0.6 kg (1.3 lb)
Vibration	3.17 g
Shock	50 g
EMC	100 V/m
ESD	15 kV

Ordering information

Model features and product part numbers

A	B	C	D	E	F	G	Part number
DP570	01	00	00	00	00	01	11134525
DP570	01	00	00	00	01	01	11130432
DP570	01	00	00	00	00	00	11140997
DP570	01	00	00	00	01	00	11140996

Model features	Code	Description
A Model name	DP570	PLUS+ [®] Mobile Machine Displays
B Input / output options	01	User configurable 1 CAN, 2 DIN/AIN, 2 DIN/AIN/4-20 mA, 2 Multi-function, 1 DOUT 2 CAN, 2 DIN/AIN/4-20 mA, 2 Multi-function, 1 DOUT
C Real time clock	00	RTC
D Flash memory / application key	00	512 MB/without application key
E Application log (vault memory)	00	16 MB
F Video input options	00	None
G Mounting options	01	One video input
	00	Post mount cover
	01	Panel mounting

Related product	Part number
Panel mounting kit	11140430
DEUTSCH 12 pin mating connector kit 20 AWG	10100944
DEUTSCH 12 pin mating connector kit 16 to 22 AWG	10102025
Connection kit with camera cable	11145163
Post mounting kit	11144122



ENGINEERING
TOMORROW

Archivierung: 01/2021

Danfoss can accept no responsibility for possible errors in catalogues, brochures and other printed material. Danfoss reserves the right to alter its products without notice. This also applies to products already on order provided that such alterations can be made without changes being necessary in specifications already agreed.
All trademarks in this material are property of the respective companies. Danfoss and the Danfoss logotype are trademarks of Danfoss A/S. All rights reserved.

4 | © Danfoss | October 2017

L1317788 | A100000177en-US0604