

HYDAC INTERNATIONAL



Bladder Accumulators Standard design

1. DESCRIPTION

1.1. FUNCTION

Fluids are practically incompressible and cannot therefore store pressure energy. The compressibility of a gas is utilised in hydraulic accumulators for storing fluids. HYDAC bladder accumulators are based on this principle, using nitrogen as the compressible medium.

A bladder accumulator consists of a fluid section and a gas section with the bladder acting as the gas-tight separation element. The fluid around the bladder is connected to the hydraulic circuit so that the bladder accumulator draws in fluid when the pressure increases and the gas is compressed.

When the pressure drops, the compressed gas expands and forces the stored fluid into the circuit.

HYDAC bladder accumulators can be used in a wide variety of applications, some of which are listed below:

- Energy storage
 - Emergency operation
 - Force equilibrium
 - Leakage compensation
 - Volume compensation
 - Shock absorption
 - Vehicle suspension
 - Pulsation damping
- See catalogue section:
● Hydraulic dampers
No. 3.701

1.2. DESIGN

SB330/400/500/550/600, SB330H/SB330N

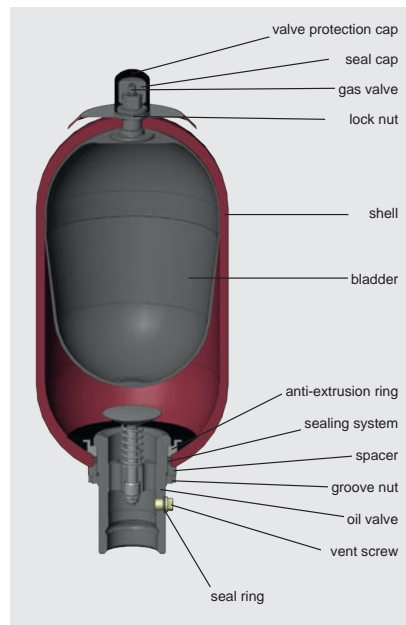

Design

● Standard bladder accumulator SB330/400/500/550

HYDAC standard bladder accumulators consist of the pressure vessel, the flexible bladder with gas valve and the hydraulic connection with check valve. The pressure vessels are seamless and manufactured from high tensile steel.

● Bladder accumulator SB330N

The flow-optimised design of the standard oil valve enables the maximum possible operating fluid flow rate to increase to 25 l/s with this accumulator type.

● High flow bladder accumulator SB330H

HYDAC high flow bladder accumulators type SB330 are high performance accumulators with a flow rate of up to 30 l/s. The fluid port is enlarged to allow higher flow rates.

● SB600

For higher pressures, with the ASME U stamp, HYDAC provides the series SB600 with approval S (p_{max} 345 bar / 5000 psi).

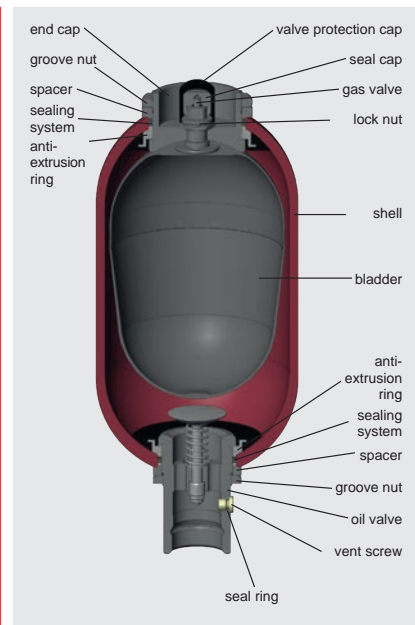

Design

● Bladder accumulator SB330B

HYDAC bladder accumulators SB330B are designed to allow the bladder to be removed from above. This has the advantage that the bladder accumulator does not need to be removed from the hydraulic system for inspection and repair work.



1.3. BLADDER MATERIAL

The bladder material must be selected in accordance with the particular operating medium or operating temperature, see section 2.1.

If discharge conditions are unfavourable (high p_2/p_0 pressure ratio, rapid discharge speed), the gas may cool to below the permitted temperature. This can cause cold cracking. The gas temperature can be calculated using the HYDAC Accumulator Simulation Program **ASP**.

1.4. CORROSION PROTECTION

For operation with chemically aggressive media, the accumulator shell can be supplied with corrosion protection, such as chemical nickel-plating. If this is insufficient, then stainless steel hydraulic accumulators must be used.

1.5. INSTALLATION POSITION

HYDAC bladder accumulators can be installed vertically, horizontally and at a slant. When installing vertically or at a slant, the oil valve must be at the bottom. For certain applications listed below, particular positions are preferable:

- Energy storage: vertical
- Pulsation damping: any position from horizontal to vertical
- Maintaining constant pressure: any position from horizontal to vertical
- Volume compensation: vertical

If the installation position is horizontal or at a slant, the effective fluid volume and the maximum permitted flow rate of the operating fluid are reduced.

1.6. TYPE OF INSTALLATION

By using an adapter, HYDAC hydraulic accumulators with a volume of up to 1 l can be installed directly inline.

For strong vibrations and volumes above 1 litre, we recommend the use of HYDAC mounting clamps or the HYDAC accumulator mounting set.

See catalogue sections:

- Mounting elements for hydraulic accumulators No. 3.502
- ACCUSET SB No. 3.503

2. SPECIFICATIONS

2.1. EXPLANATIONS, NOTES

2.1.1 Operating pressure

See tables in section 3. (PED)
May differ from nominal pressure for other test certificates.

2.1.2 Permitted operating temperature of the hydraulic accumulator

-10 °C ... +80 °C
Standard design, others on request

2.1.3 Nominal volume

See tables in section 3.

2.1.4 Effective gas volume

See tables in section 3.
Based on nominal dimensions, this differs slightly from the nominal volume and must be used when calculating the effective fluid volume.

2.1.5 Effective volume

Volume of fluid which is available between the operating pressures p_2 and p_1 .

2.1.6 Max. flow rate of the operating fluid

In order to achieve the max. flow rate given in the tables, the accumulator must be installed vertically. It must be noted that a residual fluid volume of approx. 10 % of the effective gas volume remains in the accumulator.

The maximum fluid flow rate was determined under specific conditions and is not applicable in all operating conditions.

2.1.7 Working temperature and operating medium

The permitted working temperature of a bladder accumulator is dependent on the application limits of the metal materials and the bladder. Outside this temperature range, special materials must be used. The operating medium must also be taken into account. The following table displays a selection of elastomer materials including max. temperature range and a rough overview of resistant and non-resistant fluids. Please contact us for help in selecting a suitable elastomer.

Materials		Material code ¹⁾	Temperature range	Overview of the fluids ²⁾	
				Resistant to	Not resistant to
NBR	Acrylonitrile butadiene rubber	2	-15 °C ... + 80 °C	<ul style="list-style-type: none"> ● Mineral oil (HL, HLP) ● Flame-retardant fluids from the groups HFA, HFB, HFC ● Synthetic esters (HEES) ● Water ● Sea water 	<ul style="list-style-type: none"> ● Aromatic hydrocarbons ● Chlorinated hydrocarbons (HFD-S) ● Amines and ketones ● Hydraulic fluids from the group HFD-R ● Fuels
		5	-50 °C ... + 50 °C		
		9	-30 °C ... + 80 °C		
ECO	Ethylene oxide epichlorohydrin rubber	3	-30 °C ... +120 °C	<ul style="list-style-type: none"> ● Mineral oil (HL, HLP) ● Flame-retardant fluids from the HFB group ● Synthetic esters (HEES) ● Water ● Sea water 	<ul style="list-style-type: none"> ● Aromatic hydrocarbons ● Chlorinated hydrocarbons (HFD-S) ● Amines and ketones ● Hydraulic fluids from the group HFD-R ● Flame-retardant fluids from the groups HFA and HFC ● Fuels
IIR	Butyl rubber	4	-50 °C ... +100 °C	<ul style="list-style-type: none"> ● Hydraulic fluids from the group HFD-R ● Flame-retardant fluids from the group HFC ● Water 	<ul style="list-style-type: none"> ● Mineral oils and mineral greases ● Synthetic esters (HEES) ● Aliphatic, chlorinated and aromatic hydrocarbons ● Fuels
FKM	Fluorine rubber	6	-10 °C ... +150 °C	<ul style="list-style-type: none"> ● Mineral oil (HL, HLP) ● Hydraulic fluids from the group HFD ● Synthetic esters (HEES) ● Fuels ● Aromatic hydrocarbons ● Inorganic acids 	<ul style="list-style-type: none"> ● Amines and ketones ● Ammonia ● Skydrol and HyJet IV ● Steam

¹⁾ See section 2.2. Model code, material code, accumulator bladder

²⁾ Others on request



2.1.8 Gas charging

Hydraulic accumulators must only be charged with nitrogen. Never use other gases.

Risk of explosion!

In principle, only use nitrogen of at least Class 4.0 (filtration < 3 µm).

If other gases are to be used, please contact HYDAC for advice.

2.1.9 Limits for gas pre-charge pressure

$$p_0 \leq 0.9 \cdot p_1$$

with a permitted pressure ratio of:

$$p_2 : p_0 \leq 4 : 1$$

p_2 = max. operating pressure

p_0 = pre-charge pressure

The specified values are maximum values and must not be considered as referring to a permanent load. The tolerable pressure ratio is influenced by the geometry, temperature, fluid and flow rate as well as any gas losses due to physical properties.

2.1.10 Certificate codes

Country	Certificate code (CC)
EU member states	U
Australia	F ¹⁾
Belarus	A6
Canada	S1 ¹⁾
China	A9
Hong Kong	A9
Iceland	U
Japan	P
Korea (Republic)	A11
New Zealand	T
Norway	U
Russia	A6
South Africa	S2
Switzerland	U
Turkey	U
Ukraine	A10
USA	S

¹⁾ = Registration required in the individual territories or provinces.

Others on request

2.1.11 Gas-side connection, standard model

Series	Volume [l]	Gas valve type
SB330 / SB400	< 1	5/8-18UNF
	< 50	7/8-14UNF
SB500 / SB600	≥ 50	M50x1.5 / 7/8-14UNF
	10 ... 50	M50x1.5 / 7/8-14UNF
SB550	1 ... 5	7/8-14UNF

Other pressure ranges on request

2.1.12 Notice

All work on HYDAC bladder accumulators must only be carried out by suitably trained staff.

Incorrect installation or handling can lead to serious accidents.

The operating instructions must be observed!

No. 3.201.BA

Assembly and repair instructions are available for work which may be carried out on the bladder accumulator after installation and commissioning, e.g. repair work.

No. 3.201.M

Further information such as accumulator sizing, safety information and extracts from the acceptance specifications can be found in the following catalogue section:

- HYDAC Accumulator Technology No. 3.000

Relevant PDF documents can be accessed at:

www.hydac.com » Downloads » Documents » Accumulator Division



2.2. MODEL CODE

Not all combinations are possible. Order example.
For further information, please contact HYDAC.

SB330 (H) - 32 A 1 / 112 U - 330 A 050

Series

Type code

No details = standard

H = high flow

N = flow-optimised valve, fluid side

A = shock absorber

P = pulsation damper ³⁾

B = bladder top-repairable

E = bladder with foam filling

DA = bladder integrity system, industry version

(others on request)

L = light-weight

Combinations must be agreed with HYDAC.

Nominal volume [l]

Fluid port

A = standard connection, thread with internal seal face

F = flange connection

C = valve mounting with screws on underside

E = sealing surfaces on front interface

(e.g. on thread M50x1.5 - valve)

G = external thread

S = special connection, to customer specification

Gas side

1 = standard design (see section 2.1.11)

2 = back-up version ⁴⁾

3 = gas valve 7/8-14UNF with M8 internal thread

4 = gas valve 7/8-14UNF with gas valve connection 5/8-18UNF

5 = gas valve M50x1.5 in accumulators smaller than 50 l

6 = 7/8-14UNF gas valve

7 = M28x1.5 gas valve

8 = M16x1.5 gas valve

(with M14x1.5 bore in gas valve)

9 = special gas valve, to customer specification

Material code (MC)

dependent on operating medium

standard design = 112 for mineral oils

others on request

Fluid port

1 = carbon steel

2 = high tensile steel

3 = stainless steel ²⁾

6 = low temperature steel

Accumulator shell

0 = plastic coated (internally)

1 = carbon steel

2 = chemically nickel-plated (internal coating)

4 = stainless steel ²⁾

6 = low temperature steel

Accumulator bladder ¹⁾

2 = NBR ⁵⁾

3 = ECO

4 = IIR

5 = NBR ⁵⁾

6 = FKM

7 = other

9 = NBR ⁵⁾

Certification code

U = European Pressure Equipment Directive (PED)

Permitted operating pressure [bar]

Connection, fluid side

Thread, codes for fluid port: A, C, E, G

A = thread to ISO228 (BSP)

B = thread to DIN13 or ISO965/1 (metric)

C = thread to ANSI B1.1 (UN...-2B seal SAE J 514)

D = thread to ANSI B1.20.1 (NPT)

S = special thread, to customer specification

Flange, codes for fluid port: F

A = EN 1092-1 welding neck flange

B = flange ASME B16.5

C = SAE flange 3000 psi

D = SAE flange 6000 psi

S = special flange, to customer specification

Pre-charge pressure p_0 (bar) at 20 °C, must be stated clearly, if required!

¹⁾ When ordering a spare bladder, please state diameter of the smaller shell port

²⁾ Dependent on type and pressure rating

³⁾ See catalogue section Hydraulic dampers, No. 3.701

⁴⁾ See catalogue section Hydraulic accumulators with back-up nitrogen bottles, No. 3.553

⁵⁾ Observe temperature ranges, see section 2.1.

3. DIMENSIONS AND SPARE PARTS

3.1. DIMENSIONS

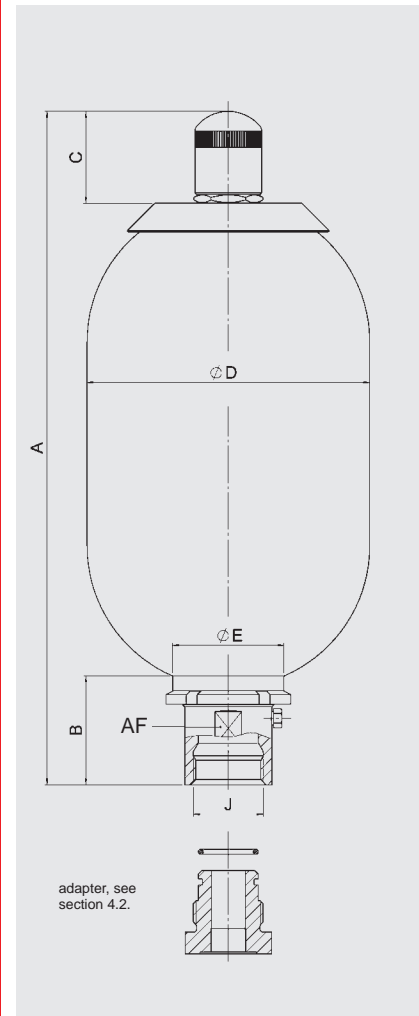

Carbon steel, NBR

Nominal volume	Series	Max. operating pressure				Eff. gas volume	A max.	B	C	Ø D max.	J thread	Ø E	AF	Q ¹⁾	Weight	
		Certificate code (CC) U		Certificate code (CC) S												
[l]		[bar]	Part no.	[bar]	Part no.	[l]	[mm]	[mm]	[mm]	[mm]	ISO 228	[mm]	[mm]	[l/s]	[kg]	
0.5	SB400	400	3047163	–	–	0.5	270	57	33.5	96	G 3/4	50	32	4	4	
1	SB330	330	3047162	–	–	1	316	57	56	115	G 3/4	50	32	4	7	
	SB550 ³⁾	550	3110531	–	–		343	67		123	G 1	67	45	6	10	
2.5	SB330	330	3047165	–	–	2.4	528	64	56	115	G 1 1/4	67	50	10	11	
	SB550 ³⁾	550	3068916	–	–	2.5	550	67		123	G 1		45	6	14	
4	SB330	330	3047166	–	–	3.7	412	65	56	170	G 1 1/4	67	50	10	15	
	SB400 ³⁾	400	3107905	–	–											
5	SB550 ³⁾	550	3090654	–	–	4.9	876	64	56	123	G 1	67	45	6	17	
6	SB330	330	3047168	–	–	5.7	534	65	56	170	G 1 1/4	67	50	10	18	
10 ²⁾	SB330	330	3047170	–	–	9.3	810	65	56	170	G 1 1/4	67	50	10	31	
10	SB330	330	3047172	262	3141237	9.3	582	101	56	229	G 2	100	70	15	33	
	SB330N		3156632	–	–									25	34	
	SB330H		3079081	–	–									30	38	
	SB400 ³⁾	400	3107393	–	–	9.3	578	136		234	41					
	SB500 ³⁾	500	3130252	–	–	8.8	598	101		69	241	G 2	100	70	15	46
	SB600	–	–	345	332265											
13	SB330	330	3047173	–	–	12	695	101	56	229	G 2	100	70	15	46	
	SB330N		–	–	–									–	25	47
	SB330H		–	–	–									–	30	45
	SB400 ³⁾		400	–	–									–	695	101
20	SB330	330	3047174	262	3117153	18.4	895	101	56	229	G 2	100	70	15	49	
	SB330N		3162982	–	–									25		
	SB330H		3092659	–	–									17.5	930	136
	SB400 ³⁾	400	3115007	–	–	18.4	895	101		69	241	G 2	100	70	15	71
	SB500 ³⁾	500	3118156	–	–	17	913	101		69	241	G 2	100	75	15	77
	SB600	–	–	345	332266											
24	SB330	330	3047175	–	–	23.6	1060	101	56	229	G 2	100	70	15	72	
	SB330N		–	–	–									–	25	73
	SB330H		–	–	–									–	24	1095
32	SB330	330	3047176	262	3117154	33.9	1410	101	56	229	G 2	100	70	15	80	
	SB330N		3220899	–	–									25	81	
	SB330H		3059515	–	–									32.5	1445	136
	SB400 ³⁾	400	3125141	290	–	33.9	1410	101		69	241	G 2	100	70	15	104
	SB500 ³⁾	500	3760577	–	–	33.5	1423	101		69	241	G 2	100	75	15	112
	SB600	–	–	345	332267											
50	SB330	330	3047177	262	362904	47.5	1933	101	69	229	G 2	100	70	15	114	
	SB330N		3185604	–	–									25	115	
	SB330H		3089605	–	–									1968	136	234
	SB400 ³⁾	400	3114662	–	–	48.3	1933	101		69	241	G 2	100	75	15	167
	SB500 ³⁾	500	3130253	–	–											
	SB600	–	–	345	332268											
60	SB330	330	3341217	–	–	60	1210	138	69	360	G 2 1/2	125	90	30	160	
80	SB330	330	–	–	–	85	1460	138	69	360	G 2 1/2	125	90	30	200	
100	SB330	330	3098489	–	–	105	1710	138	69	360	G 2 1/2	125	90	30	234	
130	SB330	330	–	–	–	133	2030	138	69	360	G 2 1/2	125	90	30	283	
160	SB330	330	–	–	–	170	2059	137	69	410	G 2 1/2	125	90	30	345	
200	SB330	330	–	–	–	201	2359	137	69	410	G 2 1/2	125	90	30	403	

¹⁾ Q = max. flow rate of the operating fluid under optimum conditions

²⁾ Slimline version, for confined installation spaces

³⁾ Material code (MC) = 212 for certificate code (CC) U, see model code, section 2.2.

3.2. SPARE PARTS

SB330/400/500/550/600
 SB330H / SB330N

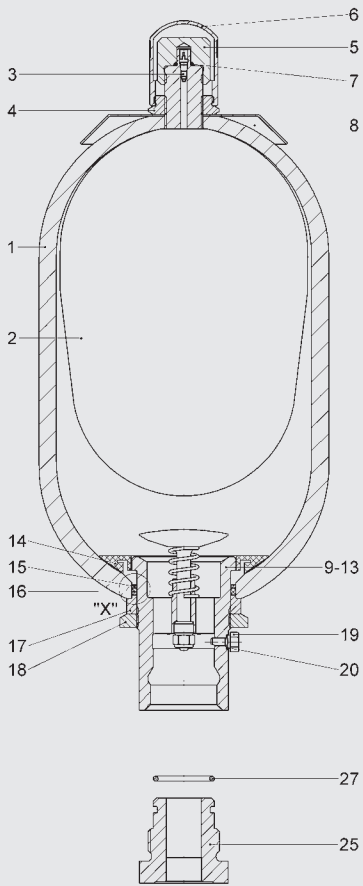

Detail "X"

SB330/400 – 0.5 ... 6 l
 SB330 – 10 l slimline version

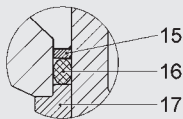

SB330/400/500/600 – 10 ... 50 l
 SB330 - 60 ... 200 l
 SB330H/N – 10 ... 50 l
 SB550 – 1 ... 5 l

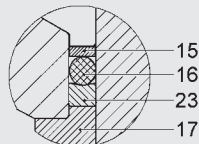

Description	Item
-------------	------

Bladder assembly¹⁾
 consisting of:

Bladder	2
Gas valve insert*	3
Lock nut	4
Seal cap	5
Protective cap	6
O-ring	7

Seal kit
 consisting of:

O-ring	7
Washer	15
O-ring	16
Vent screw	19
Support ring	23
O-ring	27

Repair kit¹⁾
 consisting of:

Bladder assembly (see above)	
Seal kit (see above)	

Oil valve assembly

consisting of:	
Valve	9-13
Anti-extrusion ring*	14
Washer	15
O-ring	16
Spacer	17
Groove nut	18
Vent screw	19
Support ring	23

* Available separately

¹⁾ When ordering, please state diameter of the smaller shell port

Accumulator shell (item 1) and company label (item 8) not available as a spare part

Vent screw (item 19) for NBR/carbon steel: seal ring (item 20) included

Adapter (item 25) incl. O-ring (item 27) available as an accessory, section 4.

SB330/400
 carbon steel, NBR
 standard gas valve

Volume [l]	Bladder assembly	Seal kit	Repair kit
0.5	365263	353606	2128169 ²⁾
1	237624		2106261
2.5	236171	353609	2106200
4	236046		2106204
5	240917		2106208
6	2112097		2112100
10*	2127255 ¹⁾		3117512 ¹⁾
10	236088	353621	2106212
13	376249		2106216
20	236089		2106220
24	376253		2106224
32	235335		2106228
50	235290		2106252
60	3364274	3102043 ¹⁾	3117513
80	3364312		3117514
100	3127313		3117515
130	3201384		3117516
160	3184769		3117517
200	3461300		3117558

Volume [l]	Oil valve assembly	Anti-extrusion ring	Gas valve insert	
0.5	2102355	2105411	632865	
1				
2.5				2105431
4				2105451
5				2105431
6	238523	2105451		
10*				
10	352572	2105491		
13				
20				
24				
32				
50				
60	3273734	3102326		
80				
100				
130				
160				
200				

* Slimline version, for confined installation spaces

¹⁾ Only for SB330

²⁾ Only for SB400

Others on request

4. ACCESSORIES FOR BLADDER ACCUMULATORS

4.1. ADAPTERS (GAS SIDE)

The adapters shown below are available for standard connections on bladder accumulators and must be specified separately in the order.

4.1.1 Adapter for safety devices

Adapter for connecting safety devices, such as burst discs or temperature fuses, see catalogue section:

- Safety equipment for hydraulic accumulators
No. 3.552

4.1.2 Pressure gauge model

Gas-side connection on the bladder accumulator for permanent monitoring of the pre-charge pressure

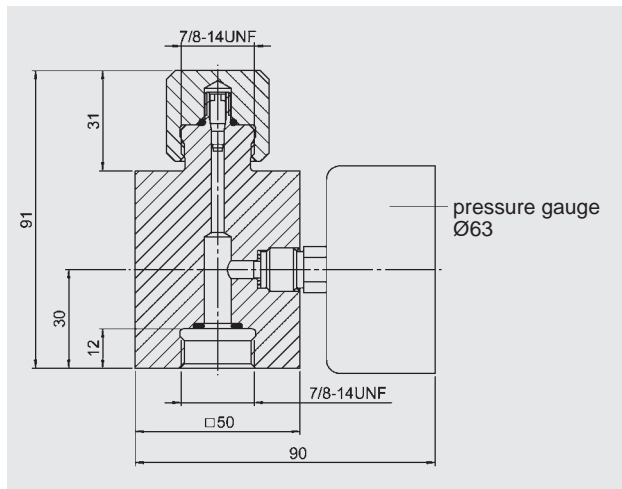

Gauge indication range	Pressure gauge Part no.	Adapter* assembly Part no.
–	–	366621
0 - 10 bar	614420	2108416
0 - 60 bar	606886	3093386
0 - 100 bar	606887	2104778
0 - 160 bar	606888	3032348
0 - 250 bar	606889	2100217
0 - 400 bar	606890	2102117

* p_{max} = 400 bar

4.1.3 Pressure gauge model with shut-off valve

Gas side connection on the bladder accumulator for permanent monitoring of the pre-charge pressure with shut-off option.

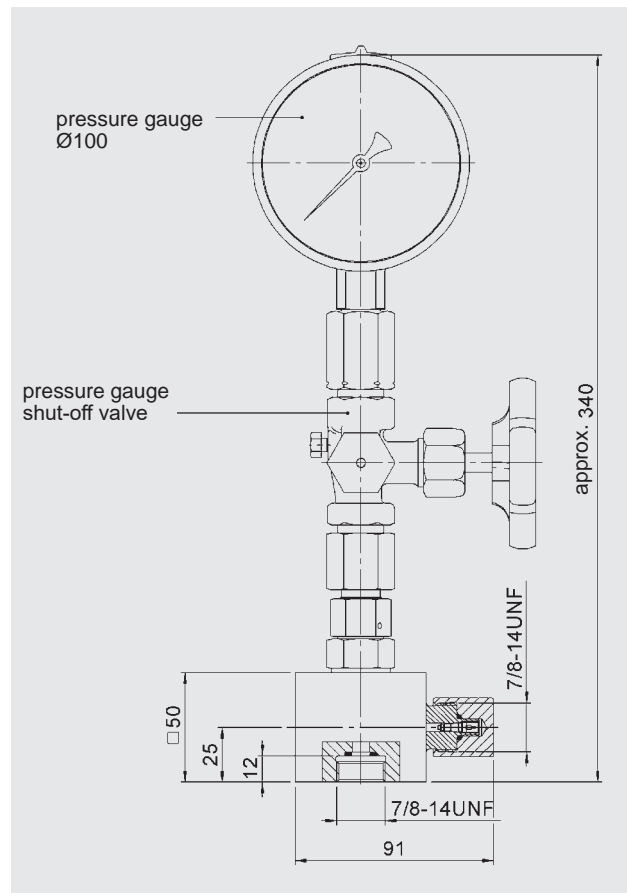

Gauge indication range	Pressure gauge Part no.	Adapter* assembly Part no.
–	–	2103381
0 - bar	617928	3784725
0 - 60 bar	606771	2110059
0 - 100 bar	606772	3139314
0 - 160 bar	606773	3202970
0 - 250 bar	606774	3194154
0 - 400 bar	606775	2103226

* p_{max} = 400 bar

4.1.4 Remote monitoring of the pre-charge pressure

To monitor the pre-charge pressure in hydraulic accumulators remotely, gas-side adapters with a pressure gauge and mounting bores are available.

In order to connect these adapters directly to the hydraulic accumulator using appropriate pipework, accumulator connectors are also available for connection at the top (see figure 1) or for connection at the side (see figure 2).

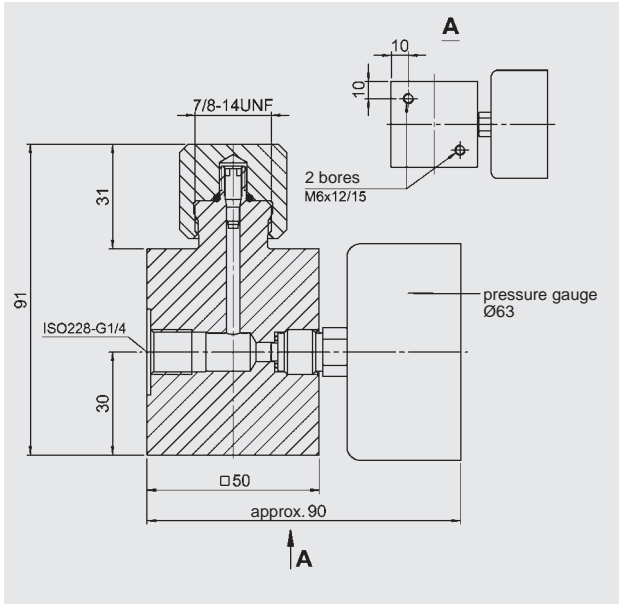

Gauge indication range	Pressure gauge Part no.	Adapter* assembly Part no.
-	-	3037666
0 - 10 bar	614420	3095818
0 - 60 bar	606886	3095819
0 - 100 bar	606887	3095820
0 - 160 bar	606888	3095821
0 - 250 bar	606889	3095822
0 - 400 bar	606890	3095823

* p_{max} = 400 bar

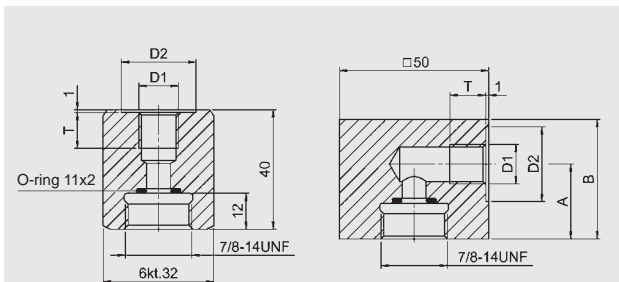

Figure 1

Figure 2

D1 Threaded connection	D2 [mm]	T [mm]	A [mm]	B [mm]	Adapter* assembly Part no.	Figure
ISO228 - G 1/4	25	14	-	-	2109481	1
			25	40	2102042	2
ISO228 - G 3/8	28	14	-	-	2109483	1
			25	40	366607	2
ISO228 - G 1/2	34	16	-	-	2110636	1
			31	55	366608	2

* p_{max} = 400 bar

4.2. ADAPTERS FOR STANDARD BLADDER ACCUMULATORS (FLUID SIDE)

To connect the bladder accumulator to threaded pipe fittings. These are available separately.

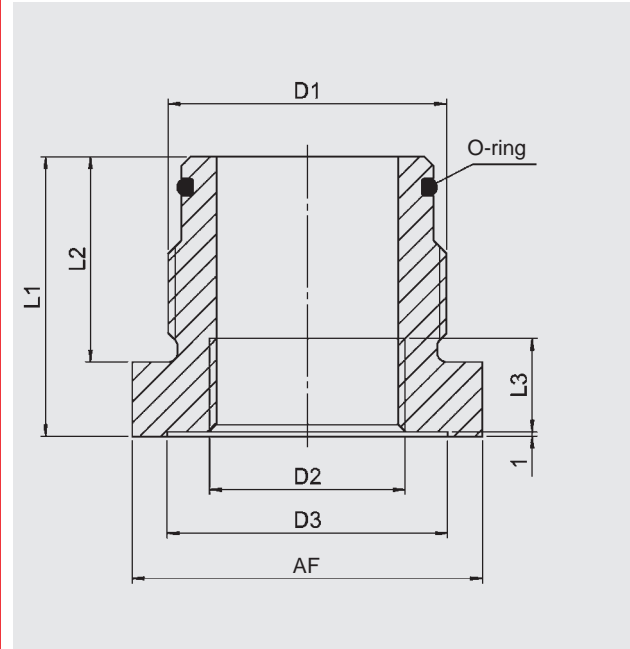

D1 Accum. conn.*	D2	D3 [mm]	L1 [mm]	L2 [mm]	L3 [mm]	AF [mm]	O-ring [mm]	Part no.
ISO 228-BSP G 3/4	ISO 228-BSP G 3/8	28	55	28	12	32	17x3	2104346
	ISO 228-BSP G 1/2				14	36		2104348
G 1 1/4	G 3/8	34	50	37	12	46	30x3	2116345
	G 1/2				14			2105232
	G 3/4	16	2104384					
G 2	G 1	50	67	44	18	65	48x3	2110124
	G 1/2				14	2104853		
	G 3/4	16			2104849			
	G 1	18			2124831			
	G 1 1/4	20			2107113			
G 2 1/2	G 1 1/2	68	80	22	70	62x4	2105905	
	G 1 1/4				20		2127406	
	G 2	22			80		3243831	
G 2	G 1 1/2	96	88	27	100	62x4	2113403	
	G 2				27		2113403	

* Others on request

4.3. TRANSPORT EQUIPMENT FOR BLADDER ACCUMULATORS

Various types of transport equipment are available for transporting standard bladder accumulators. The weights of the bladder accumulators are given in section 3.1.

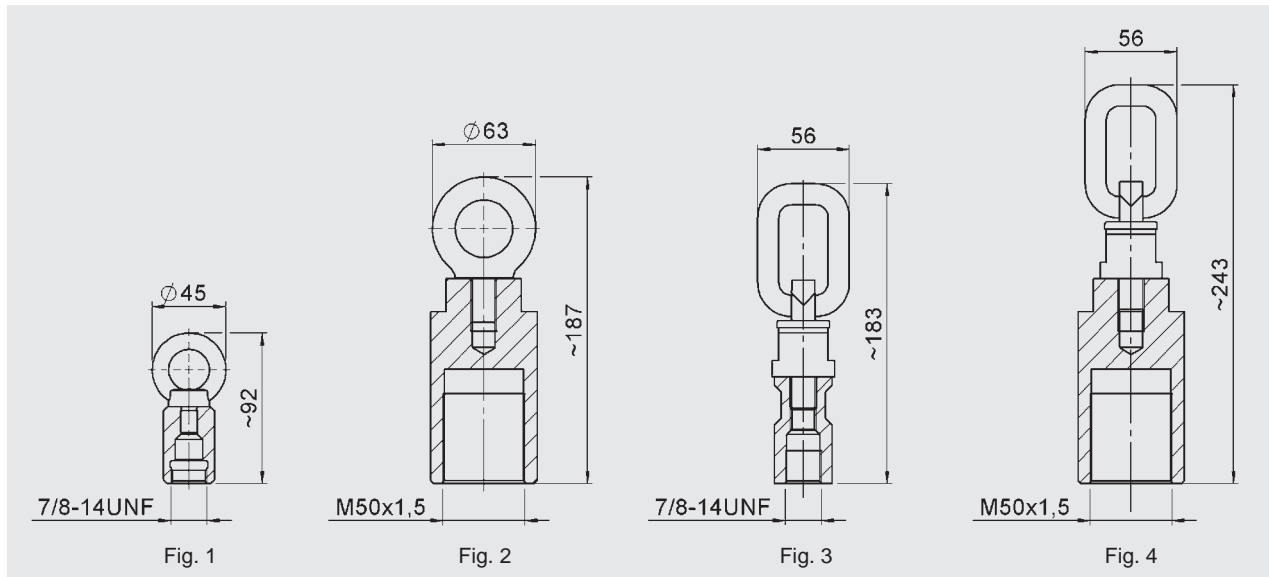

Material	Part no.	Gas side connection	max. [kg]	Special feature	Fig.
Carbon steel	4356969	7/8-14UNF	350	-	1
	4356971	M50x1.5	350	-	2
	4152199	7/8-14UNF	1120	swivel-type	3
	4356954	M50x1.5	1120	swivel-type	4

Others on request

5. NOTE

The information in this brochure relates to the operating conditions and fields of application described. For applications and/or operating conditions not described, please contact the relevant technical department. Subject to technical modifications.

HYDAC Technology GmbH
 Industriegebiet
66280 Sulzbach/Saar, Germany
 Tel.: 0049 (0) 68 97 / 509 - 01
 Fax: 0049 (0) 68 97 / 509 - 464
 Internet: www.hydac.com
 E-mail: speichertechnik@hydac.com

EN 3.201.31/04.21

