

Manatrol throttle check valves of series F with fine adjustment of the flow rate for a defined flow direction. The built-in check valve allows free flow in the counter direction with low flow resistance. A 2-stage needle provides very exact setting of smaller flow rates with the first three rotations of the adjustment knob. After 3 more rotations, the valve is completely open. The valve setting can be locked with the locking screw.

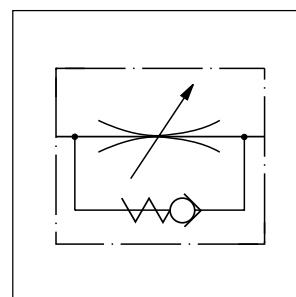

$$\text{Flow rate } Q \text{ [l/min]} = K_v \cdot \sqrt{\frac{\Delta p}{\gamma}}$$

K_v from the table
 Δp [bar]
 γ [kg/dm³] = specific weight of the medium
 (γ for mineral oil = 0.85 - 0.9)

Specifications

Return check poppet	0.4 bar
Nominal cracking pressure	
Operating temperature	-40 °C to +121 °C

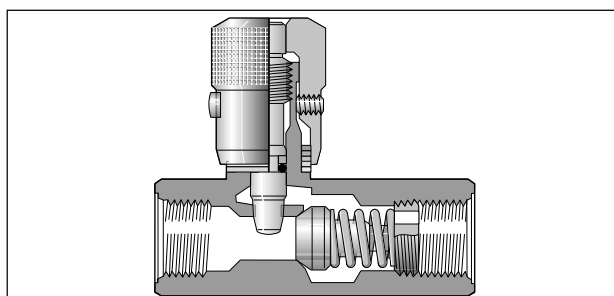
Ordering code

	F					
Thread type	Throttle check valve	Thread size	Body	Needle	Clamping screw	Seal

Code	Thread					Code	Seal
omit	NPTF					omit	NBR
9 ¹⁾	BSP					V	FPM

Code	Size					Code	Clamping screw
200	1/8					omit	Hexagon socket
400	1/4					F	With knurled knob
600	3/8					T	Tamper-proof
800	1/2						
1200	3/4						
1600	1						
2000	1 1/4						
2400	1 1/2						
3200	2						

Code	Needle
omit	Standard 2-stage needle
4 ³⁾	Micro-fine hollow needle with slot

Code	Body
S	Steel
B ²⁾	Brass

Bold letters = Short-term availability

¹⁾ Not for size 3200.
²⁾ Only for sizes 200 to 1600.
³⁾ Only for sizes 200 to 600.

Technical data

Size	Pressure [bar]		Max. flow [l/min Δp10bar]	Throttle surface [cm ²]	Throttle v. open Kv factor	Weight [kg]	
	Steel	Brass				Steel	Brass
200	350	140	11	0.066	3.3	0.13	0.13
400	350	140	25	0.13	6.3	0.23	0.23
600	350	140	40	0.22	11.2	0.31	0.31
800	350	140	50	0.28	14	0.67	0.68
1200	210	140	120	0.70	35.4	1.17	1.18
1600	210	35	250	1.48	75	2.31	2.32
2000	210	–	250	1.48	75	3.67	–
2400	210	–	250	1.48	75	4.62	–
3200	210	–	250	1.48	75	7.78	–

F-9F UK.indd CM 31.07.17

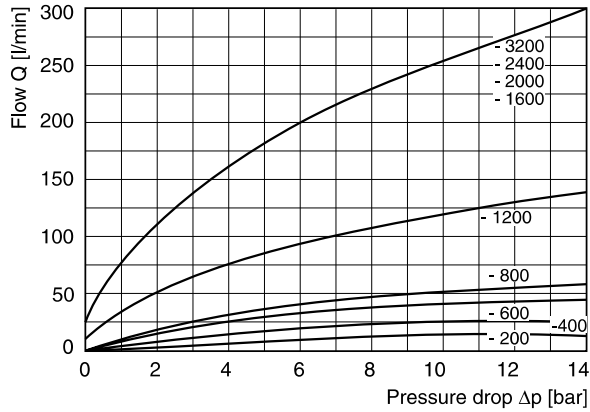
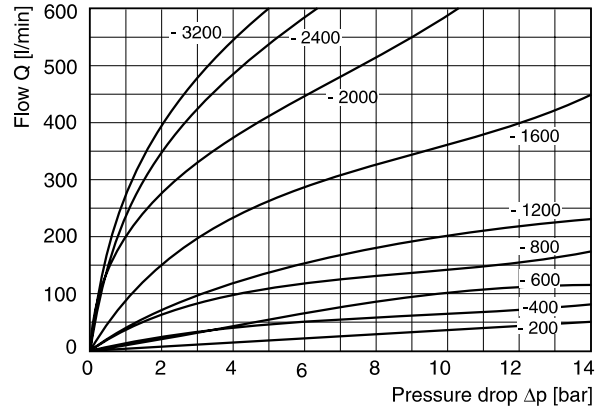
Controlled flow vs. pressure drop needle fully open

Free flow vs. pressure drop needle fully open

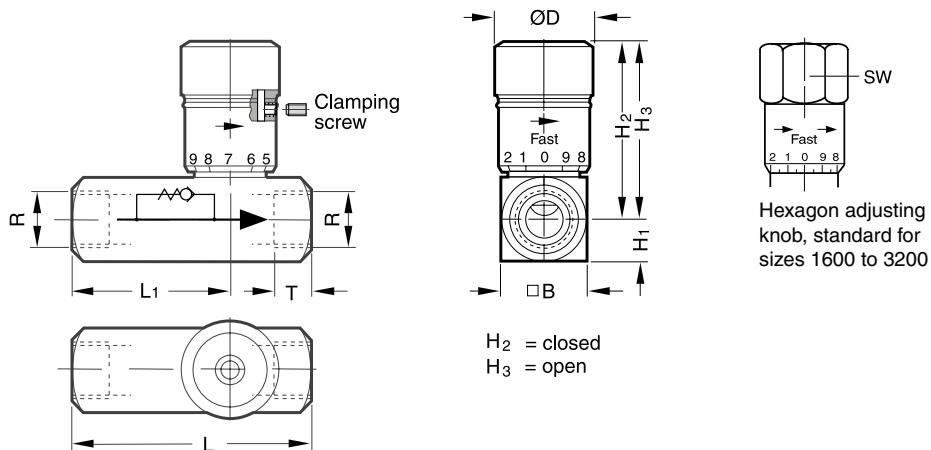
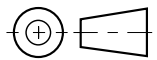
All characteristic curves measured with HLP46 at 50 °C.

Dimensions

10

Size	R*	H3	H2	H1	B	L1	L	ØD	SW	T
200	1/8	39	35	8	16	36	51	19	-	9
400	1/4	46	40	10.5	21	43	67	21	-	13
600	3/8	55	49	13	26	45	70	25	-	13
800	1/2	69	61	16	32	57	87	30	-	16
1200	3/4	86	71	19	38	65	99	35	-	17
1600	1	124	107	22.5	45	83	127	-	47.8	20
2000	1 1/4	130	114	29	58	99	143	-	-	21.5
2400	1 1/2	137	120	35	70	114	143	-	-	23.5
3200	2	146	130	44.5	89	134	165	-	-	25

* Pipe thread G or NPTF