

## Flow Divider

### Bi-directional Series MTDA



- robust, simple and reliable
- easy to service
- flows can be split or merged with accuracy (divide/combine functions).
- the flow division ratio can be altered to suit customer requirements.

## 1 Description

### 1.1 General

Series MTDA units are flow dividing valves that operate automatically. They are intended for use with hydraulic fluids. They divide a flow, the total rate of which may be varied, up to 4 part-flows. When flow passes through a valve in the opposite direction, the part-flows are combined into one single flow (added). The dividing and combining functions are largely independent of the pressures of the divided flows and of the fluid viscosity.

In order for the valve to work properly, a continuous flow is required at all ports. For example, if one actuator is no longer able to move, then the other part-flow will also be restricted. If the actuators served by the flow divider operate at different pressures, then the pressure of the total flow entering the valve will correspond to the higher of the two actuator pressures. Large pressure differences may give rise to significant heat generation, which must be taken into consideration when designing the system.

### 1.2 Application examples

- Work access platforms
- Lifting platform
- Harvesters
- Municipal equipment
- Snow/ice clearing equipment
- Wood chippers
- Road rollers
- Tail lifts

## 2 Symbols

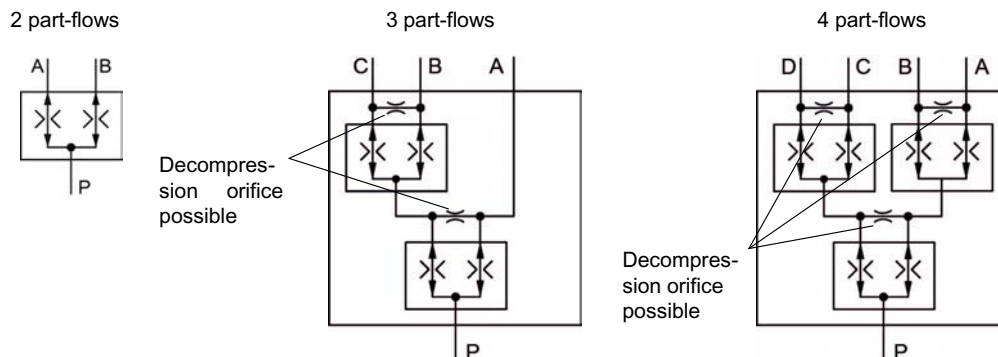

# BUCHER hydraulics

## 3 Technical data

General characteristics	Unit	Description, value
Maximum operating pressure	bar	315
Oil temperature range	°C	-20 ... +80
Viscosity range	mm <sup>2</sup> /s	10 ... 300
Maximum admissible level of contamination of the hydraulic fluid		ISO 4406 code 20/18/15
Nitrile seals		NBR (Nitril-Butadin-Kautschuk)
Weight:		
MTDA08	kg	1,5
MTDA16		8
MTDA..3F		8,3
MTDA..4F		8,4

## 4 Performance graph

Values refer to an viscosity of 35 mm<sup>2</sup>/s.

### 4.1 Division accuracy [%]

Division accuracy +/- 3% of the max. flow rate, based on control flow range of the respective flow divider (see chapter 6).

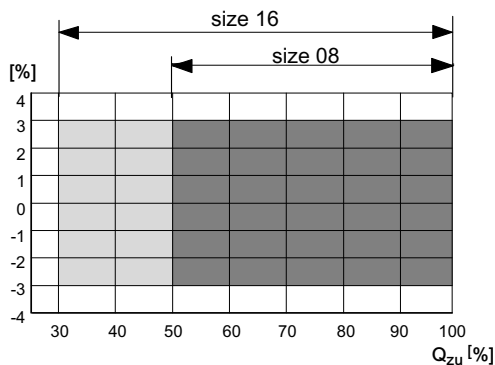

### 4.2 Pressure drop characteristics ( $\Delta p$ )

Pressure drop v. flow rate

#### 4.2.1 MTDA08 / MTDA16

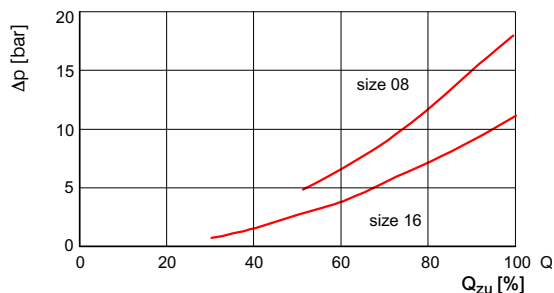

#### 4.2.2 MTDA..3F / MTDA..4F

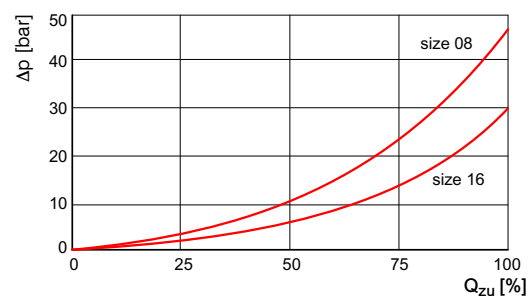

**IMPORTANT** :  $Q_{zu}$  = really inlet flow (0% = 0 l/min, 100% = maximum control flow)  
Higher division accuracy on enquiry.

## 5 Dimensions

### 5.1 MTDA08

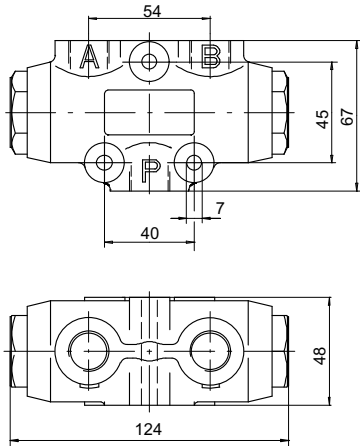

### 5.2 MTDA16

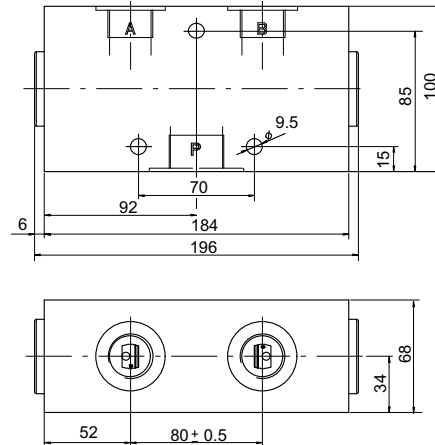

#### 5.2.1 Port threads

Flow range [l/min]	Metric		Inch	
	Port P	Port A + B	Port P	Port A + B
004 ... 025	M18 x 1,5	M18 x 1,5	G $\frac{3}{8}$ "	G $\frac{3}{8}$ "
032 ... 100	M22 x 1,5	M18 x 1,5	G $\frac{1}{2}$ "	G $\frac{3}{8}$ "
100 ... 120	M27 X 2	M22 x 1,5	G $\frac{3}{4}$ "	G $\frac{1}{2}$ "
160 ... 250	M33 x 2	M27 x 2	G1"	G $\frac{3}{4}$ "

### 5.3 MTD083F / MTD084F

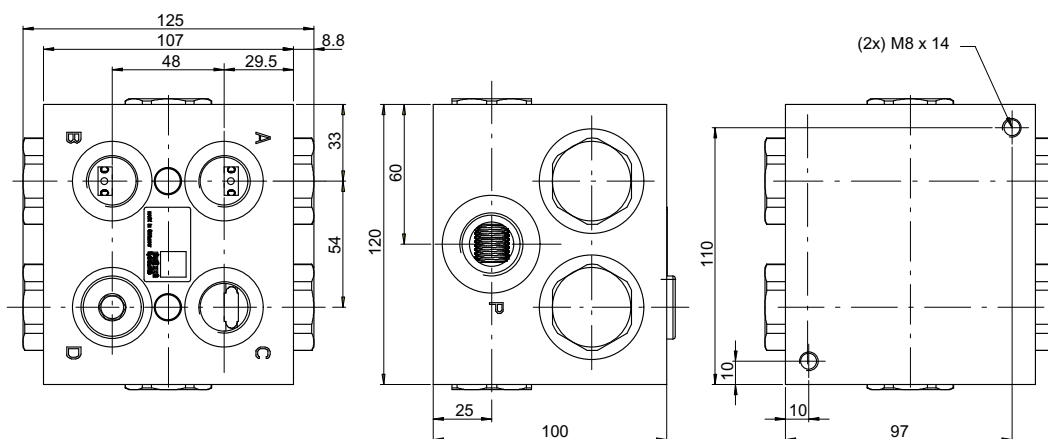

#### 5.3.1 Port threads

Flow range [l/min]	Metric		
	Port P	Port A+B	Port C+D
004 ... 100	M27 x 2	M22 x 1,5	M22 x 1,5





## **BUCHER** hydraulics

### **7 End-stop synchronisation of parallel-connected cylinders**

When one of the two cylinders reaches its end-stop, the flow to the other cylinder drops to approx. 5 - 10% of its nominal rate. This pressure-dependent leakage flow enables the other cylinder to slowly re-synchronise itself. To enable full-speed re-synchronisation of the lagging cylinder, each actuator line from the flow divider must be equipped with a pressure relief valve.

### **8 Installation attitude and mounting**

To prevent the weight of the spool causing division inaccuracies, the valve must be installed so that the spool axis is horizontal. When mounting the valve, make sure that the body is not subjected to any distorting forces. Do not use tapered-thread pipe fittings.

[info.kl@bucherhydraulics.com](mailto:info.kl@bucherhydraulics.com)

[www.bucherhydraulics.com](http://www.bucherhydraulics.com)

© 2020 by Bucher Hydraulics GmbH, D-79771 Klettgau

All rights reserved.

Data is provided for the purpose of product description only, and must not be construed as warranted characteristics in the legal sense. The information does not relieve users from the duty of conducting their own evaluations and tests. Because the products are subject to continual improvement, we reserve the right to amend the product specifications contained in this catalogue.

Classification: 430.310.335.310.