

HYDAC INTERNATIONAL

OffLine Filter OLF 5

Description

The OLF 5 and 10 series of filters are used for the offline, fine filtration of hydraulic oils. The series comprises numerous versions, for example with or without motor-pump unit, element removal from either top or bottom, in-tank mounting, with optional sensors for determining the cleanliness code and water content, etc. For every application therefore, HYDAC can provide the right unit. Depending on the model, flow rates up to 15 l/min and viscosities up to 7,000 mm²/s can be supported.

The Dimicron elements used are characterized by:

- particularly high contamination retention capacity
- environmentally safe disposal (incinerable) and
- water absorption (optional).

Applications

- Machine tools
- Plastic injection moulding machines
- Mobile hydraulics
- Industrial hydraulics
- Wind power

Advantages

- Improved component and system filter lifetime
- Greater machine availability
- Longer oil change intervals
- Minimum space requirement due to compact design
- Very easy maintenance
- High contamination retention capacity of the elements
- Option: Continuous monitoring of solid particle contamination and water saturation in the oil during cleaning
- Environmentally safe disposal of elements (incinerable)

Technical details

Pump type	Vane pump
Fluid temperature range	0 to 80 °C
Ambient temperature range	-20 to 40 °C
Seal material	NBR or FKM
Supply voltage / power consumption	Depending on version
Electrical protection class	IP 54

Preferred models (with shorter delivery times)

Part number	Model code
3073372	OLF-5-F-Z-Z-E
349565	OLF-5-S-120-N-Z-E
3655862	OLF-5/15-S-370-N-Z-E

Technical details

	OLF-5...	OLF-5/4...	OLF-5/15...	OLF-10/15...	OLF-5/Z...	OLF-10/Z...
Flow rate	5 l/min*	5 l/min*	15 l/min*	15 l/min*	15 l/min*	30 l/min*
Max. operating pressure	3.5 bar	4.5 bar	4.5 bar	4.5 bar	6.0 bar	6.0 bar
Viscosity range	15 to 150 mm ² /s	15 to 1000 mm ² /s*	15 to 1000 mm ² /s**	15 to 1000 mm ² /s**	15 to 1000 mm ² /s**	15 to 1000 mm ² /s**
Permitted pressure at INLET port						
OLF-x-S	-0.4 to 0.6 bar	-0.4 to 0.6 bar	-0.4 to 0.6 bar	-	-	-
OLF-x-E	10 to 50 bar	-	-	-	-	-
OLF-x-F	-0.4 to 6 bar	-	-	-	-	-
OLF-x-T	-	-	-0.4 to 0.6 bar	-0.4 to 0.6 bar	6 bar	6 bar
OLF-CM-x-T	-	-	-0.4 to 0.6 bar	-0.4 to 0.6 bar	-	-
Hydraulic connections according to ISO 228						
OLF-x-S	IN = 1/2" OUT = 3/8"	IN = 1" OUT = 1"	IN = 1" OUT = 1"	-	-	-
OLF-x-E	IN = " OUT = 1/2"	-	-	-	-	-
OLF-x-F	IN = 1/2" OUT = 1/2"	-	-	-	-	-
OLF-x-T	-	-	IN = 1" OUT = 1"	IN = 1" OUT = 1"	IN = 1/2" OUT = 1/2"	IN = 1" OUT = 1"
OLF-CM-x-T	-	-	IN = 1" OUT = 1"	IN = 1" OUT = 1"	-	-
Filtration rating						
Dimicron	2, 5, 10 or 20 µm	2, 5, 10 or 20 µm	2, 5, 10 or 20 µm	2, 5, 10 or 20 µm	2, 5, 10 or 20 µm	2, 5, 10 or 20 µm
Aquamicron	2 or 20 µm	2 or 20 µm	2 or 20 µm	2 µm	2 or 20 µm	2 µm
Contamination retention capacity to ISO 16889 Δp = 2.5 bar						
Dimicron	240 g	240 g	240 g	480 g	240 g	480 g
Aquamicron	185 g and ≈ 0.25 l water	185 g and ≈ 0.25 l water	185 g and ≈ 0.25 l water	370 g and ≈ 0.50 l water	185 g and ≈ 0.25 l water	370 g and ≈ 0.50 l water
Weight when empty						
OLF-x-S	≈ 9 kg	≈ 11 kg	≈ 12 kg	-	-	-
OLF-x-E	≈ 4 kg	-	-	-	-	-
OLF-x-F	≈ 4 kg	-	-	-	-	-
OLF-x-T	-	-	≈ 13 kg	≈ 15 kg	≈ 5 kg	≈ 6 kg
OLF-CM-x-T	-	-	≈ 16 kg	≈ 16 kg	-	-
Filter element type / size						
	N5	N5	N5	N10	N5	N10

* = When the viscosity is high, the flow rate can be significantly lower.

** = For basic type OLF-CM maximum 15 to 200 mm²/s

- = Model not available



Model code

OLF - 5 - S - 120-N - N5DM002 - E /-7.5

Basic type

- OLF = OffLine filter
- OLFCM = OffLine filter with FluidCondition Monitoring (only with size 5/15, 10/15 and Toploader version) (permitted viscosity range 5 to 200 mm²/s)

Size and nominal flow rate

- 5 = 5 l/min (not for Toploader version)
- 5/4 = 5 l/min (for lubrication systems)
- 5/15 = 15 l/min
- 10/15 = 15 l/min (for N10 elements, only for Toploader version)
- 5/Z = Filter only (only for Toploader version)
- 10/Z = Filter only (only for Toploader version)

Version

- S = standard with motor (OLF-5, OLF-5/4, OLF-5/15)
- E = flow valve (10 to 50 bar) without motor (OLF-5)
- T = Toploader with or without motor (OLF-5/15, OLF-10/15, OLF-5/Z, OLF-10/Z)
- F = filter only (OLF-5)

Standard seal material is NBR (no need to specify).

For version in FKM (FPM, Viton®) add "V" here, e.g.: OLF-5-SV-...

Voltage supply

	OLF 5	OLF 5/4	OLF 5/15	OLF 10/15
120-N	120 W, 3x400 V 50 Hz	–	–	–
120-M	120 W, 1x230 V 50 Hz	–	–	–
120-K	120 W, 1x120 V 60 Hz	–	–	–
370-N	–	370 W, 3x400 V 50 Hz	370 W, 3x400 V 50 Hz	370 W, 3x400 V 50 Hz
370-M	–	370 W, 1x230 V 50 Hz	370 W, 1x230 V 50 Hz	370 W, 1x230 V 50 Hz
370-K	–	370 W, 1x120 V 60 Hz	370 W, 1x120 V 60 Hz	370 W, 1x120 V 60 Hz
200-U	200 W, 24 V DC	–	200 W, 24 V DC	200 W, 24 V DC
Z-Z	no motor	–	–	–

– not available

Others on request!

Element type

- N 5 DM 002 = DIMICRON filtration rating 2 µm absolute
- N 5 DM 005 = DIMICRON filtration rating 5 µm absolute
- N 5 DM 010 = DIMICRON filtration rating 10 µm absolute
- N 5 DM 020 = DIMICRON filtration rating 20 µm absolute
- N 5 AM 002 = AQUAMICRON filtration rating 2 µm absolute
- N 5 AM 020 = AQUAMICRON filtration rating 20 µm absolute
- N 10 DM 002 = DIMICRON filtration rating 2 µm absolute
- N 10 DM 005 = DIMICRON filtration rating 5 µm absolute
- N 10 DM 010 = DIMICRON filtration rating 10 µm absolute
- N 10 DM 020 = DIMICRON filtration rating 20 µm absolute
- N 10 AM 002 = AQUAMICRON filtration rating 2 µm absolute
- Z = without filter element

Clogging indicator

- E = back-pressure indicator (standard on OLF-5)
- F = pressure switch – electrical (VR2F.0)
- BM = visual differential pressure indicator (VM2BM.1) (standard on OLF-5/15)
- C = electrical differential pressure indicator (VM2C.0)
- D = visual/electrical differential pressure indicator (VM2D.0)
- Z = without clogging indicator

E, F not for sizes/versions OLF-5/15

BM, C, D not for sizes/versions OLF-5-S

For BM, C, D there is no back-pressure indicator

Supplementary details

- C = with ContaminationSensor CS 1310 (without display)
- CD = with ContaminationSensor CS 1320 (with display)
- AC = with ContaminationSensor CS 1310 and AquaSensor AS1000 (without display)
- ACD = with ContaminationSensor CS 1320 and AquaSensor AS3000 (with display)
- 7.5 = with 7.5 bar pressure relief valve

SRV flow control valve curve

(OLF-5-E...)

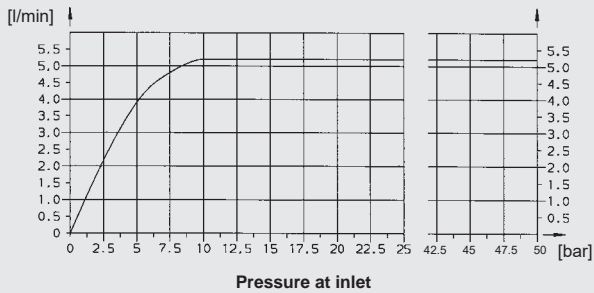

Application

- Tank volumes up to approx. 800 l
- Tank volumes up to approx. 2000 l

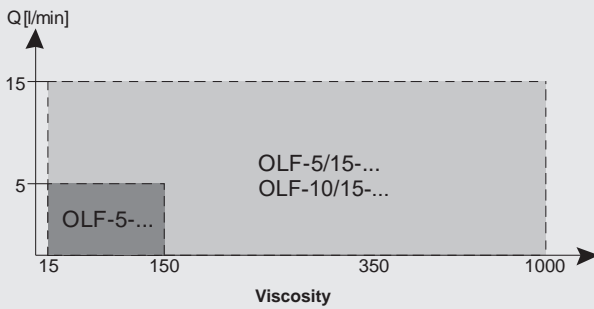

Tank volumes up to approx. 300 l

- Viscosity range in which the max. flow rate will only be achieved after approx. 10 minutes, if the pump is not primed.

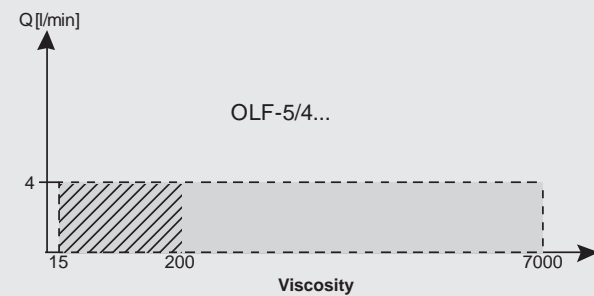

Dimensions

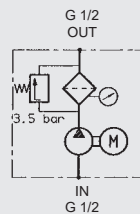
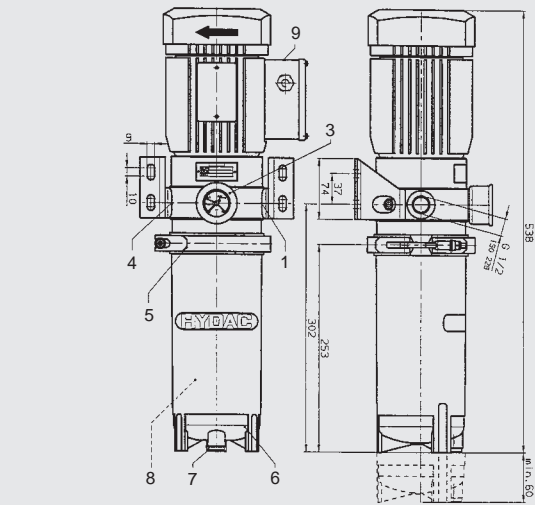

Example: OLF-5-S...

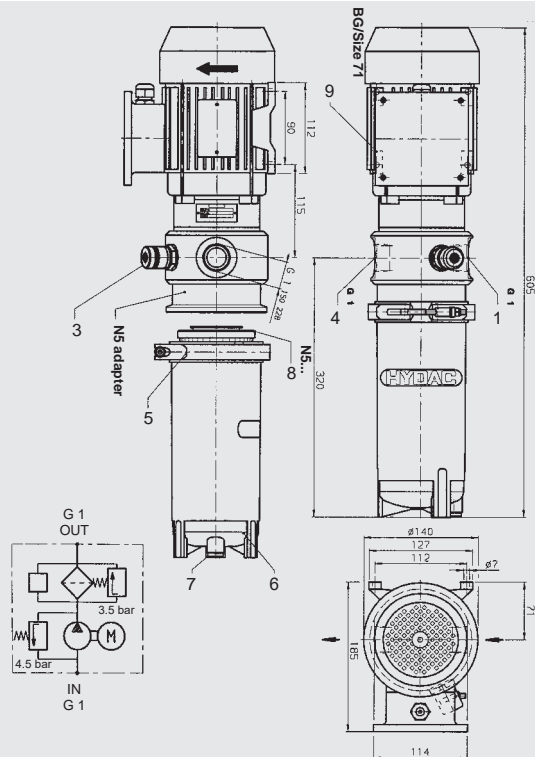

Example:
OLF-5/15-S..., OLF-5/4-S...

- 1 = Inlet
- 3 = Clogging indicator
- 4 = Outlet
- 5 = Clamp
- 6 = Filter bowl
- 7 = Drain
- 8 = Filter element
- 9 = Electric motor

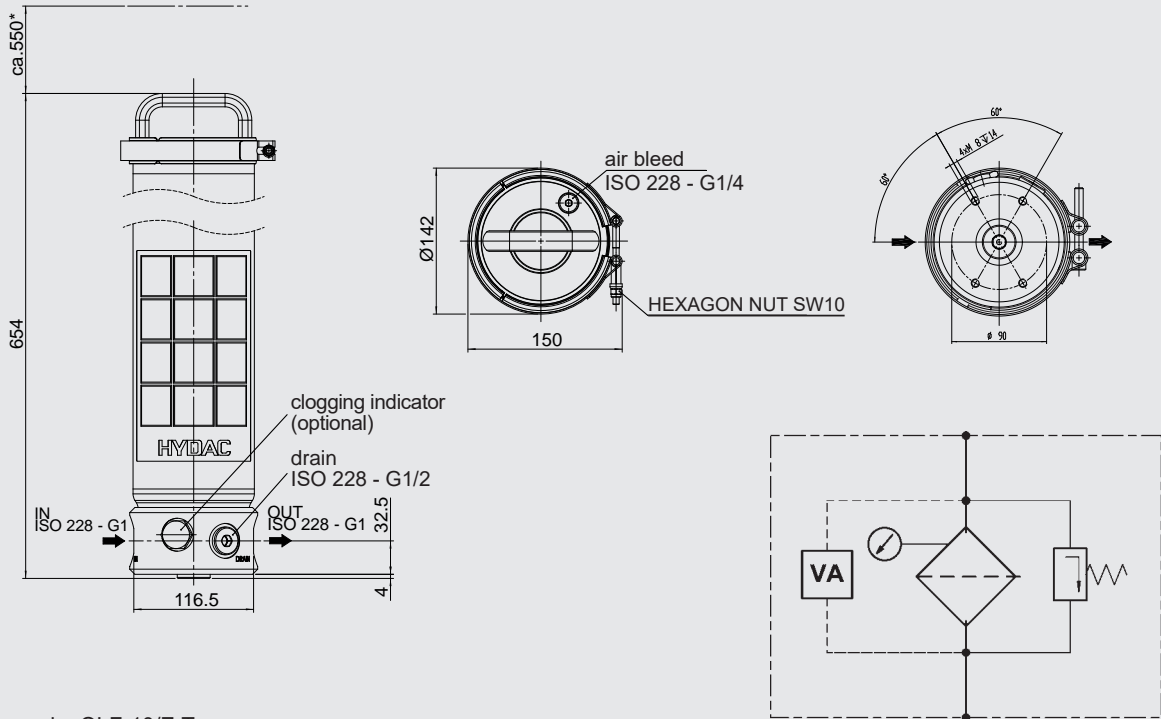

Example: OLF-10/Z-T...

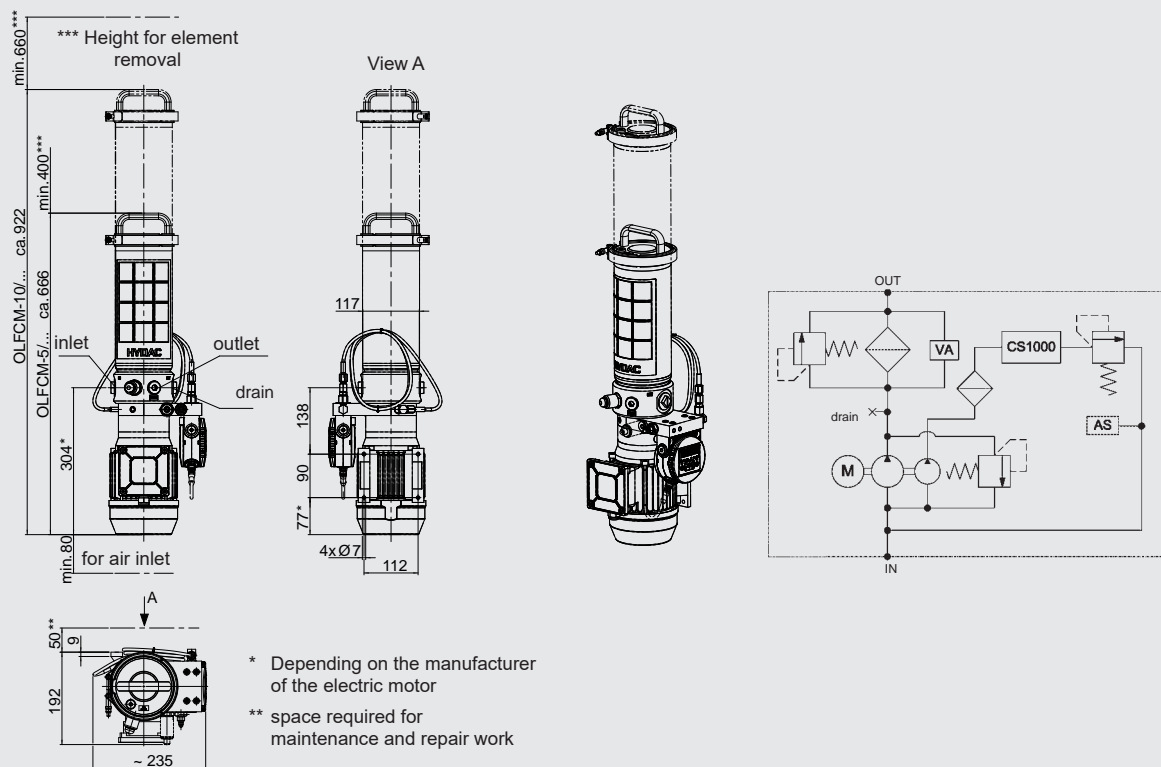

* Depending on the manufacturer of the electric motor

** space required for maintenance and repair work

Example:
OLFCM-5/15-T...
OLFCM-10/15-T...

Accessories

– Tank adapter kit OLF-5-TAK

Part No. 3039235

Quick retrofit kit to connect the OLF to hydraulic systems.

Can be installed on systems which have a breather filter with an interface to DIN 24557/Part 2.

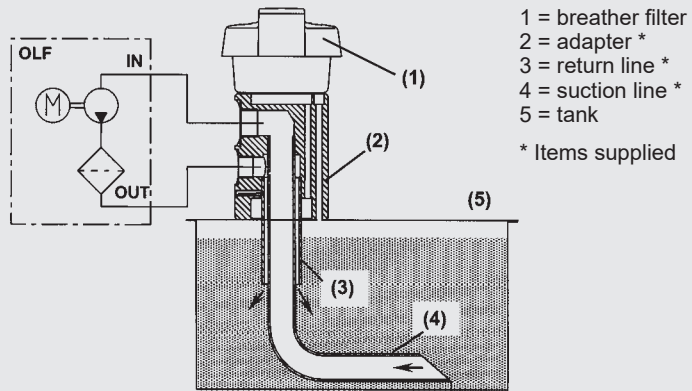

OLF-5-TAK

Replacement elements

Element type	Part number
N 5 DM 002	349494
N 5 AM 002	349677
N 5 DM 005	3068101
N 5 DM 010	3102924
N 5 DM 020	3023508
N 5 AM 020	3040345
N 10 DM 002	3539235
N 10 DM 005	3539237
N 10 DM 010	3539238
N 10 DM 020	3539242
N 10 AM 002	3582637



Niehues

Hydraulik · Automation

EN 7.920.12/11.21

Note

The information in this brochure relates to the operating conditions and applications described.

For applications and operating conditions not described, please contact the relevant technical department.

Subject to technical modifications.

HYDAC FILTER SYSTEMS GMBH

Industriegebiet

D-66280 Sulzbach / Saar

Tel.: +49 (0) 6897/509-01

Fax: +49 (0) 6897/509-9046

Internet: www.hydac.com

E-Mail: filtersystems@hydac.com