

Throttle check valve

Type Z2FS

RE 27518

Edition: 2019-07

Replaces: 2016-10



- ▶ Size 10
- ▶ Component series 3X
- ▶ Maximum operating pressure 315 bar [4569 psi]
- ▶ Maximum flow 160 l/min [42.3 US gpm]

Features

- ▶ Sandwich plate valve
- ▶ Porting pattern according to ISO 4401-05-04-0-05, NFPA T3.5.1 R2 and ANSI B93-7D05
- ▶ For the main or pilot flow limitation of 2 actuator ports.
- ▶ 3 adjustment types, optional:
 - Lockable rotary knob with scale
 - Spindle with internal hexagon and scale
 - Rotary knob with scale
- ▶ For supply or discharge throttling
- ▶ Corrosion-protected design

Contents

Features	1
Ordering code	2
Symbols	3
Function, section	4
Technical data	5
Characteristic curves	6
Dimensions	7 ... 10
Further information	10

2/10 **Z2FS** | Throttle check valve

Ordering code

01	02	03	04	05	06	07	08	09	10
Z2FS	10			- 3X	/				*

01	Twin throttle check valve, sandwich plate design	Z2FS
02	Size 10	10
03	Throttle check valve side A and B	- 1)
	Throttle check valve side A	A
	Throttle check valve side B	B

Adjustment type

04	Lockable rotary knob with scale	3 2)
	Spindle with internal hexagon and scale	5
	Rotary knob with scale	7
05	Component series 30 ... 39 (30 ... 39: unchanged installation and connection dimensions)	3X
06	With two throttle check valves, supply or discharge throttling (the valve can be rotated)	no code
	Supply throttling on side A (version "A...S")	S
	Supply throttling on side B (version "B...S")	
	Discharge throttling on side A (version "A...S2") Discharge throttling on side B (version "B...S2")	S2

Corrosion resistance

07	None	no code
	Improved corrosion protection (240 h salt spray test according to EN ISO 9227); (only version "5" without scale)	J3

Seal material

08	NBR seals	no code
	FKM seals	V
	Observe compatibility of seals with hydraulic fluid used. (Other seals upon request)	

Pilot oil duct

09	None	no code
	Via channel X and Y	S030
10	Further details in the plain text	

1) Identical adjustment types on sides A and B

 2) H-key with material no. **R900008158** is included in the scope of delivery.

Notes:

Preferred types and standard units are specified in the EPS (standard price list).

Symbols (① = component side, ② = plate side)

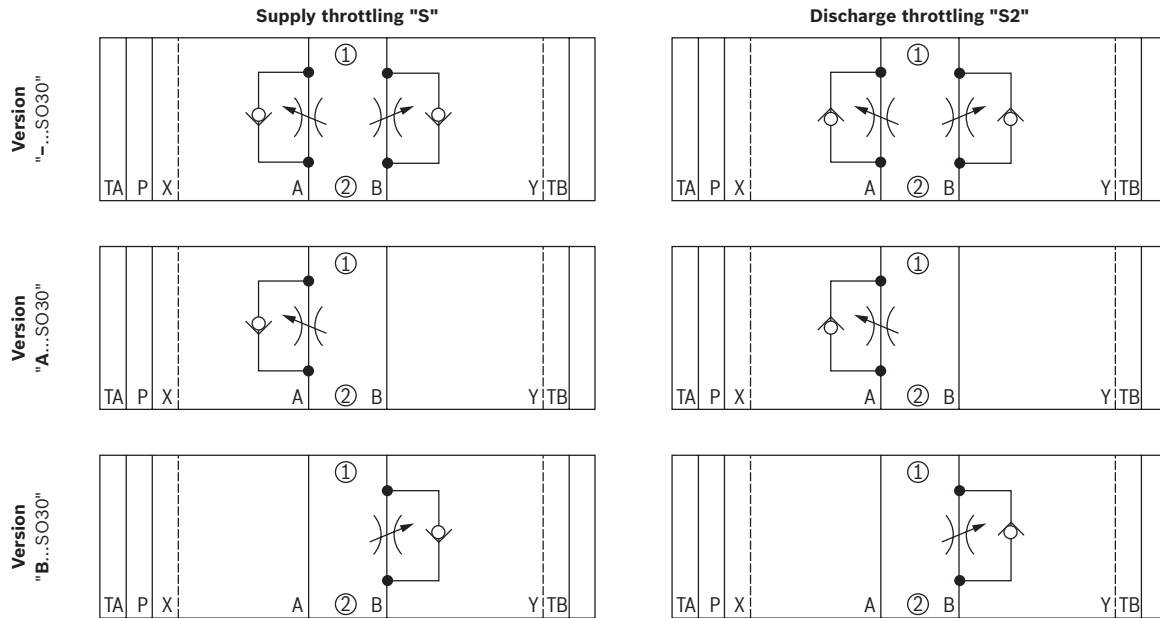

Notice:

- ▶ Deviating from ISO 4401, port T is called TA and port T1 is called TB in this data sheet.
- ▶ Version "SO30" is shown. The standard version does not have ports X and Y.

Function, section

The valve type Z2FS 10 is a throttle check valve in sandwich plate design. It is used for the main or pilot flow limitation of one or two actuator ports.

Two throttle check valves aligned symmetrically to each other limit flows in one direction and allow free return flow in the opposite direction.

In case of supply throttling, the hydraulic fluid is directed through channel A1 via throttling point (1) formed by the control edge (2) and the throttle spool (3.1) to actuator A2. The throttle spool (3.1) can be axially adjusted via the spindle (4) for adjustment of the throttling point (1).

Simultaneously, the hydraulic fluid in channel A1 is directed via the bore (5) to the piston side (6). The active pressure and the spring force retain the throttle spool (3.1) in throttle position.

The hydraulic fluid return flow from actuator B2 displaces the throttle spool (3.2) against the spring (7) and enables the unobstructed flow as check valve. Depending on the installation position, the throttling effect may occur in supply or discharge.

Main flow limitation

For actuator velocity adjustment (main flow limitation), the throttle check valve is installed between the directional valve and the subplate.

Pilot flow limitation

With pilot-operated directional valves, the throttle check valve can be applied for switching time adjustment (pilot flow limitation). In this case, it is installed between the pilot control valve and the main valve.

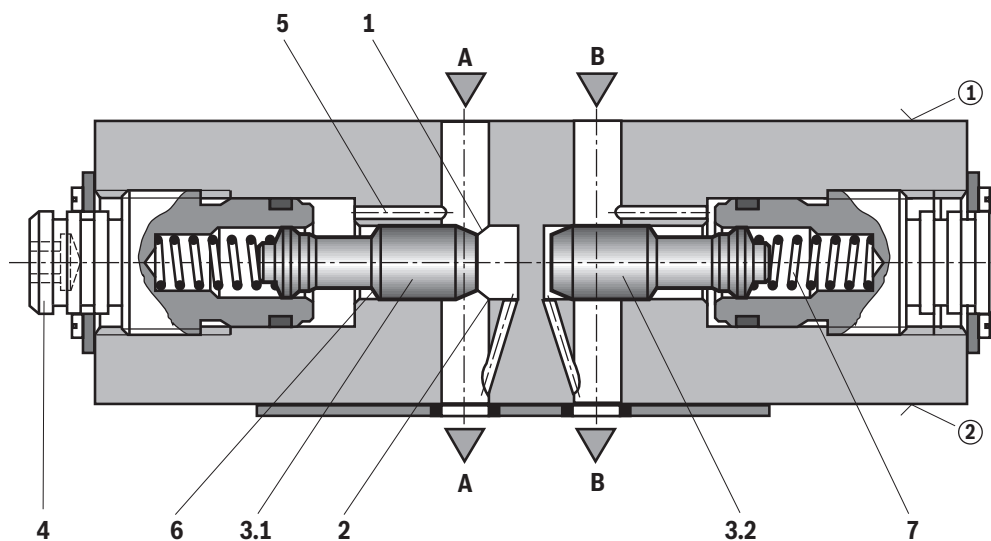

Supply throttling

Technical data

(For applications outside these parameters, please consult us!)

general		
Weight	kg [lbs]	Approx. 3.1 [6.8]
Installation position		Any
Ambient temperature range	°C [°F]	-30 ... -80 [-22 ... -176] (NBR seals) -20 ... +80 [-4 ... +176] (FKM seals)

hydraulic		
Maximum operating pressure	bar [psi]	315 [4569]
Maximum flow	l/min [US gpm]	160 [42.2]
Hydraulic fluid		See table below
Hydraulic fluid temperature range	°C [°F]	-30 ... -80 [-22 ... -176] (NBR seals) -20 ... +80 [-4 ... +176] (FKM seals)
Viscosity range	mm ² /s [SUS]	10 ... 800 [60 ... 3710]
Maximum admissible degree of contamination of the hydraulic fluid Cleanliness class according to ISO 4406 (c)		Class 20/18/15 ¹⁾

Hydraulic fluid	Classification	Suitable sealing materials	Standards	Data sheet	
Mineral oils	HL, HLP	NBR, FKM	DIN 51524	90220	
Bio-degradable ²⁾	▶ Insoluble in water	HETG HEES	FKM FKM	ISO 15380	90221
	▶ Soluble in water	HEPG	FKM	ISO 15380	
Flame-resistant	▶ Water-free	HFDU (glycol base)	FKM	ISO 12922	90222
		HFDU (ester base) ²⁾	FKM		
	▶ Containing water	HFC (Fuchs Hydrotherm 46M, Petrofer Ultra Safe 620)	NBR	ISO 12922	90223



Important information on hydraulic fluids:

- ▶ For more information and data on the use of other hydraulic fluids, please refer to the data sheets above or contact us.
- ▶ There may be limitations regarding the technical valve data (temperature, pressure range, life cycle, maintenance intervals, etc.).
- ▶ The ignition temperature of the hydraulic fluid used must be 50 K higher than the maximum surface temperature.

▶ Flame-resistant – containing water:

- Maximum pressure differential 210 bar, otherwise, increased cavitation erosion
- Life cycle as compared to operation with mineral oil HL, HLP 30 ... 100%
- Maximum hydraulic fluid temperature 60 °C

- ▶ **Bio-degradable and flame-resistant:** If this hydraulic fluid is used, small amounts of dissolved zinc may get into the hydraulic system.

¹⁾ The cleanliness classes specified for the components must be adhered to in hydraulic systems. Effective filtration prevents faults and at the same time increases the life cycle of the components.

For the selection of the filters, see www.boschrexroth.com/filter.

²⁾ Not recommended for corrosion-protected version "J3"

Characteristic curves

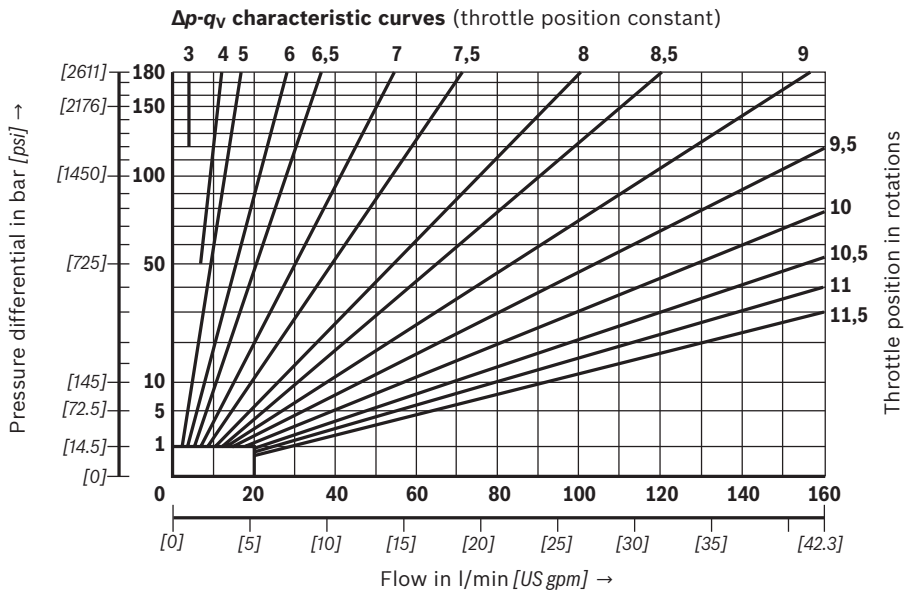
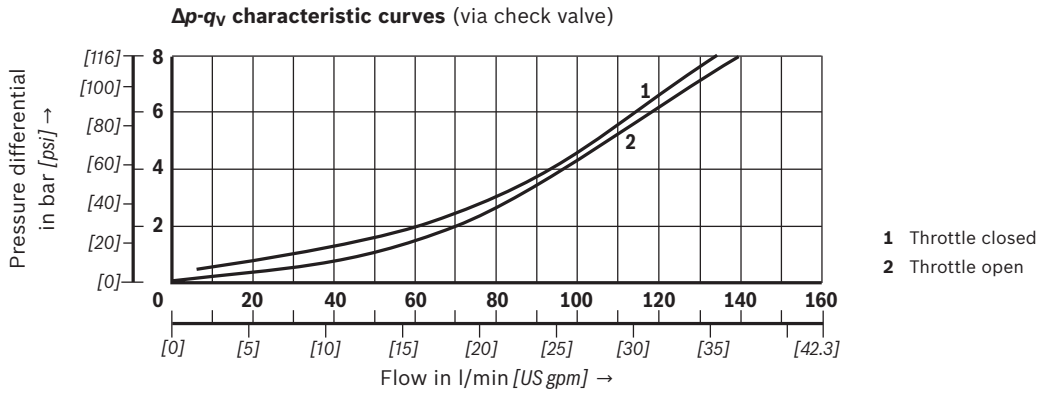
 (measured with HLP46, $\vartheta_{oil} = 40 \pm 5 \text{ } ^\circ\text{C}$ [104 ± 9 °F])

Dimensions: Version "-"
 (dimensions in mm [inch])

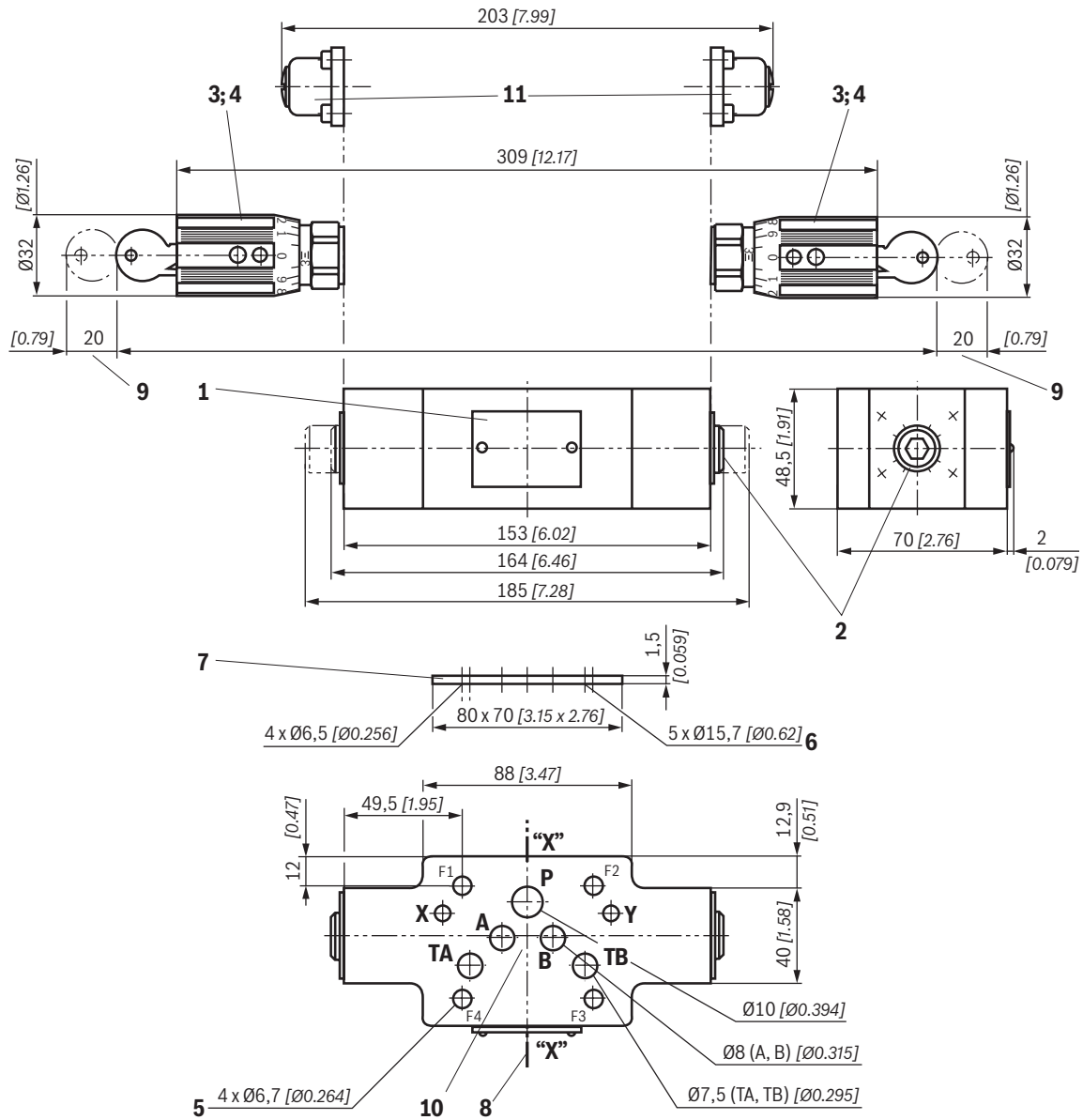

Notes:

- ▶ Deviating from ISO 4401, port T is called TA and port T1 is called TB in this data sheet.
- ▶ The dimensions are nominal dimensions which are subject to tolerances.
- ▶ Version "SO30" is shown. The standard version does not have ports X and Y.

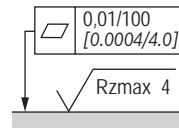

Required surface quality of the valve contact surface

Item explanations and valve mounting screws

see page 10.

8/10 **Z2FS** | Throttle check valve

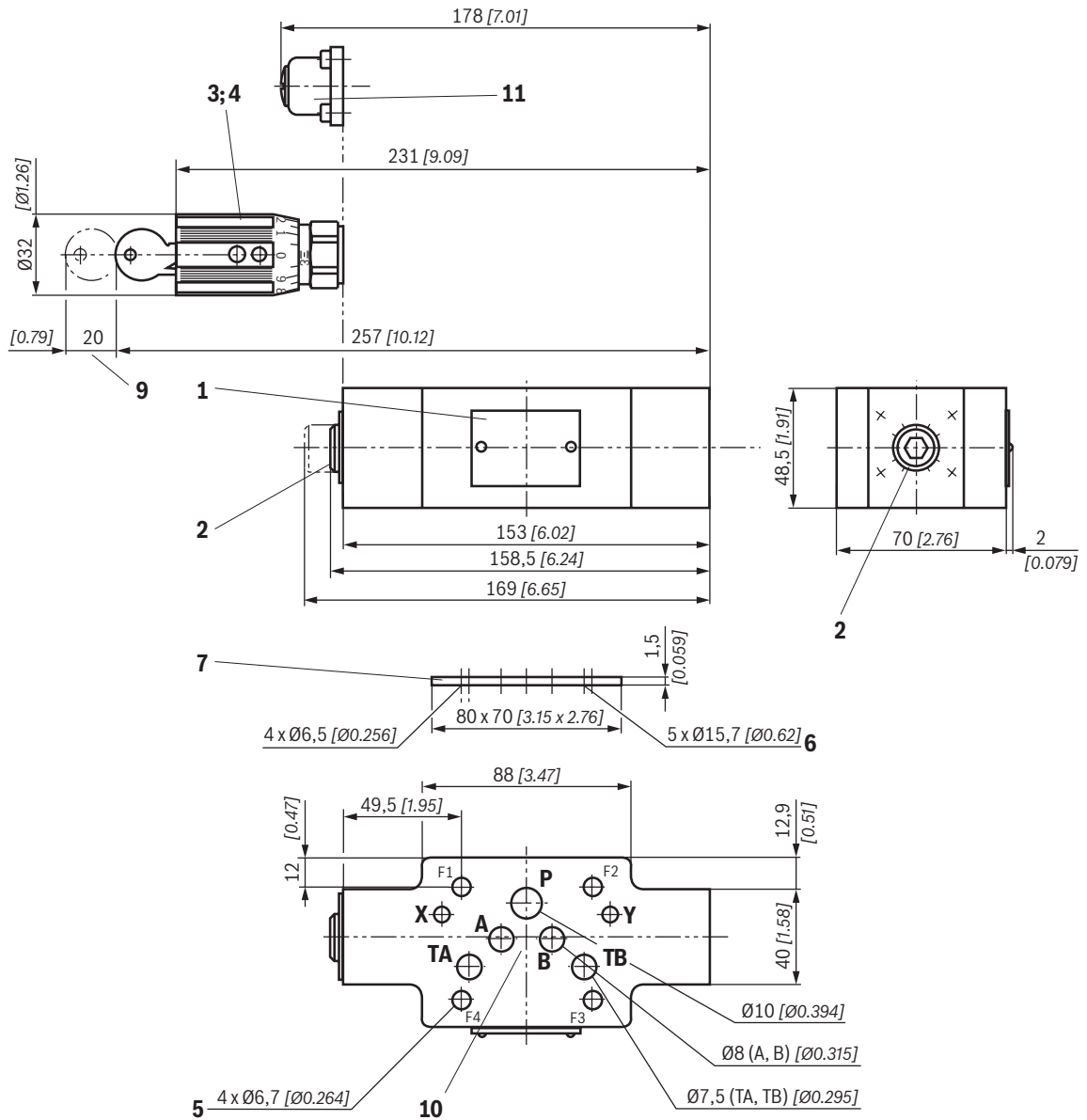
Dimensions: Version "A"
 (dimensions in mm [inch])

Notes:

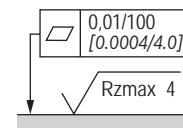
- ▶ Deviating from ISO 4401, port T is called TA and port T1 is called TB in this data sheet.
- ▶ The dimensions are nominal dimensions which are subject to tolerances.
- ▶ Version "SO30" is shown. The standard version does not have ports X and Y.



Required surface quality of the valve contact surface

Item explanations and valve mounting screws

see page 10.

Bosch Rexroth AG, RE 27518, edition: 2019-07

Archivierung: 11/2022

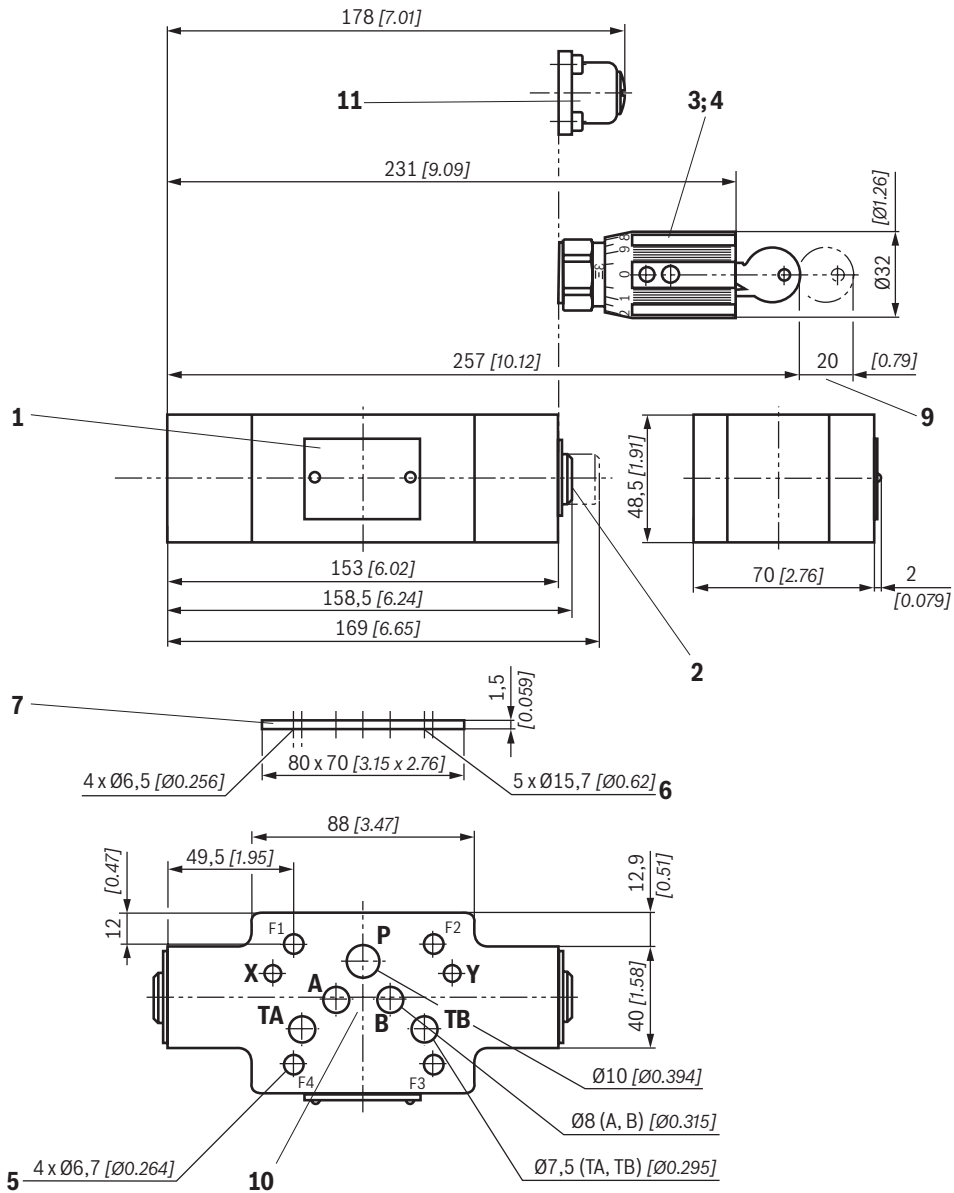
Dimensions: Version "B"
 (dimensions in mm [inch])

Notes:

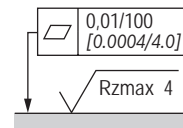
- ▶ Deviating from ISO 4401, port T is called TA and port T1 is called TB in this data sheet.
- ▶ The dimensions are nominal dimensions which are subject to tolerances.
- ▶ Version "SO30" is shown. The standard version does not have ports X and Y.



Required surface quality of the valve contact surface

Item explanations and valve mounting screws

see page 10.

Dimensions

- 1 Name plate
- 2 Adjustment type "5" – spindle for changing the flow cross-section (internal hexagon SW8)
 - ▶ Left rotation = higher flow
 - ▶ Right rotation = lower flow
- 3 Adjustment type "3"
- 4 Adjustment type "7"
- 5 4 through holes for valve mounting
- 6 Identical seal rings for ports A, B, P, TA, TB
- 7 R-ring plate
- 8 Modification from supply to discharge throttling is realized by rotation of the device around axis "X"-"X" (only with version "-")
- 9 Space required to remove the key
- 10 Porting pattern according to ISO 4401-05-04-0-05, NFPA T3.5.1 R2 and ANSI B93-7D05
- 11 Version "J"
To adjust the valve, disassemble the slotted screw. Further procedure see position 2 (adjustment type "5"). After setting of the valve, assemble the slotted screw.

Valve mounting screws (separate order)

4 hexagon socket head cap screws ISO 4762 - M6 - 10.9

4 hexagon socket head cap screws 1/4-20 UNC

Notes:

Length and tightening torque of the valve mounting screws must be calculated according to the components mounted under and over the sandwich plate valve.

Further information

- ▶ Subplates
- ▶ Hydraulic fluids on mineral oil basis
- ▶ Environmentally compatible hydraulic fluids
- ▶ Flame-resistant, water-free hydraulic fluids
- ▶ Flame-resistant hydraulic fluids - containing water (HFAE, HFAS, HFB, HFC)
- ▶ Hydraulic valves for industrial applications
- ▶ Use of non-electrical hydraulic components in an explosive environment (ATEX)
- ▶ Selection of the filters
- ▶ Information on available spare parts

Data sheet 45100

Data sheet 90220

Data sheet 90221

Data sheet 90222

Data sheet 90223

Operating instructions 07600-B

Data sheet 07011

www.boschrexroth.com/filter

www.boschrexroth.com/spc

Bosch Rexroth AG
Hydraulics
Zum Eisengießer 1
97816 Lohr am Main, Germany
Phone +49 (0) 93 52 / 18-0
documentation@boschrexroth.de
www.boschrexroth.de

© This document, as well as the data, specifications and other information set forth in it, are the exclusive property of Bosch Rexroth AG. It may not be reproduced or given to third parties without its consent.
The data specified above only serve to describe the product. No statements concerning a certain condition or suitability for a certain application can be derived from our information. The information given does not release the user from the obligation of own judgment and verification. It must be remembered that our products are subject to a natural process of wear and aging.

Notes

Bosch Rexroth AG
Hydraulics
Zum Eisengießer 1
97816 Lohr am Main, Germany
Phone +49 (0) 93 52/18-0
documentation@boschrexroth.de
www.boschrexroth.de

© This document, as well as the data, specifications and other information set forth in it, are the exclusive property of Bosch Rexroth AG. It may not be reproduced or given to third parties without its consent.
The data specified above only serve to describe the product. No statements concerning a certain condition or suitability for a certain application can be derived from our information. The information given does not release the user from the obligation of own judgment and verification. It must be remembered that our products are subject to a natural process of wear and aging.

Z2FS | Throttle check valve

Notes

Bosch Rexroth AG
Hydraulics
Zum Eisengießer 1
97816 Lohr am Main, Germany
Phone +49 (0) 93 52 / 18-0
documentation@boschrexroth.de
www.boschrexroth.de

© This document, as well as the data, specifications and other information set forth in it, are the exclusive property of Bosch Rexroth AG. It may not be reproduced or given to third parties without its consent.
The data specified above only serve to describe the product. No statements concerning a certain condition or suitability for a certain application can be derived from our information. The information given does not release the user from the obligation of own judgment and verification. It must be remembered that our products are subject to a natural process of wear and aging.