

HYDAC INTERNATIONAL



OffLine Filter OLF 15/30/45/60

Description

The OLF 15/30/45/60 series of filtration units are robust off-line filters for stationary applications in hydraulic and lubrication systems with a large fluid volume.

The Dimicron elements used in these filters are noted for their particularly high contamination retention capacity and an environmentally safe method of disposal (incinerable).

The optional monitoring equipment ContaminationSensor CS1000 is used to monitor the solid particle contamination in the oil. The AquaSensor AS1000 measures the water saturation (in %) as well as the temperature of the fluid.

To display the measurements, you can choose between the sensor displays or a central display with data storage using the SensorMonitoring Unit SMU 1200.

The measurements can simply be transferred from this to a PC using a USB memory stick or can be integrated into a plant control system using analogue outputs.

Applications

- Machine tools
- Plastic injection machines

Advantages

- Improved service life of components and system filter
- Greater machine availability
- Longer oil change intervals
- Very easy maintenance
- Elements have a high contamination retention capacity
- Environmentally safe disposal of elements (incinerable)
- Optional sensors available to monitor the contamination in the oil

Technical specifications

Filter housing	OLF-15	OLF-30	OLF-45	OLF-60
Filter element	N15DMxxx (1x)	N15DMxxx (2x)	N15DMxxx (3x)	N15DMxxx (4x)
Contamination retention capacity to ISO 16889	500 g	1000 g	1500 g	2000 g
Filtration performance data based on ISO 16889	$\beta_{2, 10, 20, 30} > 1000$ at $\Delta p = 2$ bar			
Permitted Δp across the element	4 bar			
Material of housing	Stainless steel 1.4301			
Weight of filter element	3.1 kg	6.2 kg	9.3 kg	12.4 kg
Volume of housing	20 l	40 l	60 l	78 l
Max. operating pressure	6 bar (others on request)			
Material of seals (standard)	NBR			
Weight without motor	25 kg	30 kg	40 kg	45 kg
Fluid temperature	10 to 80 °C			
Motor-pump unit	15 l/min	30 l/min	45 l/min	60 l/min
Operating pressure of the pump	4.5 to 5.5 bar			
Permitted suction pressure at suction port	-0.4 to 0.5 bar			
Viscosity range with vane pump OLF	15 to 500 mm ² /s			
Viscosity range with vane pump OLF _{CM}	15 to 200 mm ² /s			
Viscosity range with gear pump	15 to 1000 mm ² /s			
Viscosity range with centrifugal pump	1 to 20 mm ² /s			
Motor output				
Vane pump OLF	370 watts	750 watts	1500 watts	1500 watts
Vane pump OLF _{CM}	370 watts	1500 watts	1500 watts	1500 watts
Gear pump	370 watts	750 watts	1500 watts	1500 watts
Centrifugal pump	750 watts	750 watts	1500 watts	1500 watts
Weight of vane pump	9.8 kg	17.2 kg	23 kg	23 kg
Weight of gear pump	12.3 kg	17.6 kg	29 kg	29 kg
Weight of centrifugal pump	21.1 kg	21.1 kg	27.5 kg	27.5 kg
Material of seals in pump	NBR (option: FKM)			
Ambient temperature	-10 to 40 °C			
Protection class	IP 54			



Model code

OLF – 30/15 – S – N60 – N15DM002 – E/ – PKZ-V – ACD

Basic type

OLF = OffLine Filter stationary (with back-pressure indicator + drainage ball valve)
OLFCM = OffLine Filter stationary with FluidCondition Monitoring

Filter size and nominal flow rate

Without pump	15 l/min	30 l/min	45 l/min	60 l/min	
15/Z	15/15	X	X	X	1 filter element
30/Z	30/15	30/30	X	X	2 filter elements
45/Z	45/15	45/30	45/45	X	3 filter elements
60/Z	60/15	60/30	60/45	60/60	4 filter elements

X = not available

Pump type

S = vane pump (required for OLFCM)
G = gear pump
W = centrifugal pump
Z = without pump

Voltage

L = 115V – 1 Ph
M = 230V – 1 Ph*
W = 230V – 3 Ph*
C = 380V – 3 Ph
N = 400V – 3 Ph*
R = 415V – 3 Ph
G = 440V – 3Ph
O = 460V – 3Ph
B = 480V – 3Ph
S = 500V – 3Ph
P = 575V – 3Ph
X = other voltage on request L60, M60, ... = operation at 60 Hz
Z = without motor
Protection class: IP55
* Standard in Europe according to CENELEC HD472 S1 at 50 Hz

Filter element

N15DM002 = DIMICRON® 2 µm absolute
N15DM005 = DIMICRON® 5 µm absolute
N15DM010 = DIMICRON® 10 µm absolute
N15DM020 = DIMICRON® 20 µm absolute
N15DM030 = DIMICRON® 30 µm absolute
Z = without filter element

Clogging indicator

E = standard, back-pressure indicator
B = differential pressure gauge – visual (VM 2 BM.1)
C = differential pressure indicator – electrical (VM 2 C.0)
D3 = differential pressure indicator – visual/electrical (VM 2 D.0/-L220)
D4 = .../.../... (VM 2 D.0/-L24)
D5 = .../.../... (VD 2 LZ.1/-DB)
F = pressure switch - electrical

Supplementary details

PKZ = on and off switch with motor protection switch
FA0 = on and off switch with motor protection switch and supply voltage for sensors in OLFCM version.
FA1 = on and off switch with motor protection switch and switch-off when filter is clogged. Neutral wire required. only for voltages with maximum 240 V, 1 phase or maximum 415 V, 3 phases.
FA2 = on and off switch with motor protection switch and switch-off when filter is clogged. No neutral wire required. All voltages possible. Clogging indicator C type required.
FA3 = on and off switch with motor protection switch and switch-off when filter is clogged or target purity reached. No neutral wire required. All voltages possible. Clogging indicator C type required (only for OLFCM).
V = with FKM (FPM, Viton®) seals
MP = Mininess point upstream from filter for FCU incl. throttle valve
L = only filter housing without motor-pump unit, without tray

Monitoring devices (only for OLFCM)

C = ContaminationSensor CS1310 (without display)
CD = ContaminationSensor CS1320 (with display)
CS = ContaminationSensor CS1310 (without display) with SensorMonitoring Unit SMU1270
AC = Contamination Sensor CS1310 (without display) with AquaSensor AS1000 (without display)
ACD = ContaminationSensor CS1320 (with display) and AquaSensor AS3000 (with display)
ACS = ContaminationSensor CS1310 (without display) and AquaSensor AS1000 (without display) with SensorMonitoring Unit SMU1270

Note: When operating at 60 Hz the flow rate can increase by approx. 20 %.

Hydraulic circuit

OLF without motor-pump unit

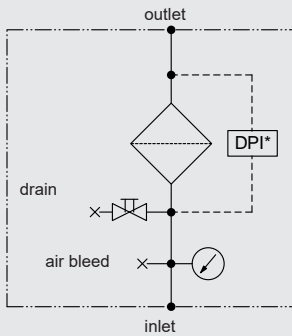

* Optional differential pressure indicator

OLF with motor-pump unit

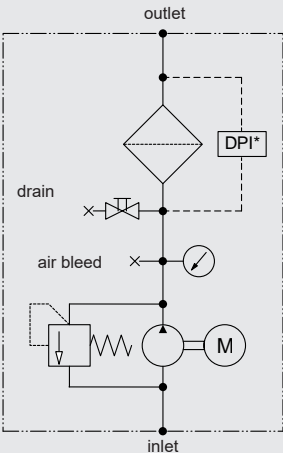

* Optional differential pressure indicator

OLFCM 15-60

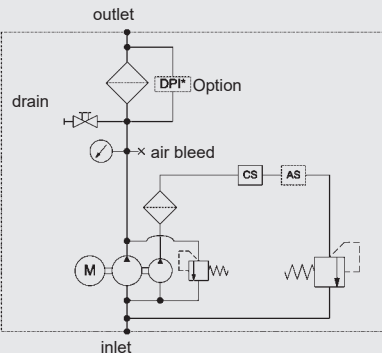

* DPI = Differential pressure indicator

Connections

	Vane pump	Gear pump	Centrifugal pump
Inlet (OLF15, OLFCM15)	G 3/4	G 3/4	G 1
Inlet (OLF30)	G 1 1/4	G 1	G 1
Inlet (OLFCM30)	M45	-	-
Inlet (OLF45, OLF60)	G 1 1/4	G 1 1/2	G 1 1/4
Inlet (OLFCM45, OLFCM60)	M45	-	-

Element pressure drop

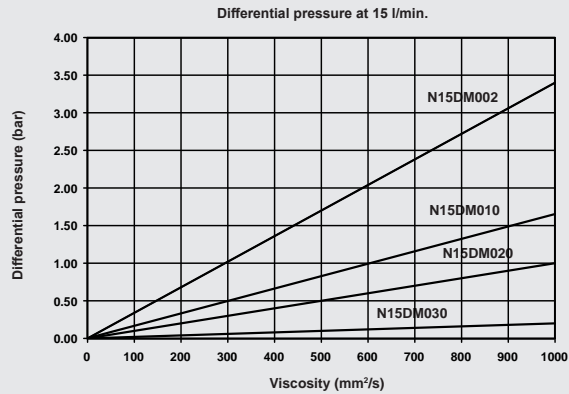

Dimensions

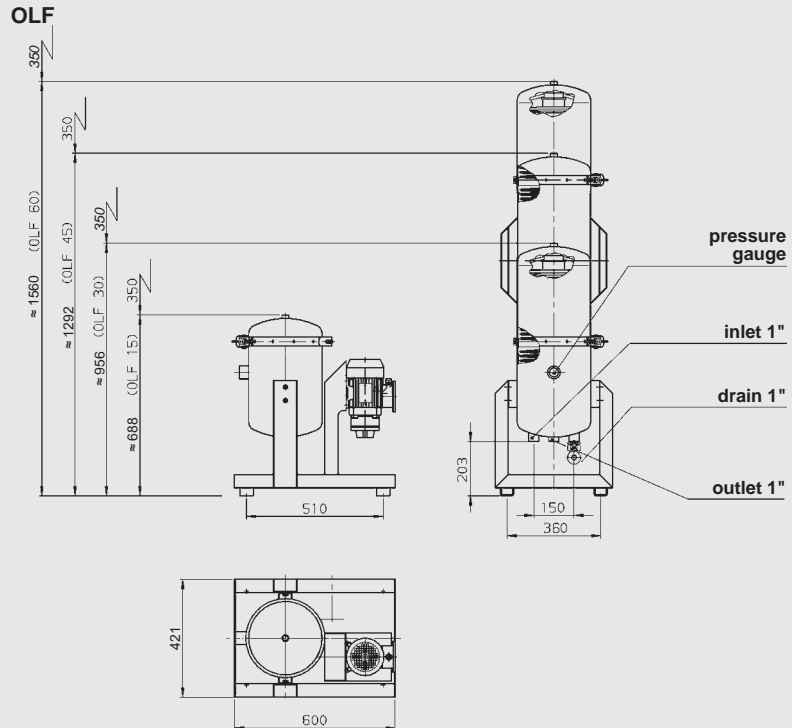

Example OLF-15/Z

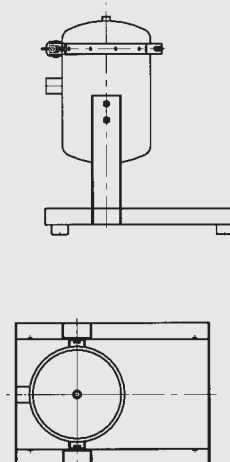

Dimensions

OLFCM

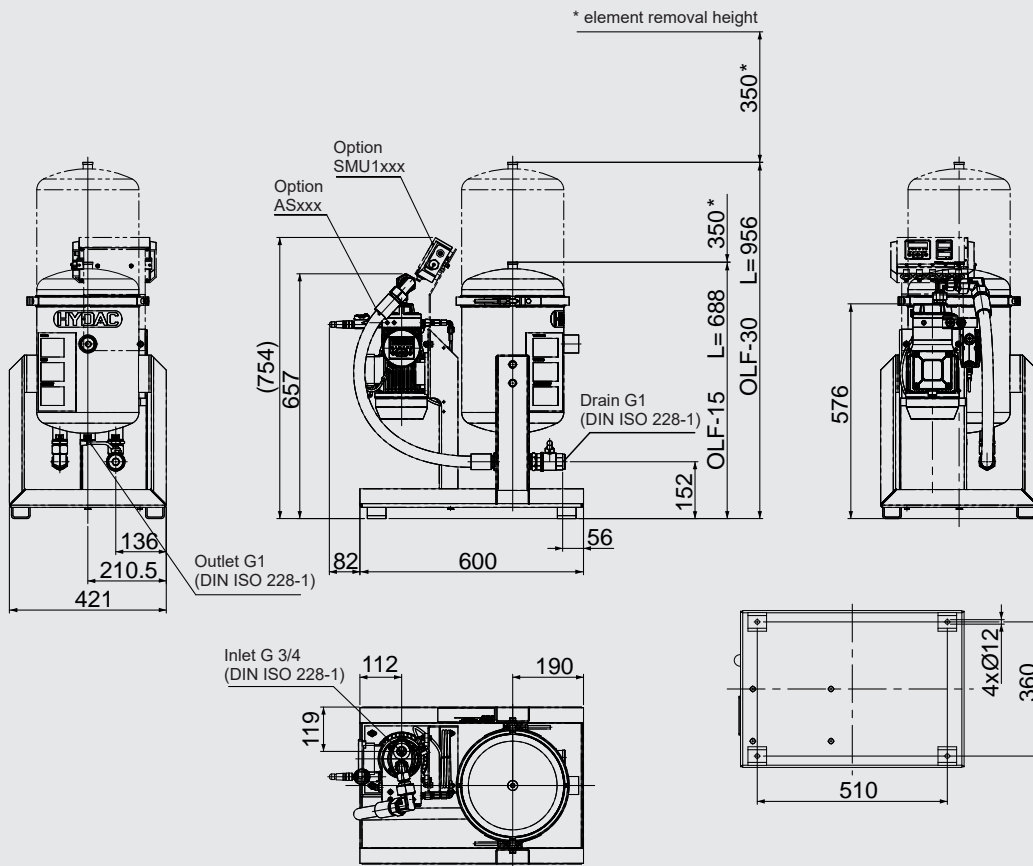

Optional differential pressure indicator

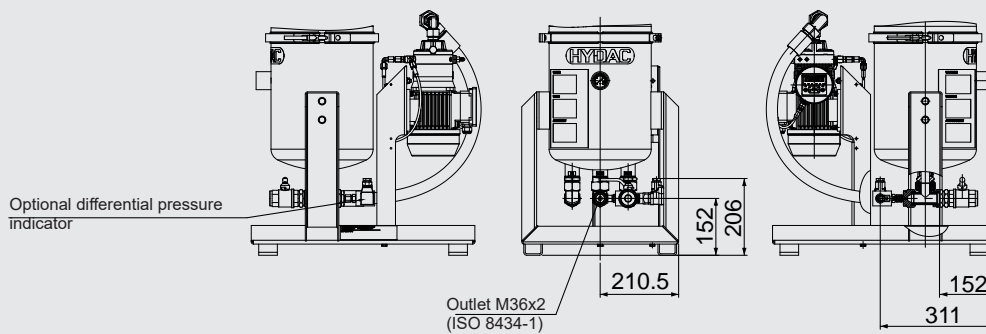

Note

The information in this brochure relates to the operating conditions and applications described.

For applications or operating conditions not described, please contact the relevant technical department.

Subject to technical modifications.

HYDAC FILTER SYSTEMS GMBH

Industriegebiet

D-66280 Sulzbach / Saar

Tel.: +49 (0) 6897/509-01

Fax: +49 (0) 6897/509-9046

Internet: www.hydac.com

E-mail: filtersystems@hydac.com