

Technical Information

Orbital Motors

Type OMP X and OMR X

powersolutions.danfoss.com

Archivierung: 12/2023

Technical Information

Orbital Motors Type OMP X and OMR X

Revision history*Table of revisions*

Date	Changed	Rev
January 2018	Major revision.	0201
February 2017	First edition.	0101

Contents
General Information

Orbital Motors Introduction.....	5
Orbital Motors Features.....	6
Technical Features.....	6
Orbital Motors Application Areas.....	6
Orbital Motors Literature Overview.....	7
Operating Parameters Diagrams.....	7

OMP X configuration versions overview with codes numbers

OMP X standard motors.....	9
Side port offset 2-hole oval mounting flange (A2 flange).....	9
Side port aligned 2-hole oval mounting flange (A2 flange).....	10
Side port aligned with square mounting flange (C-flange).....	11
Wheel mounting flange type.....	12
OMPW X N motors with needle bearings.....	13
Wheel mounting flange type.....	13
OMP X motors with free running gerotor.....	14
Side port offset with 2-hole oval mounting flange (A2 flange).....	14

OMP X Model Code
OMP X technical data

OMP X motor specification.....	18
High Pressure Shaft Seal in OMP X and OMR X motors.....	19
Pressure drop in OMP X motor.....	19
Oil flow in drain line.....	20
Direction of shaft rotation: clockwise.....	20
OMP X and OMR X shaft loads.....	21
OMP X N shaft loads.....	22
OMPW X with slide bearings shaft loads.....	23
OMPW X N with needle bearing shaft loads.....	24

OMP X function diagrams

OMP X 25.....	25
OMP X 32.....	26
OMP X 40.....	26
OMP X 50.....	27
OMP X 80.....	27
OMP X 100.....	28
OMP X 125.....	28
OMP X 160.....	29
OMP X 200.....	29
OMP X 250.....	30
OMP X 315.....	30
OMP X 400.....	31

OMP X shaft version

OMP X and OMR X shaft versions.....	32
-------------------------------------	----

OMP X port thread versions

Main port thread versions.....	35
OMP X manifold mount.....	35

OMP X dimensions

EU version side port offset with 2-hole oval mounting flange (A2-flange)	36
EU version end port with 2-hole oval mounting flange (A2-flange).....	37
EU version OMPW X and OMPW X N motors wheel type.....	38
US version side port offset with 2-hole oval mounting flange (A2-flange).....	39
US version side port aligned with 2-hole oval mounting flange (A2-flange)	40
US version side port aligned with square mounting flange (C-flange).....	41

OMR X configuration versions overview with codes numbers

OMR X standard motors.....	42
----------------------------	----

Contents

Side port offset 2-hole oval mounting flange (A2 flange).....	42
Side port aligned with 2-hole oval mounting flange (A2 flange).....	43
Side port aligned with square mounting flange (C flange).....	44
OMR X N motors with needle bearings.....	45
Side port offset 2-hole oval mounting flange (A2-flange).....	45
OMR X Model Code	
OMR X technical data	
OMR X motor specification.....	49
High Pressure Shaft Seal in OMP X and OMR X motors.....	50
Pressure drop in OMR X motor.....	50
Oil flow in drain line.....	51
Direction of shaft rotation: clockwise.....	51
OMP X and OMR X shaft loads.....	52
OMR X N with needle bearings shaft loads.....	53
OMR X function diagrams	
OMR X 50.....	54
OMR X 80.....	55
OMR X 100.....	55
OMR X 125.....	56
OMR X 160.....	56
OMR X 200.....	57
OMR X 250.....	57
OMR X 315.....	58
OMR X 375.....	58
OMR X 400.....	59
OMR X Shaft version	
OMP X and OMR X shaft versions.....	60
OMR X port thread versions	
Main port thread versions.....	63
OMR X manifold mount.....	63
OMR X dimensions	
EU version side port offset with 2-hole oval mounting flange (A2-flange).....	64
EU version end port version with 2-hole oval mounting flange (A2-flange).....	65
US version side port offset with 2-hole oval mounting flange (A2-flange).....	66
US version side port aligned with 2 hole oval mounting flange (A2)	67
US version side port aligned with square mounting flange (C-flange).....	68
Weight of motors	
Weight of OMP X and OMR X motors.....	69

General Information

Orbital Motors Introduction

Danfoss is a world leader within production of low speed orbital motors with high torque. We can offer more than 3000 different orbital motors, categorized in types, variants and sizes (including different shaft versions).

The motors size vary (rated displacement) from 8 to 800 cm³ [0.50 to 48.9 in³] per revolution.

- Small sized motors:
 - OML and OMM
- Medium sized motors:
 - OMP, OMR and OMH
 - OMP X and OMR X
 - DH and DS
 - OMEW
- Large sized motors:
 - OMS, OMT and OMV
 - TMK
 - TMT
 - TMTHW
 - TMVW

Speeds range up to approximate 2500 min⁻¹ (rpm) for the smallest type and up to approximate 600 min⁻¹ (rpm) for the largest type.

Maximum operating torques vary from 13 to 4000 N·m [115 to 35 400 lb·in] (peak) and maximum outputs are from 2.0 to 95 kW [2.7 to 128 hp].

Wide range of Danfoss orbital motors

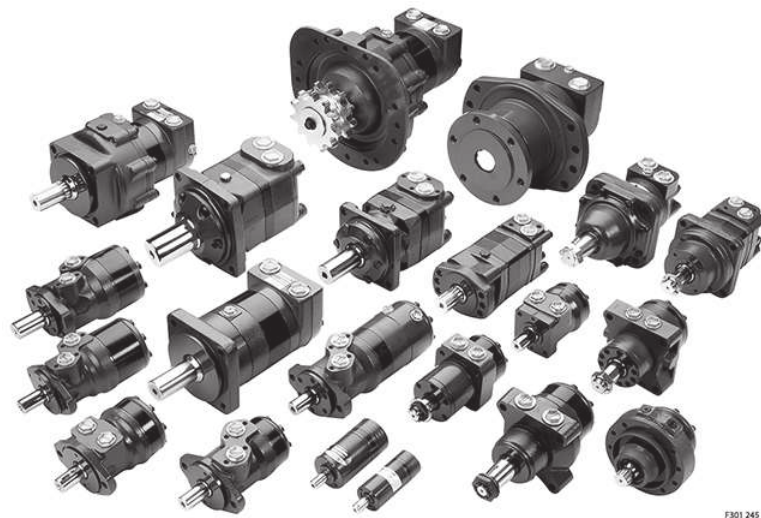

General Information**Orbital Motors Features**

- Smooth running over the entire speed range
- Constant operating torque over a wide speed range
- High starting torque
- High return pressure without the use of drain line (high pressure shaft seal)
- High efficiency
- High radial and axial bearing capacity
- Long life under extreme operating conditions
- Robust and compact design
- For applications in both open and closed loop hydraulic systems
- Suitable for a wide variety of hydraulics fluids

Technical Features

The program is characterized by technical features appealing to a large number of applications and by motors that can be adapted to a given application.

Adaptions comprise the following variants:

- Motors with:
 - corrosion resistant parts
 - needle bearing (OMPW X N, OMR X N)
 - low leakage version or super low leakage version (OMR, OMR X)
 - integrated negative holding brake
 - integrated flushing valve
 - speed sensor
 - tachometer connection
 - black finish paint
- Short motors without bearings or Ultra short motors
- Wheel motors with recessed mounting flange

Orbital Motors Application Areas

The orbital motors are used in the following application areas:

- Construction equipment
- Agricultural equipment
- Material handling & Lifting equipment
- Forestry equipment
- Lawn and turf equipment
- Machine tools and stationary equipment
- Marine equipment
- Special purpose

General Information
Orbital Motors Literature Overview

A general catalog of all Orbital Motors with technical data gives a quick motor reference based on: selection of orbital motor, function in hydraulic systems, power, torque, speed and capabilities. More detailed information can be found in an individual motor catalogs.

Literature title	Literature type	Reference number
Orbital Motors in General	Technical Information	BC00000083
OML and OMM Orbital Motors	Technical Information	BC00000087
OMP, OMR and OMH Orbital Motors	Technical Information	BC00000084
OMS, OMT and OMV Orbital Motors	Technical Information	BC00000090
DH and DS Orbital Motors	Technical Information	BC00000092
OMEW Orbital Motors	Technical Information	BC00000062
TMK, TMKW, TMK FL Orbital Motors	Technical Information	BC00000098
TMT, TMTU, TMTW, TMT FL Orbital Motors	Technical Information	BC00000102
TMTHW Orbital Motors	Technical Information	BC00000230

Operating Parameters Diagrams

The bar diagrams are useful for a quick selection of relevant motor size for the application. The final motor size can be determined by using the function diagram for each motor size.

The function diagrams are based on actual tests on a representative number of motors from our production. The diagrams apply to a return pressure between 5 and 10 bar [75 and 150 psi] when using mineral based hydraulic oil with a viscosity of 35 mm²/s [165 SUS] and a temperature of 50°C [120°F].

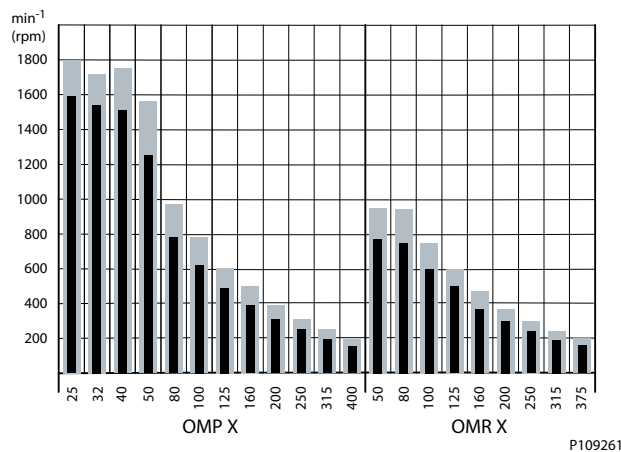
Speed
Maximum speed

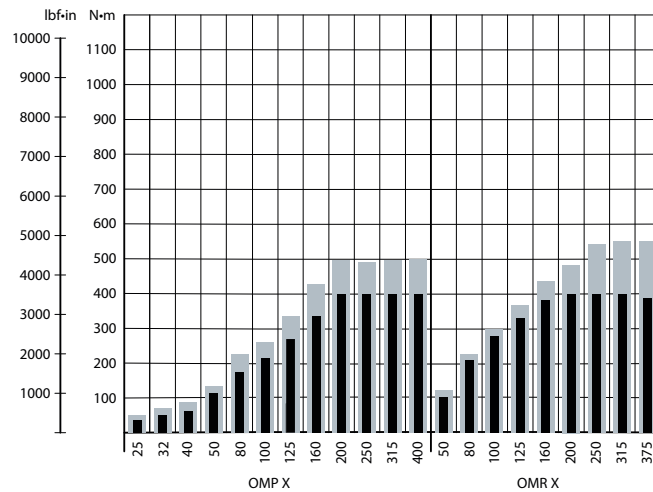
General Information
Torque
Maximum torque

P109262

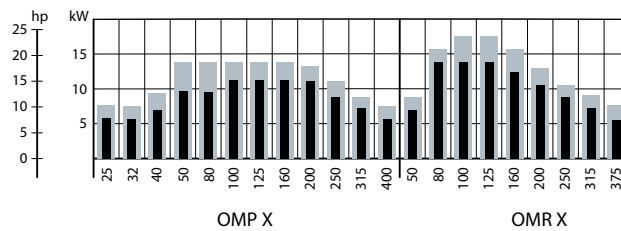
Output
OMP X and OMR X maximum output

①
 ②

P109263

1. Intermittent values
2. Continuous values

For more information about how to read and use the function diagrams, please see the paragraph "Selection of motor size" in the general technical information *Orbital Motors* **BC00000083**.

For more information about OMP X and OMPW X, see [OMP function diagrams](#)

For more information about OMR X, see [OMR function diagrams](#)

OMP X configuration versions overview with codes numbers

The following tables show the different versions configuration codes.

- OMP X standard motors:
 - [Side port offset 2-hole oval mounting flange \(A2 flange\)](#) on page 9
 - [Side port aligned 2-hole oval mounting flange \(A2 flange\)](#) on page 10
 - [Side port aligned with square mounting flange \(C-flange\)](#) on page 11
 - [Wheel mounting flange type](#) on page 12
- OMPW X N motors with needle bearings: [Wheel mounting flange type](#) on page 13
- OMP X motors with free running gerotor: [Side port offset with 2-hole oval mounting flange \(A2 flange\)](#) on page 14

If the desired OMP X could not be found please use the [OMP X Model Code](#) on page 15.

OMP X standard motors

For ordering please use the code numbers shown in the table on the following pages.

For OMP X motors with a configuration which is not available in the code number tables please use the model code number system in the [OMP X Model Code](#) on page 15 to specify the OMP X motor on detail.

Side port offset 2-hole oval mounting flange (A2 flange)

Configuration code numbers are set according to OMP X motor mounting flange type.

Configuration codes A1 – A5 description

Pilot diameter	Ø 82.5 mm [3.25 in]				
Bolt circle dia.	Ø 106.4 mm [4.20 in]				
Conf. code	A2	A1	A3	A4	A5
Shaft	Cyl. Ø25 mm	Cyl. Ø25 mm	Cyl. 1 in	Cyl. 1 in	Splined 1 in
Main port	G1/2	G1/2	G1/2	7/8 -14 UNF	G1/2
Drain port	G1/4	G1/4	G1/4	7/16-20 UNF	G1/4
Port type	End port	Side port offset			
Check valve	Yes				
Shaft seal	High pressure shaft seal				
Designation	Main type designation: OMP X				

Code numbers for configuration codes A1 – A5

Code	Displacement											
	25	32	40	50	80	100	125*	160	200	250	315	400
A1	11185769	11185775	11186719	11185771	11186721	11186725	11185743	11186705	11186708	11186711	11186712	11186714
A2	–	–	11185711	11185710	11185713	11185714	–	11185704	11185705	11185706	11185707	11185708
A3	–	–	–	11186729	11185808	11186730	11185792	11186726	11185796	11185798	11186728	11185802
A4	11185720	11185721	11185723	11185722	11185724	11185726	11185725	11185715	11185716	–	11185718	11185719
A5	–	–	–	11186738	11186739	11186740	11186731	11186732	11185819	11186820	11185827	11186737

* Motor 11185725 is painted black.

OMP X configuration versions overview with codes numbers
Side port aligned 2-hole oval mounting flange (A2 flange)

Configuration code numbers are set according to OMP X motor mounting flange type.

Configuration codes A6 – A10 description

Pilot diameter	Ø 82.5 mm [3.25 in]				
Bolt circle dia.	Ø 106.4 mm [4.20 in]				
Conf. code	A6	A7	A8	A9	A10
Shaft	Cyl. 1 in	Cyl. 1 in	Splined 1 in	Cyl. 1 in; CH 8	Cyl. 1 in; CH 10.3
Main port	7/8–14 UNF	1/2–14 UNF	7/8–14 UNF	7/8–14 UNF	7/8–14 UNF
Drain port	7/16–20 UNF				
Port type	Side port offset				
Check valve	Yes				
Shaft seal	High pressure shaft seal				
Designation	Main type designation: OMP X				

Code numbers for codes A6 – A10 (Size 25 — 80 cm³)

Code	Displacement						
	25	32	36	40	50	60	80
A6	–	–	11186086	11186085	11186695	11186086	11186085
A7	–	–	11186116	11186115	11186117	11186116	11186115
A8	–	–	11186071	11186069	11186072	11186071	11186069
A9	83062875	83062884	83062885	83062886	83062887	83062888	11186092
A10	83062939	83062940	83062941	83062942	11186091	83062943	83062944

Code numbers for codes A6 – A10 (Size 100 — 400 cm³)

Code	Displacement						
	100	125	160	200	250	315	400
A6	11186090	11186075	11186076	11186077	11186079	11186081	11186083
A7	11186118	—	11186110	11186111	11186112	11186113	11186818
A8	11186073	—	11186064	11186065	11186066	11186067	11186068
A9	11186093	83062889	83062890	83062891	83062902	83062903	83062904
A10	83062945	83062946	83062947	83062948	83062949	83062950	83062951

OMP X configuration versions overview with codes numbers
Side port aligned with square mounting flange (C-flange)

Configuration code numbers are set according to OMP X motor mounting flange type.

Configuration codes B1 – B4 description

Pilot diameter	Ø 44.4 mm [1.75 in]			
Bolt circle diameter	Ø 106.4 mm [4.20 in]			
Conf. code	B1	B2	B3	B4
Shaft	Cylindrical 1 in	Cylindrical 1 in	Cyl. 1 in, CH8	Cyl. 1 in, CH10.3
Main port size	7/8–14 UNF	1/2–14 NPTF	7/8–14 UNF	
Drain port size	7/16–20 UNF			
Port type	Side port aligned			
Check valve	Yes			
Shaft seal	High pressure shaft seal			
Designation	Main type designation: OMP X			

Code numbers for B1 – B4 (Size 25 — 80 cm³)

Code	Displacement						
	25	32	36	40	50	60	80
B1	–	–	11186056	–	11186054	–	11186693
B2	–	–	11186132	–	11186131	–	11186133
B3	83062956	83062957	83062958	83062959	83062960	83062961	83062992
B4	83063000	83063001	83063002	83063003	11186060	83063004	11186061

Code numbers for B1 – B4 (Size 100 — 400 cm³)

Code	Displacement						
	100	125	160	200	250	315	400
B1	11186059	11186691	11186044	11186046	11186047	11186049	11186052
B2	11186134	11186125	11186126	11186127	11186128	11186129	11186130
B3	83062993	83062994	83062995	83062996	83062997	83062998	83062999
B4	11186062	83063005	83063006	83063007	83063008	83063009	83063010

OMP X configuration versions overview with codes numbers
Wheel mounting flange type

Configuration code number is set according to OMPW X motor mounting flange **Wheel** type.

Configuration code C1 description

Configuration code	C1
Pilot diameter	Ø 80 mm [3.15 in]
Bolt circle diameter	Ø 103 mm [4.06 in]
Shaft	Cylindrical Ø 25 mm [Dia 0.984 in]
Main port size	G1/2
Drain port size	G1/4
Port type	Side port
Check valve	Yes
Shaft seal	High pressure shaft seal
Designation	Main type designation: OMPW X

Code numbers for C1

Code	Displacement									
	40	50	80	100	125	160	200	250	315	400
C1	11185874	11185873	11185875	11185877	11185876	11186746	11186747	11185870	11185871	11185872

Technical Information
Orbital Motors Type OMP X and OMR X
OMP X configuration versions overview with codes numbers
OMPW X N motors with needle bearings
Wheel mounting flange type

 Configuration code number is set according to OMPW X N motor mounting flange **Wheel** type.

Configuration code E1 description

Configuration code	E1
Pilot diameter	Ø 80 mm [3.15 in]
Bolt circle diameter	Ø 103 mm [4.06 in]
Shaft	Tapered Ø 28.5 mm [Dia 1.122 in]
Main port size	G1/2
Drain port size	G1/4
Port type	Side port
Check valve	Yes
Shaft seal	High pressure shaft seal
Designation	Main type designation: OMPW X N

Code numbers for E1

Code	Displacement										
	25	40	50	80	100	125	160	200	250	315	400
E1	11185887	11185889	11185888	11185890	11185892	11186750	11185882	11186748	11185884	11185885	11185886

OMP X configuration versions overview with codes numbers
OMP X motors with free running gerotor
Side port offset with 2-hole oval mounting flange (A2 flange)

Configuration code **F1** is set according to OMP X motor mounting flange type: Side port offset with 2-hole oval mounting flange (A2-flange).

Configuration code F1 description

Configuration code	F1
Pilot diameter	Ø 82.5 mm [3.25 in]
Bolt circle diameter	Ø 106.4 mm [4.20 in]
Shaft	Cylindrical Ø 25 mm [Dia 0.984 in]
Main port size	G1/2
Drain port size	G1/4
Port type	Side port offset
Check valve	Yes
Shaft seal	High pressure shaft seal
Designation	Main type designation: OMP X

Code numbers for F1

Code	Displacement				
	100	125	160	200	315
F1	11185790	11185746	11186707	11185751	11185761

Technical Information
Orbital Motors Type OMP X and OMR X
OMP X Model Code

The coding system has been developed to identify the configuration options for the OMP X motors. The model code begins with the motor family and the remaining fields are filled in to configure the motor with the desired features, all fields must be filled in. *Example: OMPX-200-NNN-B11-SO-A3-A11-C-E-B-1-N-N-NN-NNN-NNN-NNN-A-NN.*

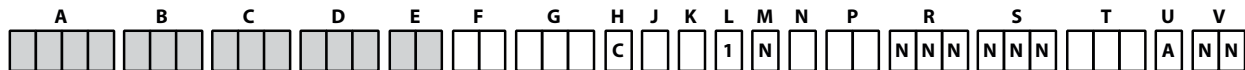
A – Main motor family

OMPX	OMP X motor series
-------------	--------------------

B – Motor displacement

Code	Displacement, cm ³ /rev [in ³ /rev]	Code	Displacement, cm ³ /rev [in ³ /rev]
025	25.0 [1.53]	100	97.3 [5.94]
032	32.0 [1.95]	125	125.0 [7.63]
036	36.0 [2.20]	160	155.7 [9.50]
040	40.0 [2.44]	200	194.6 [11.88]
050	48.6 [2.97]	250	242.3 [14.79]
060	59.1 [3.61]	315	306,1 [18.68]
080	77.8 [4.75]	400	389.1 [23.74]

C – Motor type (Align with options: D, E and F)

Code	Description
NNN	Standard motor
A10	Wheel motor
B13	Standard motor with needle bearing
L11	Wheel motor with needle bearing

D – Mounting type (Align with options: E and F)

Code	Description
B11	A2 flange; 82.5 Dia x 8 Pilot; 106.4 Dia. B.C.
B12	A2 flange; 82.5 Dia x 2.6 Pilot; 106.4 Dia. B.C.
C10	C flange; 44 Dia x 2.6 Pilot; 83 Dia. B.C.; 3/8-16 mounting
C11	C flange int.; PD44-BC83-met
C20	W flange; PD80-BC103

E – Port type (Align with options: D, F and G)

Code	Description
SO	Side port – Offset
SA	Side port – Aligned
EA	End port

OMP X Model Code

Example: OMPX-200-NNN-B11-SO-A3-A11-C-E-B-1-N-N-NN-NNN-NNN-NNN-A-NN.

A	B	C	D	E	F	G	H	J	K	L	M	N	P	R	S	T	U	V
							C			1	N			NNN	NNN		A	NN

F – Main ports thread type

Code	Description
A3	G 1/2
A8	7/8-14 UNF
A9	1/2-14 NPTF
B7	M22 x 1,5 according to ISO 6149
C1	Manifold

G – Shaft type (Align with options: C, F and K)

Code	Description
A11	Cylindrical 25 mm with 8 mm key; M8 hole in shaft end
B11	Cylindrical 1 inch with 1/4 in key; M8 hole in shaft end
B12	Cylindrical 1 inch with 1/4 in key; 1/4-20UNC hole in shaft end
B13	Cylindrical 1 inch with Woodruff key; 1/4-20UNC hole in shaft end
B14	Cylindrical 1 inch with cross hole 10.3; 1/4-20UNC hole in shaft end
B15	Cylindrical 1 inch with cross hole 8.0
C11	Spline 7/8" – 13T
C13	1 inch 6B Spline; M8 hole in shaft end
C14	1 inch 6B Spline; 1/4-20UNC hole in shaft end
E10	Tapered 28.5 mm – 1:10
F10	Tapered 1" – 1:8, WK3/16x3/4

H – Shaft seal

C	High pressure shaft seal - NBR
---	--------------------------------

J – Dust seal

Code	Description
B	Dust seal integrated in shaft seal plus seal guard
E	Dust seal integrated in shaft seal

K – Drain port (Align with options: F and G)

Code	Description
B	G1/4
D	7/16 – 20 UNF
K	M12 x 1,5 according to ISO 6149
M	No drain port due to EMD

Technical Information
Orbital Motors Type OMP X and OMR X
OMP X Model Code

Example: OMPX-200-NNN-B11-SO-A3-A11-C-E-B-1-N-N-NN-NNN-NNN-NNN-A-NN.

A	B	C	D	E	F	G	H	J	K	L	M	N	P	R	S	T	U	V
							C			1	N			NNN	NNN		A	NN

L – Check Valve

1	Yes
----------	-----

M – Brake release port

N	None
----------	------

N – Speed sensor

N	None
A	Prepared for EMD speed sensor

P – Painting

Code	Description
NN	No paint
AA	Black, 9005; Corr. class C3; Standard covering
AB	Black, 9005; Corr. class C3; Surface covering

R – Valve option

NNN	None
------------	------

S – Specific visible features

NNN	None
------------	------

T – Specific non-visible features

NNN	None
G10	Gear set – Free running

U – Packaging

A	Single pack
----------	-------------

V – Name tags: Motor and box

NN	Danfoss name tag
-----------	------------------

OMP X technical data
OMP X motor specification
OMP X motors, sizes: 25 – 100 cm³

Description		Unit	25	32	40	50	80	100
Geometric displacement		cm ³ [in]	25.0 [1.53]	32.0 [1.96]	40.0 [2.45]	48.6 [2.97]	77.8 [4.76]	97.3 [5.95]
Max. speed	cont.	min ⁻¹ (rpm)	1600	1560	1500	1230	770	615
	int. ²⁾		1800	1720	1750	1550	960	770
Max. torque ¹⁾	cont.	N·m [lb·in]	40 [355]	50 [445]	52 [460]	110 [975]	170 [1505]	210 [1860]
	int. ²⁾		50 [445]	70 [620]	90 [795]	125 [1105]	220 [1950]	260 [2300]
Max. output	cont.	kW [hp]	5.4 [7.2]	6.7 [9.0]	7.0 [9.4]	9.8 [13.1]	9.8 [13.1]	11.2 [15.0]
	int. ²⁾		7.5 [10.0]	9.3 [12.5]	11.2 [15.0]	14.0 [18.8]	14.0 [18.8]	14.0 [18.8]
Max. pressure drop	cont.	bar [psi]	115 [1670]	115 [1670]	115 [1670]	160 [2320]	160 [2320]	160 [2320]
	int. ²⁾		160 [2320]	160 [2320]	160 [2320]	200 [2900]	200 [2900]	200 [2900]
Max. starting pressure with unloaded shaft		bar [psi]	10 [145]	10 [145]	10 [145]	10 [145]	10 [145]	10 [145]
Max. oil flow	cont.	l/min [US gal/min]	40 [10.6]	50 [13.2]	60 [15.9]	60 [15.9]	60 [15.9]	60 [15.9]
	int. ²⁾		45 [11.9]	55 [14.5]	70 [18.5]	75 [19.8]	75 [19.8]	75 [19.8]
Min starting torque at max. pressure drop	cont.	N·m [lb·in]	35 [310]	45 [400]	55 [485]	155 [1370]	135 [1200]	190 [1680]
	int. ²⁾		50 [440]	65 [575]	75 [660]	190 [1680]	170 [1510]	240 [2125]

OMP X motors, sizes: 125 – 400 cm³

Description		Unit	125	160	200	250	315	400
Geometric displacement		cm ³ [in]	125 [7.65]	155.7 [9.53]	194.6 [11.91]	242.3 [14.83]	306.1 [18.73]	389.2 [23.82]
Max. speed	cont.	min ⁻¹ (rpm)	480	385	310	250	195	155
	int. ²⁾		600	480	385	310	245	190
Max. torque ¹⁾	cont.	N·m [lb·in]	270 [2390]	335 [2965]	400 [3540]	400 [3540]	400 [3540]	400 [3540]
	int. ²⁾		335 [2965]	425 [3760]	495 [4380]	490 [4335]	495 [4380]	500 [4425]
Max. output	cont.	kW [hp]	11.2 [15.0]	11.2 [15.0]	10.9 [14.5]	8.4 [11.3]	7.0 [9.4]	5.3 [7.0]
	int. ²⁾		14.0 [18.8]	14.0 [18.8]	13.7 [18.3]	10.9 [14.5]	8.8 [11.7]	6.7 [8.9]
Max. pressure drop	cont.	bar [psi]	160 [2320]	160 [2320]	155 [2250]	120 [1740]	100 [1450]	75 [1090]
	int. ²⁾		200 [2900]	200 [2900]	195 [2830]	155 [2250]	125 [1810]	95 [1380]
Max. starting pressure with unloaded shaft		bar [psi]	9 [130]	7 [100]	5 [75]	5 [75]	5 [75]	5 [75]
Max. oil flow	cont.	l/min [US gal/min]	60 [15.9]	60 [15.9]	60 [15.9]	60 [15.9]	60 [15.9]	60 [15.9]
	int. ²⁾		75 [19.8]	75 [19.8]	75 [19.8]	75 [19.8]	75 [19.8]	75 [19.8]
Min starting torque at max. pressure drop	cont.	N·m [lb·in]	240 [2125]	320 [2830]	375 [3320]	375 [3320]	380 [3365]	370 [3275]
	int. ²⁾		300 [2655]	400 [3540]	470 [4160]	480 [4250]	475 [4205]	470 [4160]

¹⁾ Maximum torque values for the different output shafts can be found in *OMP X shaft version* on page 32.

²⁾ Intermittent operation, permissible values may occur for max. 10% of every minute.

Pressure limits

Description		All sizes
Max. inlet pressure drop	Continuous	200 bar [2900 psi]
	Intermittent	225 bar [3260 psi]
Max. return pressure with drain line	Continuous	200 bar [2900 psi]
	Intermittent	225 bar [3260 psi]

Technical Information
Orbital Motors Type OMP X and OMR X
OMP X technical data
High Pressure Shaft Seal in OMP X and OMR X motors

OMP X and OMR X motors feature options with High Pressure Shaft Seal (HPS), with check valves and with or without drain connection.

HPS pressure in the drain connection

OMP X/OMR X with drain connection	OMP X/OMR X without drain connection
The shaft seal pressure equals the pressure in the drain line	The shaft seal pressure never exceeds the pressure in the return line

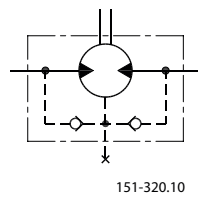
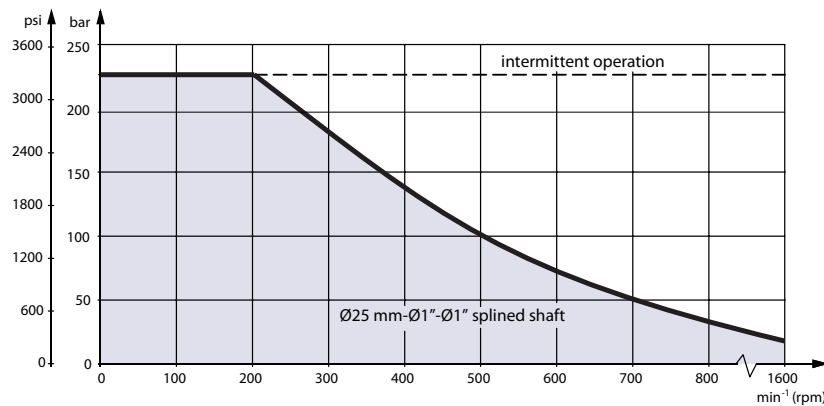
Maximum permissible shaft seal pressure

Pressure drop in OMP X motor

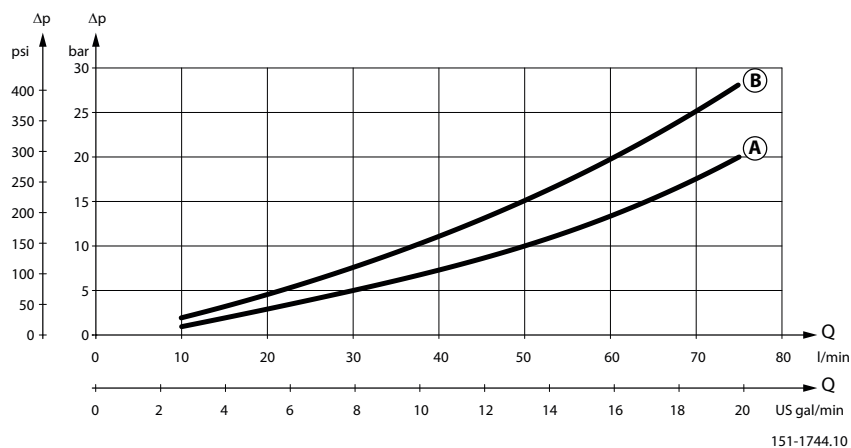
The curve applies to an unloaded motor shaft and an oil viscosity of 35 mm²/s [165 SUS]



Technical Information

Orbital Motors Type OMP X and OMR X
OMP X technical data

- A:** OMP X 50 - 400
B: OMP X 25 - 40 / OMPW X

Oil flow in drain line

Max. oil flow in the drain line at return pressure less 5-10 bar

Pressure drop	100 bar [1450 psi]		140 bar [2030 psi]	
	20 mm ² /s [100 SUS]	35 mm ² /s [165 SUS]	20 mm ² /s [100 SUS]	35 mm ² /s [165 SUS]
Max. oil flow	2.5 l/min [0.66 US gal/min]	1.8 l/min [0.78 US gal/min]	3.5 l/min [0.93 US gal/min]	2.8 l/min [0.74 US gal/min]

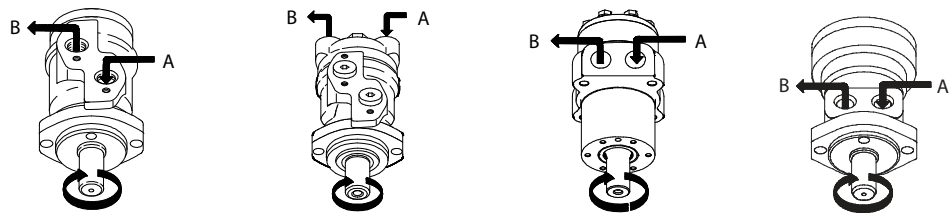
Direction of shaft rotation: clockwise

P109280

OMP X technical data
OMP X and OMR X shaft loads

The permissible radial shaft load (P_R) depends on: a distance from the point of load to the mounting flange (L), speed (n), mounting flange and shaft version.

Permissible shaft load (P_R) in N [lbf]

Mounting flange	Shaft version	Metric formula	Imperial formula
2-hole oval flange (European version)	25 mm cylindrical 28.5 mm tapered 1 in cylindrical 1 in splined	$\frac{800}{n} \cdot \frac{250000}{95 + L} \text{ N}^*$	$\frac{800}{n} \cdot \frac{2215}{3.74 + L} \text{ lbf}^*$
Square flange** 2-hole oval flange (US)	25 mm cylindrical 1 in splined	$\frac{800}{n} \cdot \frac{250000}{101 + L} \text{ N}^*$	$\frac{800}{n} \cdot \frac{2215}{3.98 + L} \text{ lbf}^*$

** For both European and US-version

* $n \geq 200 \text{ min}^{-1}$ [rpm]; $\leq 55 \text{ mm}$ [2.2 in]. $n < 200 \text{ min}^{-1}$ [rpm]; $= > P_{R\text{max}} = 8000 \text{ N}$ [1800 lbf]

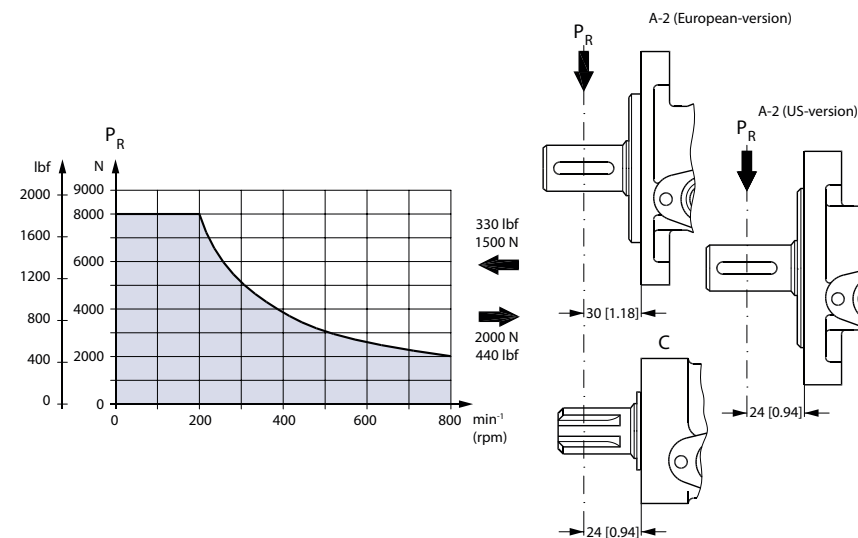

P109266

The curve shows the relation between P_R and n :

- when $l = 30 \text{ mm}$ [1.18 in] for motors with A2 (European version)
- when $l = 24 \text{ mm}$ [0.94 in] for motors with square mounting flange and A2 (US version)

For applications with special performance requirements we recommend OMP X and OMR X with the output shaft running in needle bearings.

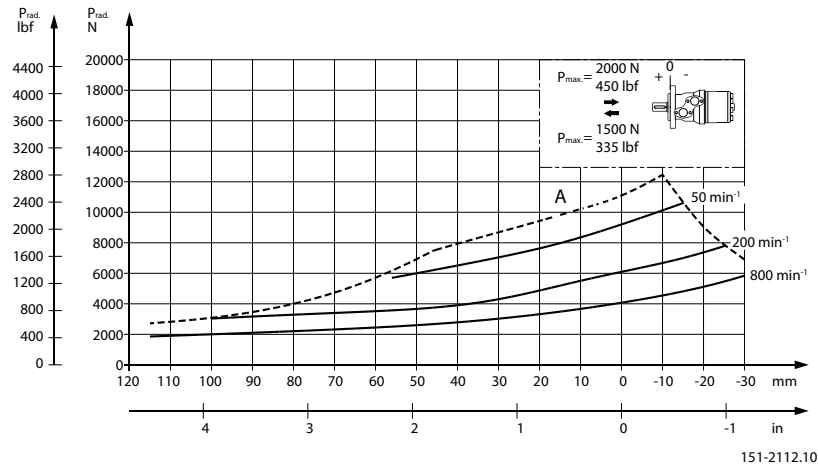
OMP X technical data
OMP X N shaft loads

The output shaft on OMP X N can be offered in needle bearings. These bearings and the recessed mounting flange allow a higher permissible radial load in comparison to OMP X motors.

The permissible radial load on the shaft is shown for different speeds as a function of the distance from the mounting flange to the point of load application.

Curve A indicates the max. radial shaft load. Any shaft load exceeding the values quoted in curve A will involve risk of breakage.

The other curves apply to a B_{10} bearing life of 2000 hours at the number of revolutions indicated by the curve letter. Mineral based hydraulic oil with a sufficient content of anti-wear additives must be used.

Bearing life calculations can be made using the explanation and formula provided in the chapter "Bearing dimensioning" in the technical information *General Orbital Motors*, **BC0000083**.

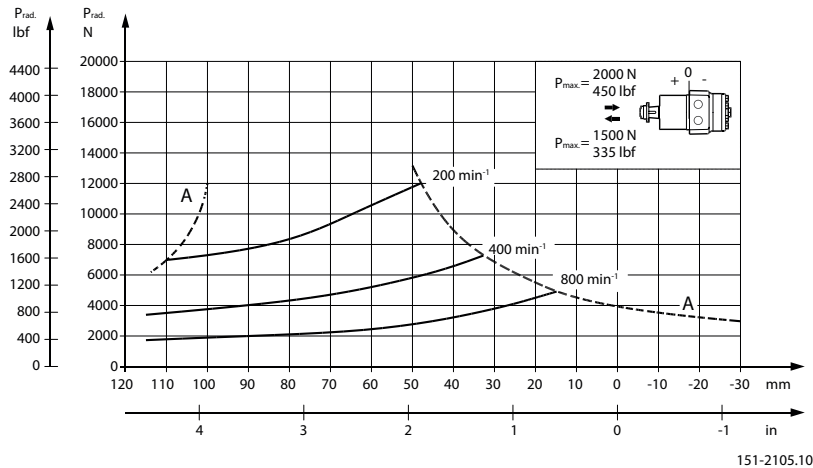
Technical Information
Orbital Motors Type OMP X and OMR X
OMP X technical data
OMPW X with slide bearings shaft loads

The output shaft on OMPW X can be offered in slide bearings similar to the other OMP X motors. The permissible higher radial load is therefore due to the recessed mounting flange moving the point of load closer to the motor bearings.

The permissible radial load on the shaft is shown for different speeds as a function of the distance from the mounting flange to the point of load application.

The curves are not based on calculations of B10 bearing life. They represent absolute limits that must not be exceeded.

Curve A indicates the max. radial shaft load. Any shaft load exceeding the values quoted in curve A will involve risk of breakage.

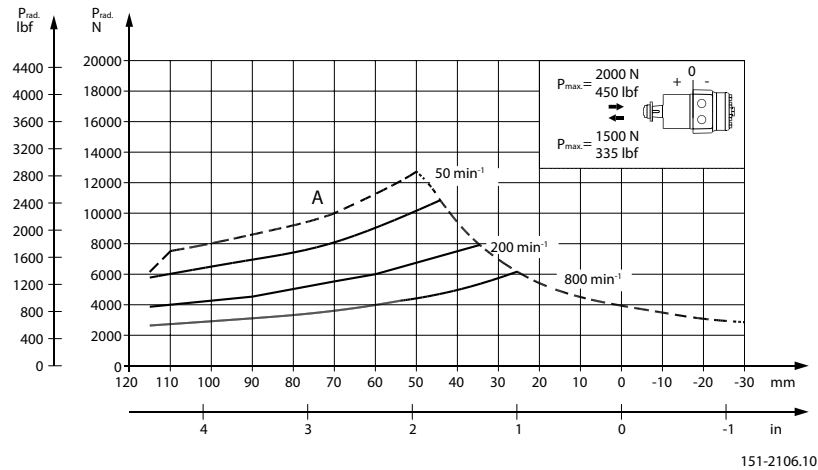
OMP X technical data
OMPW X N with needle bearing shaft loads

The output shaft on OMPW X N can be offered in needle bearings. These bearings and the recessed mounting flange allow a higher permissible radial load in comparison to OMP X motors.

The permissible radial load on the shaft is shown for different speeds as a function of the distance from the mounting flange to the point of load application.

Curve A indicates the max. radial shaft load. Any shaft load exceeding the values quoted in curve A will involve risk of breakage.

The other curves apply to a B_{10} bearing life of 2000 hours at the number of revolutions indicated by the curve letter. Mineral based hydraulic oil with a sufficient content of anti-wear additives must be used.

Bearing life calculations can be made using the explanation and formula provided in the chapter "Bearing dimensioning" in the technical information *General Orbital Motors*, **BC0000083**.

Technical Information
Orbital Motors Type OMP X and OMR X

OMP X function diagrams

Explanation of function diagram use, basis and conditions can be found in *Operating Parameters Diagrams* on page 7.

- Continuous range
- Intermittent range (max. 10% operation every minute)

Max. permissible continuous/intermittent pressure drop for the actual shaft version can be found in *OMP X technical data* on page 18.

Intermittent pressure drop and oil flow must not occur simultaneously.

OMP X 25

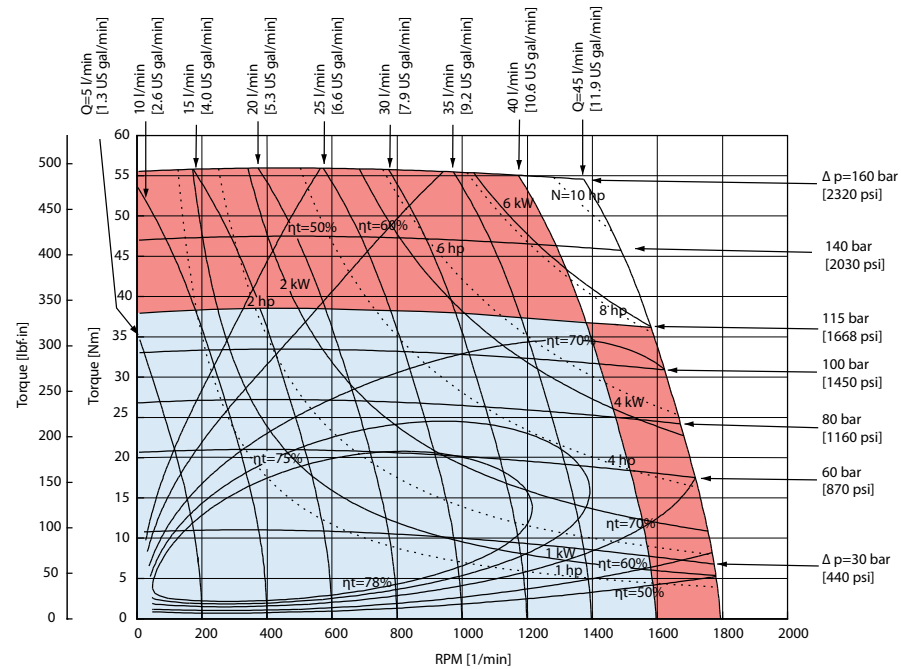

P109290

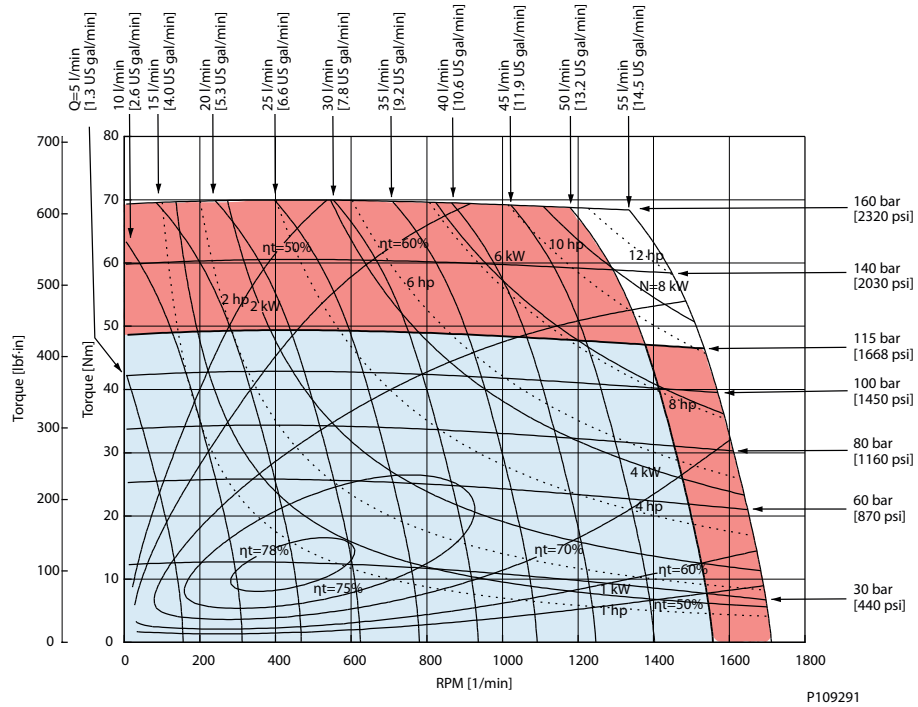
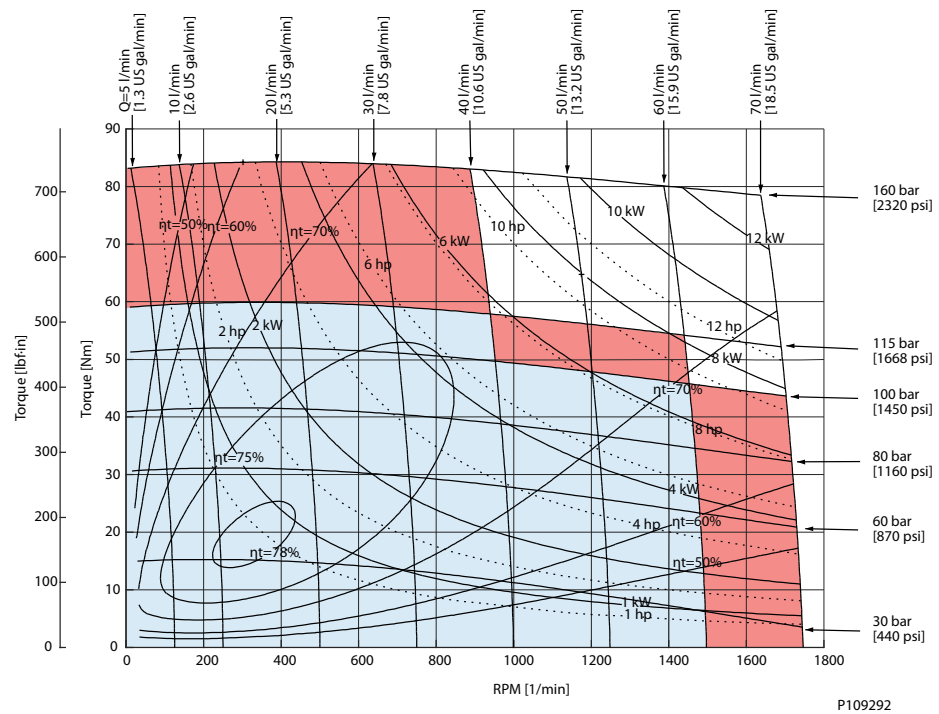
Technical Information
Orbital Motors Type OMP X and OMR X
OMP X function diagrams
OMP X 32

OMP X 40

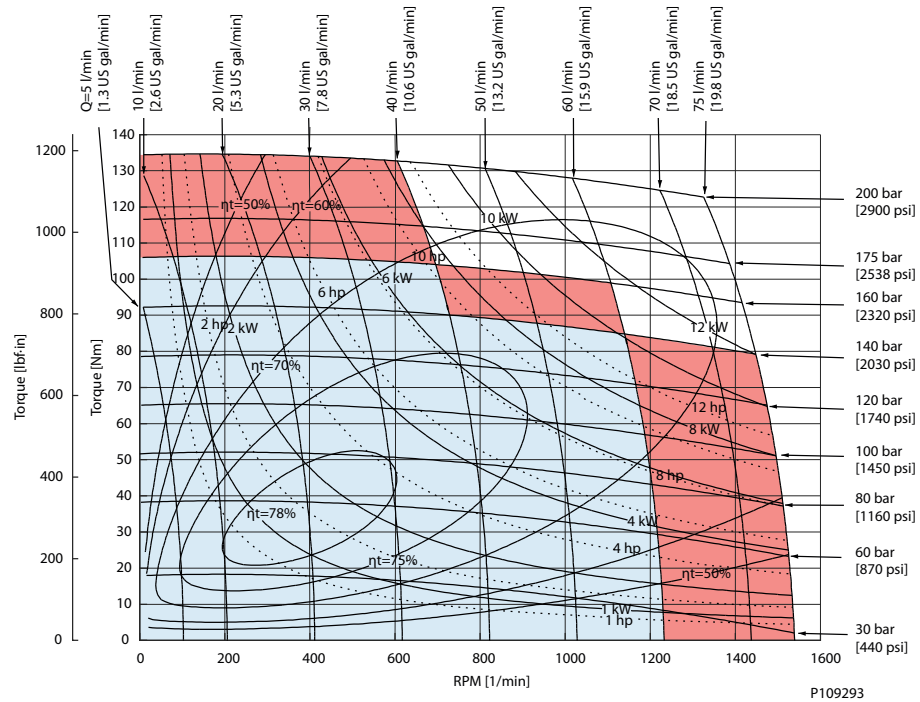
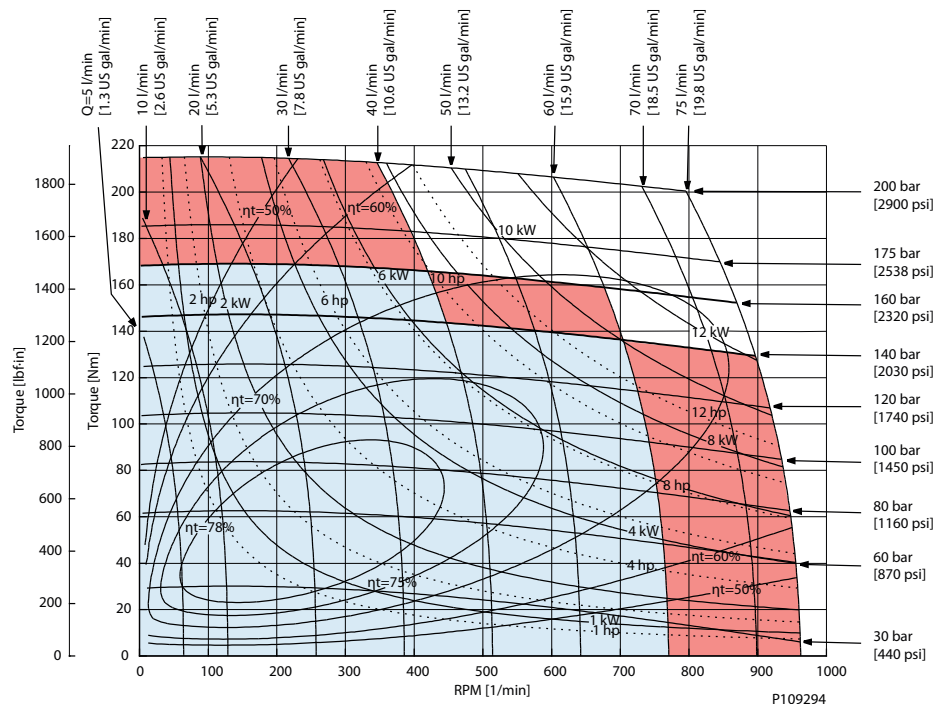
Technical Information

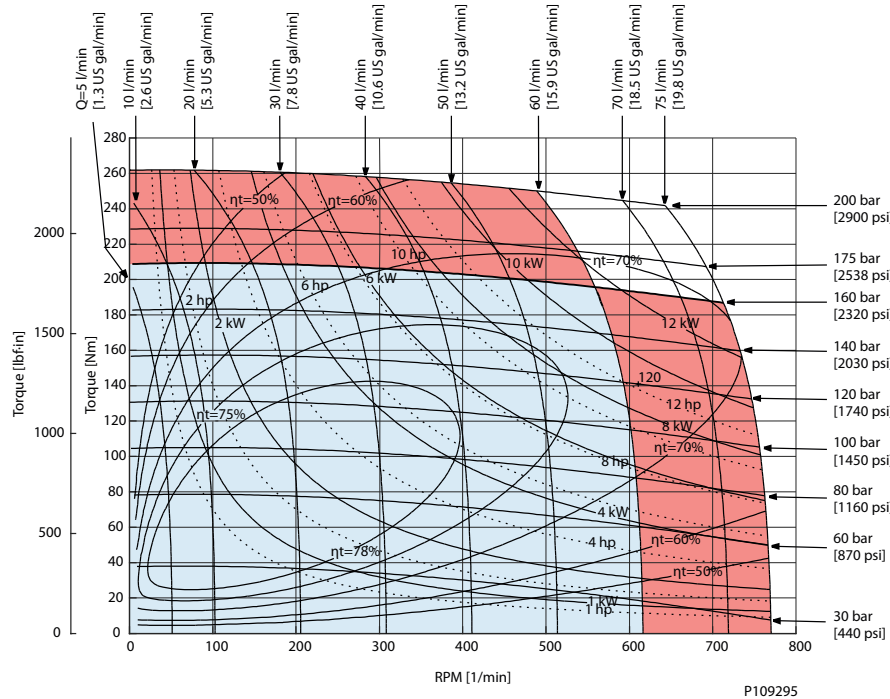
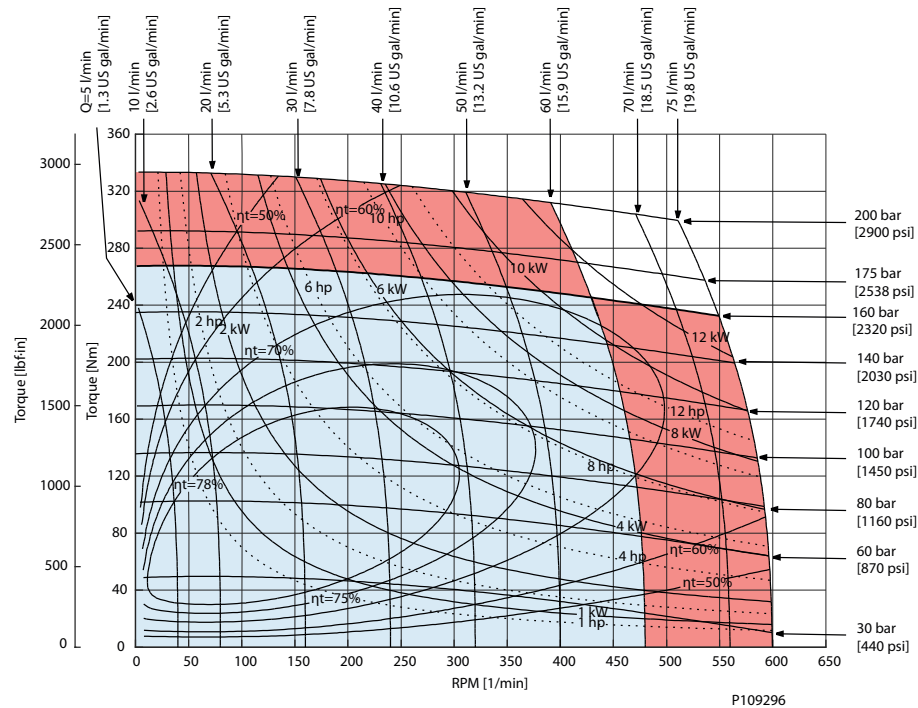
Orbital Motors Type OMP X and OMR X
OMP X function diagrams
OMP X 50

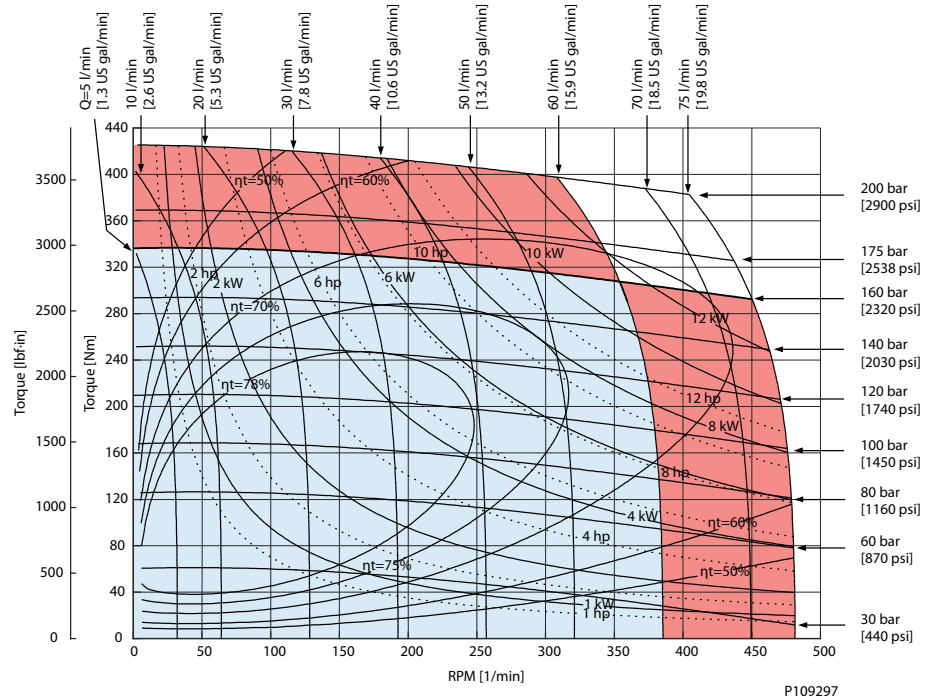
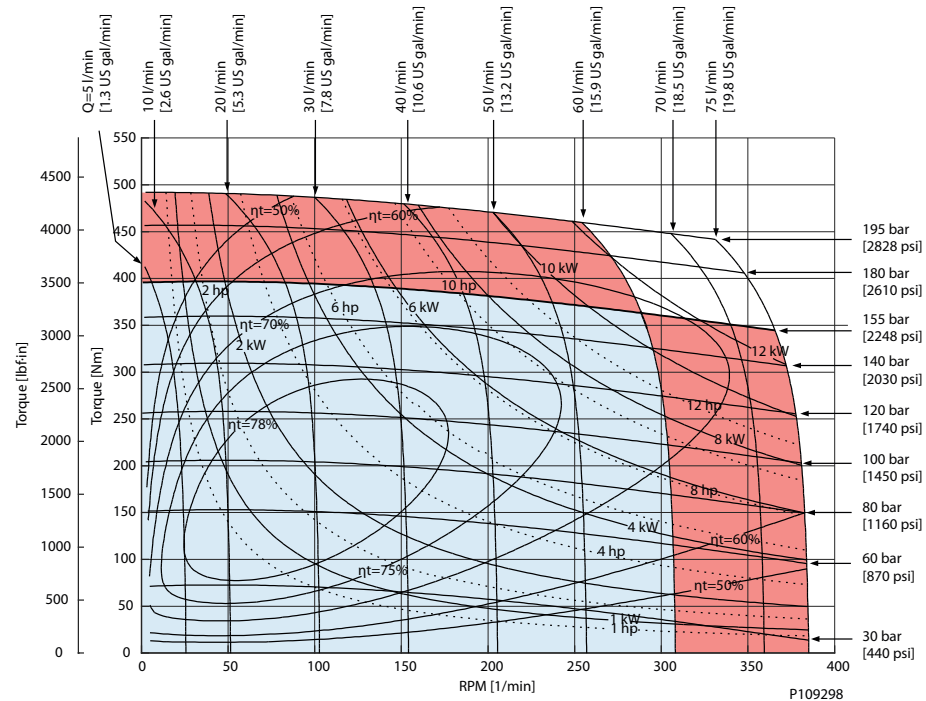
OMP X 80

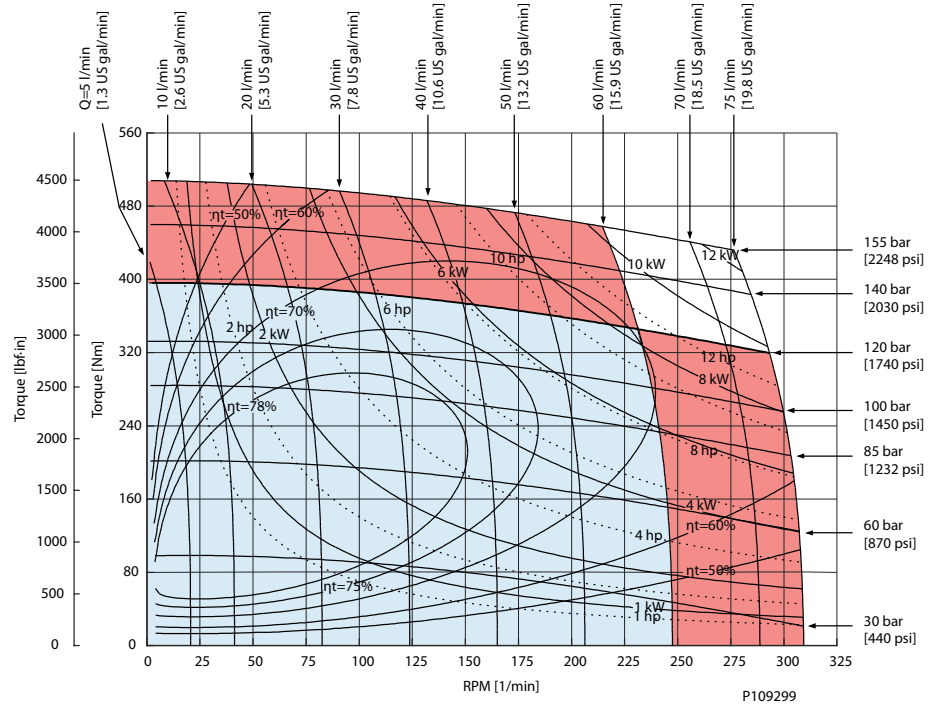
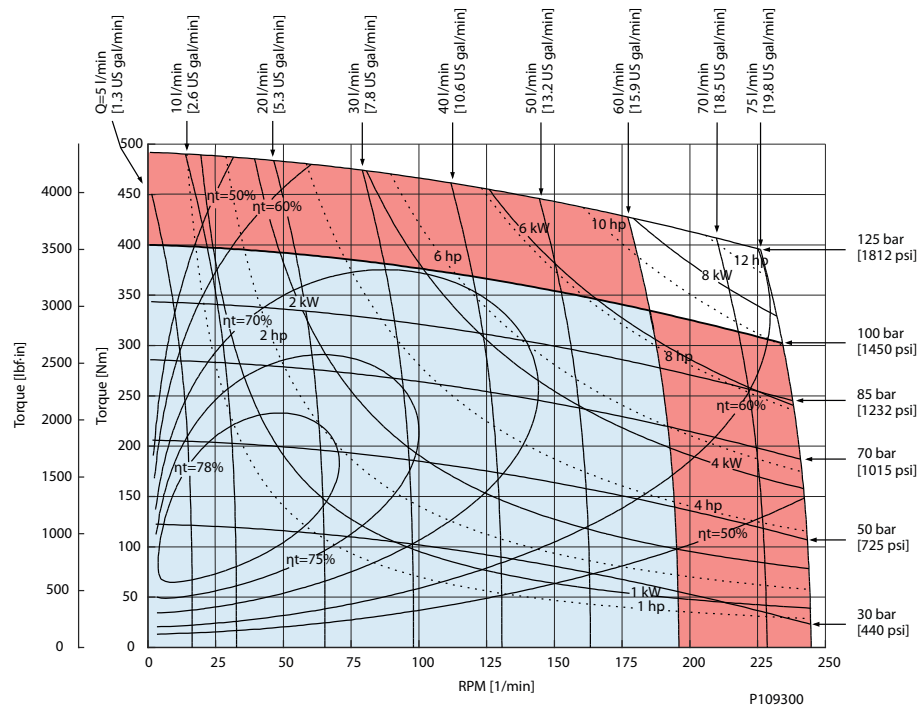
Technical Information
Orbital Motors Type OMP X and OMR X
OMP X function diagrams
OMP X 100

OMP X 125

Technical Information
Orbital Motors Type OMP X and OMR X
OMP X function diagrams
OMP X 160

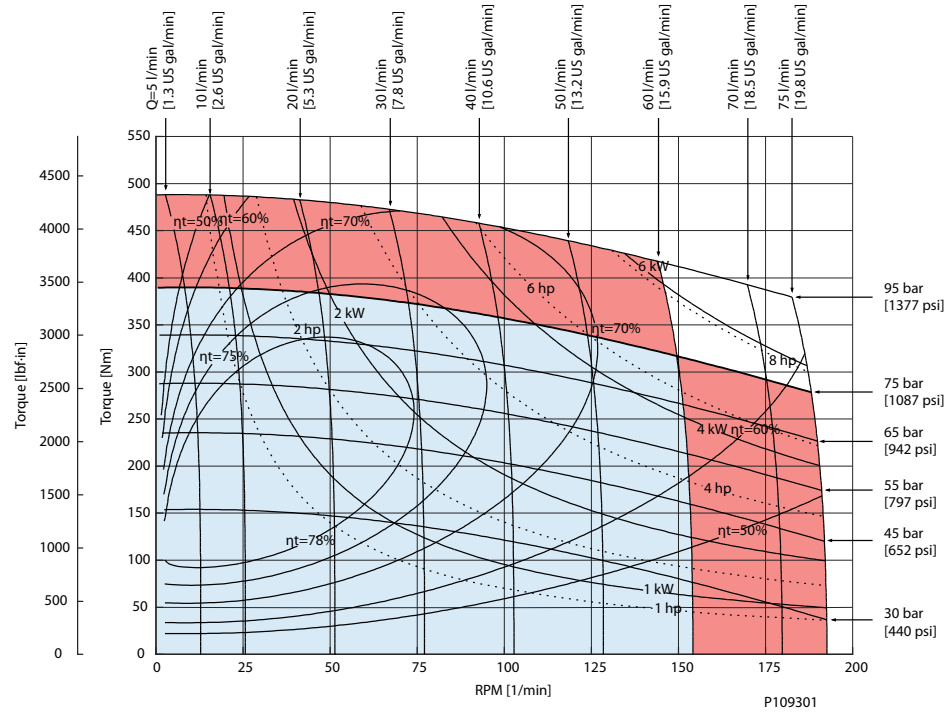
OMP X 200

Technical Information
Orbital Motors Type OMP X and OMR X
OMP X function diagrams
OMP X 250

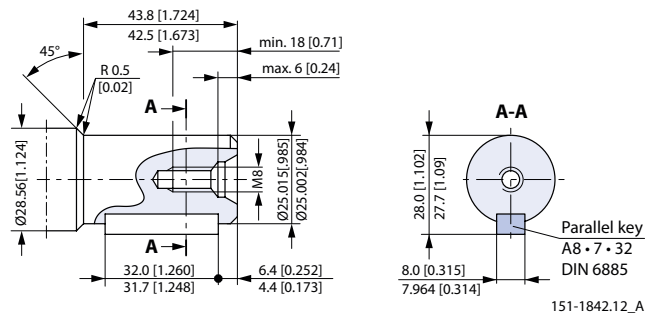
OMP X 315

Technical Information

Orbital Motors Type OMP X and OMR X
OMP X function diagrams
OMP X 400

OMP X shaft version
OMP X and OMR X shaft versions
Cylindrical shaft 25 mm; Parallel key DIN 6885

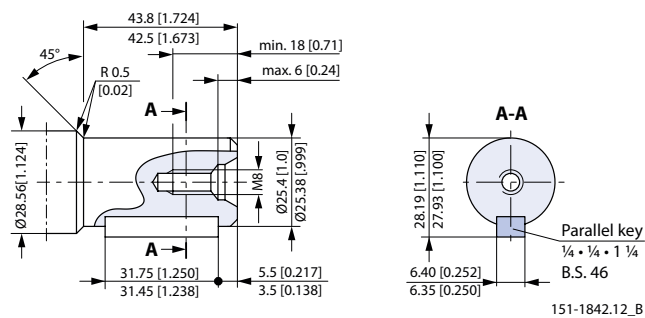
Max. cont. torque: 340 N·m [3010 lb·in]; Max. int. torque 450 N·m [3980 lb·in]

Cylindrical shaft 1 in; Parallel key B.S. 46

Max. cont. torque: 340 N·m [3010 lb·in]; Max. int. torque 450 N·m [3980 lb·in]

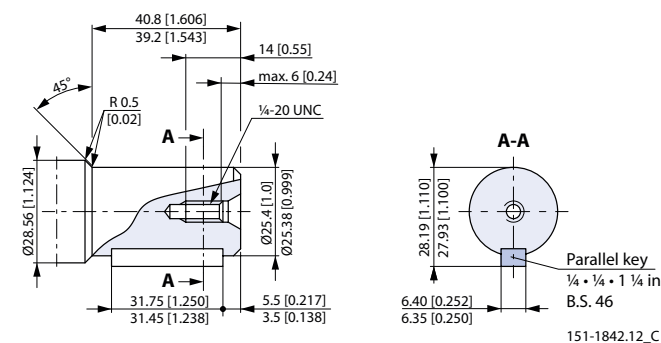
Cylindrical shaft 1 in; Parallel key B.S. 46 (US version)

Max. cont. torque: 340 N·m [3010 lb·in]; Max. int. torque 450 N·m [3980 lb·in]

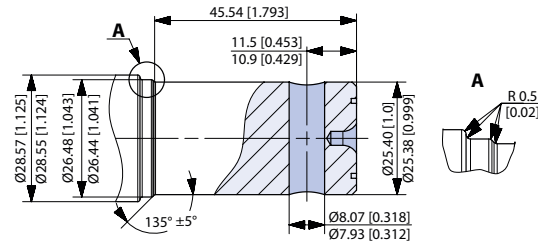
Technical Information
Orbital Motors Type OMP X and OMR X
OMP X shaft version
Cylindrical shaft 1 in; Cross hole 8 mm

Max. torque: 200 N·m [1770 lb·in]

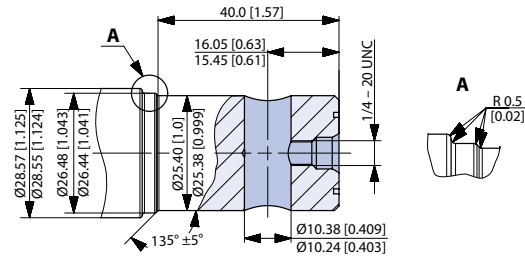
Cylindrical shaft 1 in; Cross hole 10.3 mm

Max. torque: 200 N·m [1770 lb·in]

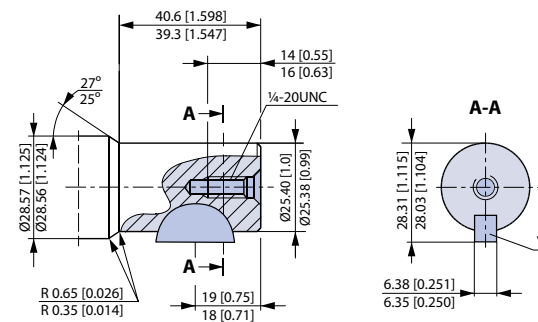
Cylindrical shaft 1 in (US version); SAE J502

1 Woodruff key 1/4 x 1 in SAE J502

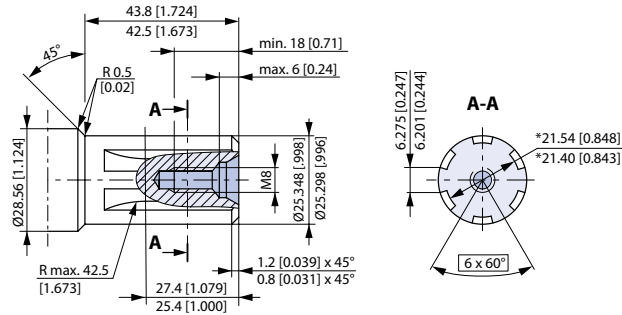
Technical Information
Orbital Motors Type OMP X and OMR X
OMP X shaft version
Splined shaft B.S. 2059 (SAE 6B)

Straight-sided, bottom fitting, dep. Fit 2, Nom. size 1 in; * Deviates from B.S. 2059 (SAE 6B)

Max. cont. torque: 400 N·m [3540 lb·in]

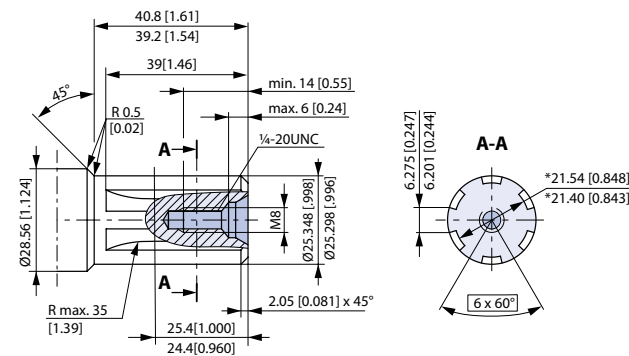
Splined shaft B.S. 2059 (SAE 6B); US version

Straight-sided, bottom fitting, deep. Fit 2; Nom. size 1 in, *Deviates from B.S. 2059 (SAE 6B)

Max. cont. torque 400 N·m [3540 lb·in]

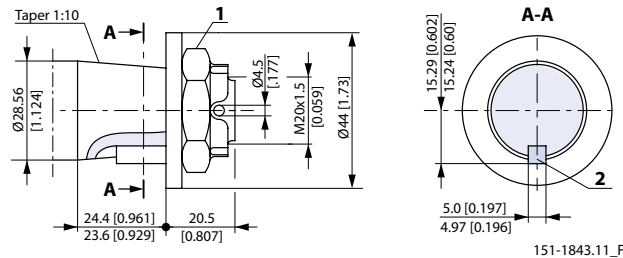
Tapered shaft (taper 1:10); Parallel key DIN 6885

1. DIN 937 NV 30; Tightening torque: 100 ± 10 N·m [885 ± 88.5 lb·in]

2. Parallel key B5 · 5 · 14; DIN 6885

Max. cont. torque: 400 N·m [3540 lb·in]

Technical Information
Orbital Motors Type OMP X and OMR X
OMP X port thread versions
Main port thread versions
Main ports overview

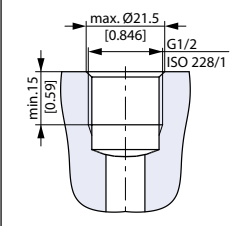
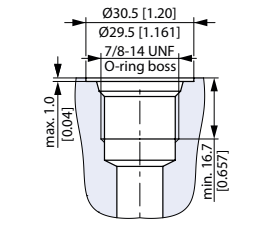
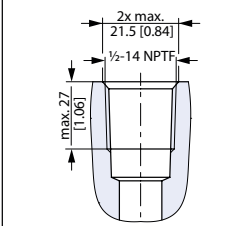
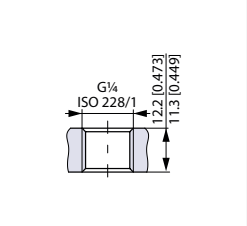
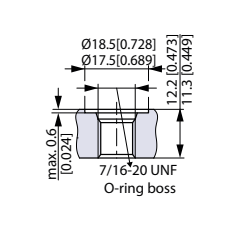
G ISO 228/1 – G1/2	UNF 7/8–14 UNF O-ring boss	NPTF 1/2–14 NPTF	G drain ISO 228/1 – G1/4	UNF drain 7/16–20 UNF O-ring boss
				

OMP X manifold mount

For OMP X manifold mounting versions please see the dimension drawings for given OMP X motors listed below:

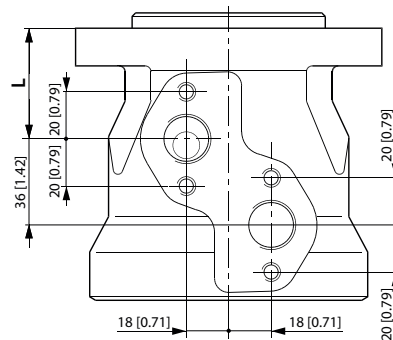

For **L** dimension please see the tables in the topics below:

- [EU version side port offset with 2-hole oval mounting flange \(A2-flange\)](#) on page 36
- [EU version end port with 2-hole oval mounting flange \(A2-flange\)](#) on page 37
- [EU version OMPW X and OMPW X N motors wheel type](#) on page 38
- [US version side port offset with 2-hole oval mounting flange \(A2-flange\)](#) on page 39
- [US version side port aligned with 2-hole oval mounting flange \(A2-flange\)](#) on page 40
- [US version side port aligned with square mounting flange \(C-flange\)](#) on page 41

Technical Information

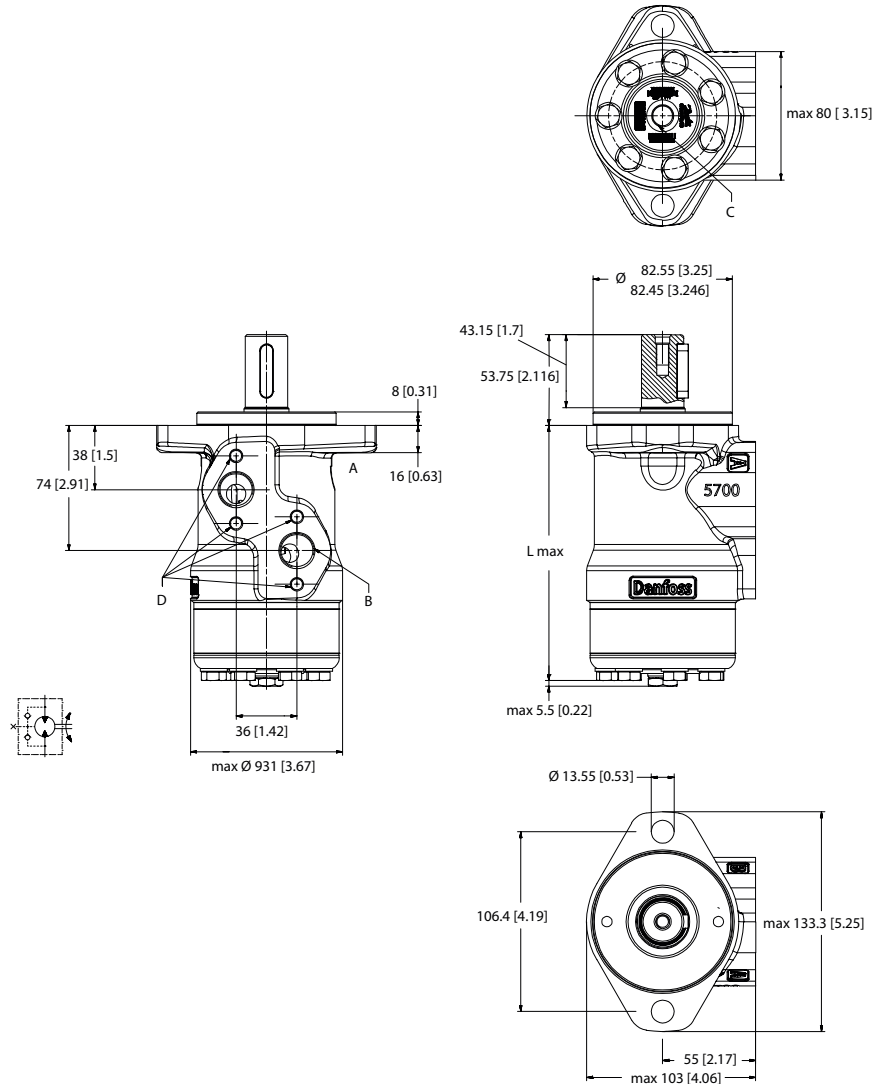
Orbital Motors Type OMP X and OMR X
OMP X dimensions
EU version side port offset with 2-hole oval mounting flange (A2-flange)

P109273

Port connections:

- A, B** Main ports: G 1/2; min 15 mm [0.59 in] deep
- C** Drain port: G 1/4; 11.5 mm [0.45 in]
- D** Thread: M8; 13 mm [0.51 in] deep

Size	25	32	40	50	60	80	100	125	160	200	250	315	400
L max. mm [in]	130.8 [5.15]	131.9 [5.22]	133.2 [5.25]	133.2 [5.25]	134.6 [5.3]	137.1 [5.4]	139.7 [5.5]	143.4 [5.65]	147.5 [5.81]	152.7 [6.02]	159.2 [6.27]	167.6 [6.6]	178.7 [7.04]

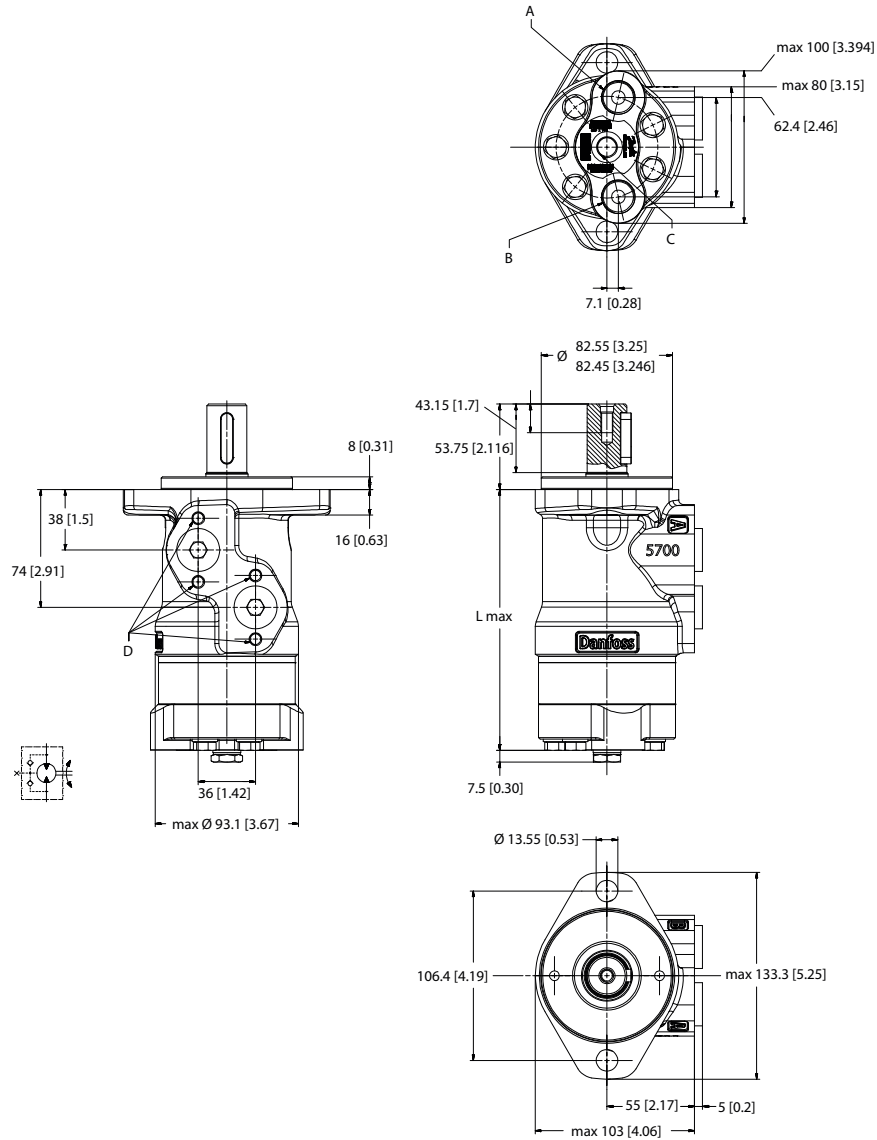
Technical Information
Orbital Motors Type OMP X and OMR X
OMP X dimensions
EU version end port with 2-hole oval mounting flange (A2-flange)

P109275

Port connections:

- A, B** Main ports: G 1/2; min 15 mm [0.59 in] deep
C Drain port: G 1/4; 12 mm [0.47 in] deep
D Thread: M8; 13 mm [0.51 in] deep

Size	40	50	80	100	160	200	250	315	400
L max. mm [in]	146.8 [5.78]	146.8 [5.78]	150.7 [5.94]	153.3 [6.04]	161.1 [6.35]	166.3 [6.55]	172.8 [6.81]	181.2 [7.14]	192.2 [7.58]

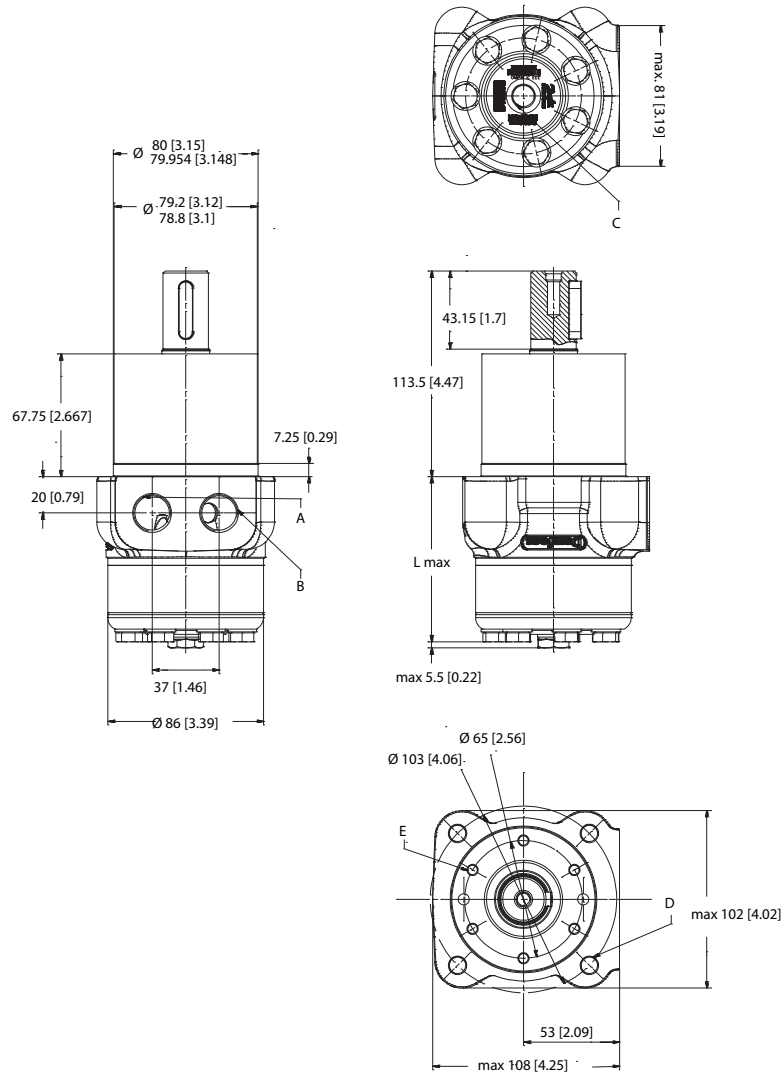
Technical Information
Orbital Motors Type OMP X and OMR X
OMP X dimensions
EU version OMPW X and OMPW X N motors wheel type

P109267

Port connections:

- A, B** Main ports: G 1/2; min 15 mm [0.59 in] deep
- C** Drain port: G 1/4; 12 mm [0.47 in] deep
- D** Thread: M10, 20 mm [0.78 in] deep

Size	50	80	100	125	160	200	250	315	400
L max. mm [in]	73.4 [2.89]	77.3 [3.05]	79.9 [3.15]	83.7 [3.30]	87.7 [3.46]	92.9 [3.66]	99.4 [3.92]	107.8 [4.25]	118.9 [4.69]

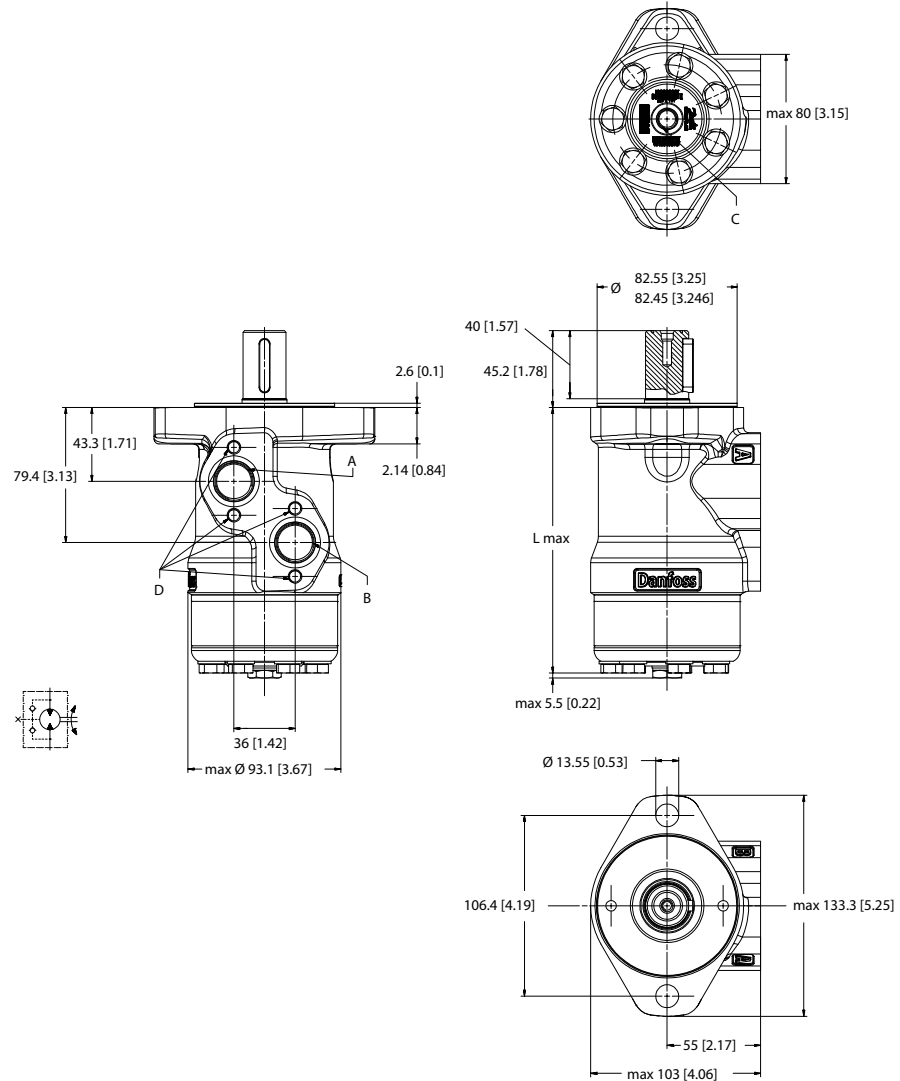
Technical Information
Orbital Motors Type OMP X and OMR X
OMP X dimensions
US version side port offset with 2-hole oval mounting flange (A2-flange)

P109277

Port connections:

- A, B** Main ports: 7/8 - 14 UNF; min. 16.7 mm [0.66 in] deep
- C** Drain port: 7/16 - 20 UNF; 11.5 mm [0.45 in] deep
- D** Thread: M8; 13 mm [0.51 in] deep

Size	25	32	40	50	80	100	160	200	315	400
L max. mm [in]	136.2 [5.37]	137.3 [5.41]	138.6 [5.46]	138.6 [5.46]	142.5 [5.62]	145.1 [5.72]	152.9 [6.02]	158.1 [6.82]	173.0 [6.82]	184.1 [7.25]

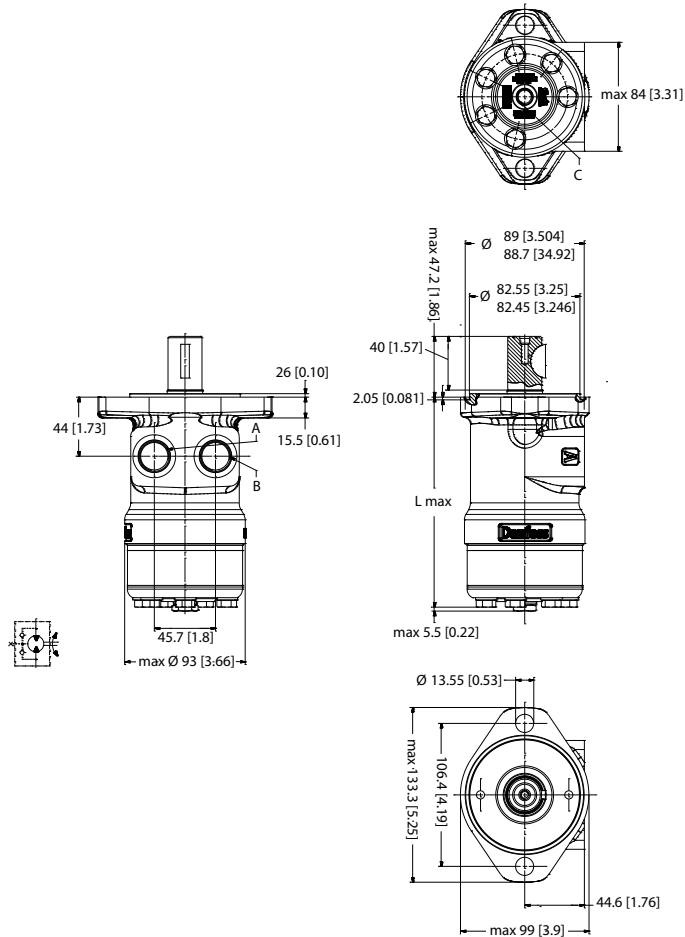
Technical Information
Orbital Motors Type OMP X and OMR X
OMP X dimensions
US version side port aligned with 2-hole oval mounting flange (A2-flange)

P109282

Port connections:
A, B Main ports: 7/8 - 14 UNF; min. 16.7 mm [0.66 in] deep

C Drain port: 7/16 - 20 UNF; 11.5 mm [0.45 in] deep

Size	36	50	80	100	125	160	200	250	315	400
L max. mm [in]	137.9 [5.43]	138.6 [5.46]	142.5 [5.62]	145.1 [5.72]	148.8 [5.86]	152.9 [6.02]	158.1 [6.23]	164.6 [6.49]	173 [6.82]	184.1 [7.25]

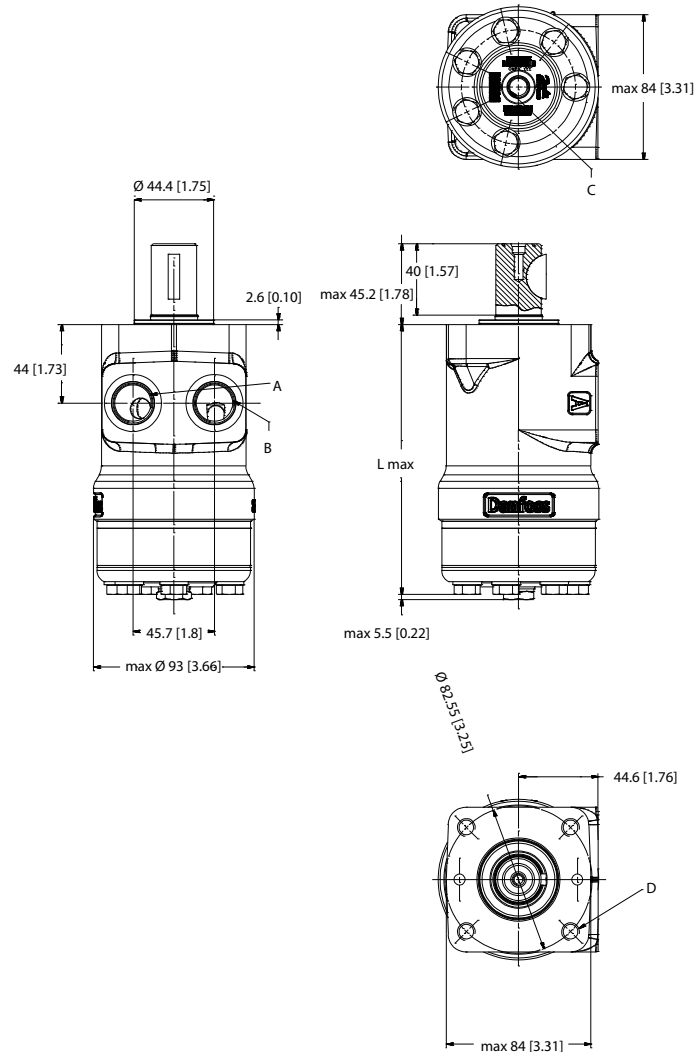
Technical Information
Orbital Motors Type OMP X and OMR X
OMP X dimensions
US version side port aligned with square mounting flange (C-flange)

P109283

Port connections:

- A, B** Main ports: 7/8 - 14 UNF; min. 11.5 mm [0.45 in] deep
- C** Drain port: 7/16 - 20 UNF; 11.5 mm [0.45 in] deep
- D** Thread: 3/8 - 16 UNC; 15 mm [0.59 in] deep

Size	36	50	80	100	125	160	200	250	315	400
L max.	137.9	138.6	142.5	145.1	148.8	152.9	158.1	164.6	173	184.1
mm [in]	[5.43]	[5.46]	[5.62]	[5.72]	[5.86]	[6.02]	[6.23]	[6.49]	[6.82]	[7.25]

OMR X configuration versions overview with codes numbers

The following tables show the different versions configuration codes.

- OMR X standard motors:
 - [Side port offset 2-hole oval mounting flange \(A2 flange\)](#) on page 42
 - [Side port aligned with 2-hole oval mounting flange \(A2 flange\)](#) on page 43
 - [Side port aligned with square mounting flange \(C flange\)](#) on page 44
- OMR X N motors with needle bearings: [Side port offset 2-hole oval mounting flange \(A2-flange\)](#) on page 45

If the desired OMR X could not be found please use the [OMR X Model Code](#) on page 46.

OMR X standard motors

For OMR X motors with a configuration which is not available in the code number tables please use the model code number system in the [OMR X Model Code](#) on page 46 to specify the OMR X motor on detail.

Side port offset 2-hole oval mounting flange (A2 flange)

Configuration code numbers are set according to OMR X motor mounting flange type.

Configuration codes A1 – A7 description

Pilot dia.	Ø 82.5 mm [3.25 in]						
Bolt circle dia.	Ø 106.4 mm [4.20 in]						
Conf. code	A2	A1	A3	A4	A5	A6	A7
Shaft	Cyl. Ø25 mm	Cyl. Ø25 mm	Cyl. 1 in	Cyl. 1 in	Splined 1 in	Splined 1 in	Tap. Ø28.5 mm
Main port	G1/2	G1/2	G1/2	7/8 -14 UNF	G1/2	7/8 -14 UNF	G1/2
Drain port	G1/4	G1/4	G1/4	7/16-20 UNF	G1/4	7/16-20 UNF	G1/4
Port type	End	Side offset					
Check valve	Yes						
Shaft seal	High pressure shaft seal						
Designation	Main type designation: OMR X						

Code numbers for OMR X: A1 — A7

Code	Displacement								
	50	80	100	125	160	200	250	315	375
A1	11185537	11186671	11186674	11186655	11186658	11186665	11186667	11186652	11185531
A2	11185473	11185474	11186645	11185468	11185469	11186642	11185471	11185467	11186644
A3	11185558	11185560	11185562	11185548	11185549	11185551	11185554	11185545	11185556
A4	11185488	11185489	11185490	11185483	11185484	11185485	11185486	11185482	11185487
A5	11185584	11185585	11185588	11185567	11185570	11185573	11185576	11185564	11185580
A6	11185497	11185498	11185499	11185492	11185493	11185494	11185495	11185491	11185496
A7	11185609	11185610	11185611	11185604	11185605	11185606	11185607	11185603	11185608

Technical Information
Orbital Motors Type OMR X and OMR X
OMR X configuration versions overview with codes numbers
Side port aligned with 2-hole oval mounting flange (A2 flange)

Configuration codes **B1–B5** description according to OMR X motor mounting flange type: Side port aligned with 2-hole oval mounting flange (A2 flange).

Configuration codes B1 – B5 description

Pilot diameter	Ø 82.5 mm [3.25 in]				
Bolt circle dia.	Ø 106.4 mm [4.20 in]				
Configuration code	B2	B1	B3	B4	B5
Shaft	Cylindrical 1 in	Cylindrical 1 in	Splined 1 in	Cyl. 1 in, CH8	Cyl. 1 in, CH10.3
Main port size	1/2–14 NPTF	7/8–14 UNF			
Drain port size	7/16–20 UNF				
Port type	Side port aligned				
Check valve	Yes				
Shaft seal	High pressure shaft seal				
Designation	Main type designation: OMR X				

Code numbers for OMR X: B1 – B5

Code	Displacement										
	36	50	80	100	125	160	200	250	315	375	400
B1	—	11186162	11186163	11186164	11186157	11186158	11186159	11186160	11186156	—	11186161
B2	—	—	11186189	11186190	—	11186185	11186186	11186187	—	—	11186188
B3	—	—	11186154	11186155	11186151	—	11186152	—	11186150	—	11186153
B4	83062987	83062988	83062989	83062990	83062991	83063012	83063013	83063014	83063015	83063016	83063017
B5	83063057	83063058	83063059	83063060	83063061	83063082	83063083	83063084	83063085	83063086	83063087

OMR X configuration versions overview with codes numbers
Side port aligned with square mounting flange (C flange)

Configuration codes **C1–C4** description according to OMR X motor mounting flange type (C flange, 4 x 3/8-16 UNC mounting threads).

Configuration codes C1 – C4 description

Pilot diameter	Ø 44.4 mm [1.75 in]			
Bolt circle dia.	Ø 82.5 mm [3.25 in]			
Configuration code	C2	C1	C3	C4
Shaft	Cylindrical 1 in	Cylindrical 1 in	Cyl. 1 in, CH8	Cyl. 1 in, CH10.3
Main port size	1/2–14 NPTF	7/8–14 UNF		
Drain port size	7/16–20 UNF			
Port type	Side port aligned			
Check valve	Yes			
Shaft seal	High pressure shaft seal			
Designation	Main type designation: OMR X			

Code numbers for OMR X: C1 – C4

Code	Displacement										
	36	50	80	100	125	160	200	250	315	375	400
C1	–	11186146	11186147	11186148	11186646	11186647	11186143	11186144	11185479	–	11186145
C2	–	11186197	–	11186198	–	11186193	11186194	11186195	–	–	11186196
C3	83063079	83063080	83063081	83063102	83063103	83063104	83063105	83063106	83063108	83063109	83063110
C4	83063731	83063742	11186149	83063743	83063744	83063745	83063746	83063747	83063748	83063749	83063750

Technical Information
Orbital Motors Type OMP X and OMR X
OMR X configuration versions overview with codes numbers
OMR X N motors with needle bearings
Side port offset 2-hole oval mounting flange (A2-flange)

Configuration code **D1** description according to OMR X N motor mounting flange: Side port offset with 2-hole oval mounting flange (A2-flange).

Configuration code D1 description

Configuration code	D1
Pilot diameter	Ø 82.5 mm [3.25 in]
Bolt circle diameter	Ø 106.4 mm [4.20 in]
Shaft	Cylindrical Ø 25 mm [Dia 0.984 in]
Main port size	G1/2
Drain port size	G1/4
Port type	Side offset
Check valve	Yes
Shaft seal	High pressure shaft seal
Main type designation	OMR X N

Code numbers for D1

Code	Displacement							
	50	80	125	160	200	250	315	375
D1	11185526	11185601	11185594	11185595	11185596	11185598	11185593	11185599

OMR X Model Code

The coding system has been developed to identify the configuration options for the OMP X motors. The model code begins with the motor family and the remaining fields are filled in to configure the motor with the desired features, all fields must be filled in. *Example: OMRX-200-NNN-B11-SO-A3-A11-C-E-B-1-N-N-NN-NNN-NNN-NNN-A-NN.*

A	B	C	D	E	F	G	H	J	K	L	M	N	P	R	S	T	U	V
							C			1	N			NNN	NNN		A	NN

A – Main motor family

OMRX	OMR X motor series
-------------	--------------------

B – Motor displacement

Code	Displacement, cm ³ /rev [in ³ /rev]
036	36.9 [2.25]
050	51.6 [3.15]
080	80.3 [4.90]
100	99.8 [6.09]
125	124.1 [7.57]
160	155.4 [9.48]
200	198.2 [12.09]
250	248.1 [15.14]
315	310.1 [18.92]
375	363.5 [22.18]
400	390.7 [23.84]

C – Motor type (Align with options: D, E and F)

Code	Description
NNN	Standard motor
B13	Standard motor with needle bearing

D – Mounting type (Align with options: E and F)

Code	Description
B11	A2 flange; 82.5 Dia x 8 Pilot; 106.4 Dia B.C.
B12	A2 flange; 82.5 Dia x 2.6 Pilot; 106.4 Dia B.C.
C10	C4 flange; 44 Dia x 2.6 Pilot; 83 Dia B.C.; 3/8-16 mounting

E – Port type (Align with options: D, F and G)

Code	Description
SO	Side port – Offset
SA	Side port – Aligned
EA	End port

Technical Information
Orbital Motors Type OMP X and OMR X
OMR X Model Code

Example: OMRX-200-NNN-B11-SO-A3-A11-C-E-B-1-N-N-NN-NNN-NNN-NNN-A-NN.

A	B	C	D	E	F	G	H	J	K	L	M	N	P	R	S	T	U	V
							C			1	N			NNN	NNN		A	NN

F – Main ports thread type

Code	Description
A3	G 1/2
A8	7/8-14 UNF
A9	1/2-14 NPTF
B7	M22 x 1,5 according to ISO 6149
C1	Manifold

G – Shaft type (Align with options: C, F and K)

Code	Description
A11	Cylindrical 25 mm with 8 mm key; M8 hole in shaft end
B11	Cylindrical 1 inch with 1/4 in key; M8 hole in shaft end
B12	Cylindrical 1 inch with 1/4 in key; 1/4-20UNC hole in shaft end
B13	Cylindrical 1 inch with Woodruff key; 1/4-20UNC hole in shaft end
B14	Cylindrical 1 inch with cross hole 10.3; 1/4-20UNC hole in shaft end
B15	Cylindrical 1 inch with cross hole 8.0
C11	Spline 7/8" – 13T
C13	1 inch 6B Spline; M8 hole in shaft end
C14	1 inch 6B Spline; 1/4-20UNC hole in shaft end
E10	Tapered 28.5 mm – 1:10
F10	Tapered 1" – 1:8, WK3/16x3/4

H – Shaft seal

C	High pressure shaft seal - NBR
---	--------------------------------

J – Dust seal

Code	Description
B	Dust seal integrated in shaft seal plus seal guard
E	Dust seal integrated in shaft seal

K – Drain port (Align with options: F and G)

Code	Description
B	G1/4
D	7/16 – 20 UNF
K	M12 x 1,5 according to ISO 6149
M	No drain port due to EMD

OMR X Model Code

Example: OMRX-200-NNN-B11-SO-A3-A11-C-E-B-1-N-N-NN-NNN-NNN-NNN-A-NN.

A	B	C	D	E	F	G	H	J	K	L	M	N	P	R	S	T	U	V
							C			1	N			NNN	NNN		A	NN

L – Check Valve

1	Yes
----------	-----

M – Brake release port

N	None
----------	------

N – Speed sensor

N	None
A	Prepared for EMD speed sensor

P – Painting

Code	Description
NN	No paint
AA	Black, 9005; Corr. class C3; Standard covering
AB	Black, 9005; Corr. class C3; Surface covering

R – Valve option

NNN	None
------------	------

S – Specific visible features

NNN	None
------------	------

T – Specific non-visible features

NNN	None
------------	------

U – Packaging

A	Single pack
----------	-------------

V – Name tags: Motor and box

NN	Danfoss name tag
-----------	------------------

Technical Information

Orbital Motors Type OMP X and OMR X
OMR X technical data
OMR X motor specification

 OMR X motors, sizes: 50 – 160 cm³

Description		Unit	50	80	100	125	160
Geometric displacement		cm ³ [in]	51.6 [3.16]	80.3 [4.91]	99.8 [6.11]	124.1 [7.57]	155.4 [9.48]
Max. speed	cont.	min ⁻¹ (rpm)	775	750	600	475	385
	int. ²⁾		970	940	750	600	480
Max. torque ¹⁾	cont.	N·m [lb·in]	100 [890]	215 [1900]	275 [2435]	330 [2920]	380 [3365]
	int. ²⁾		120 [1060]	235 [2080]	300 [2655]	360 [3185]	435 [3580]
Max. output	cont.	kW [hp]	7.0 [9.4]	14.0 [18.8]	14.0 [18.8]	14.0 [18.8]	12.6 [16.9]
	int. ²⁾		8.8 [11.7]	15.8 [21.1]	17.5 [23.5]	17.5 [23.5]	15.8 [21.1]
Max. pressure drop	cont.	bar [psi]	150 [2175]	200 [2900]	200 [2900]	200 [2900]	180 [2610]
	int. ²⁾		175 [2540]	225 [3260]	225 [3260]	225 [3260]	215 [3120]
Max. starting pressure with unloaded shaft		bar [psi]	10 [145]	10 [145]	10 [145]	10 [145]	10 [145]
Max. oil flow	cont.	l/min [US gal/min]	40 [10.6]	60 [15.9]	60 [15.9]	60 [15.9]	60 [15.9]
	int. ²⁾		50 [13.2]	75 [19.8]	75 [19.8]	75 [19.8]	75 [19.8]
Min starting torque at max. pressure drop	cont.	N·m [lb·in]	85 [750]	190 [1680]	230 [2035]	295 [2610]	335 [2965]
	int. ²⁾		100 [890]	215 [1900]	255 [2255]	335 [2965]	400 [3540]

 OMR X motors, sizes: 200 – 400 cm³

Description		Unit	200	250	315	375	400
Geometric displacement		cm ³ [in]	198.2 [12.09]	248.1 [15.14]	310.1 [18.92]	363.5 [22.18]	390.7 [23.84]
Max. speed	cont.	min ⁻¹ (rpm)	305	240	195	165	155
	int. ²⁾		380	300	245	205	195
Max. torque ¹⁾	cont.	N·m [lb·in]	400 [3540]	400 [3540]	400 [3540]	390 [3450]	400 [3540]
	int. ²⁾		480 [4250]	540 [4780]	550 [4870]	550 [4870]	480 [4250]
Max. output	cont.	kW [hp]	10.5 [14]	8.8 [11.7]	7.0 [9.4]	5.6 [7.5]	4.9 [6.6]
	int. ²⁾		13.1 [17.5]	10.5 [14.1]	8.9 [11.9]	.8 [10.5]	6.1 [8.2]
Max. pressure drop	cont.	bar [psi]	150 [2175]	125 [1815]	100 [1450]	80 [1160]	70 [1015]
	int. ²⁾		195 [2830]	170 [2465]	140 [2030]	115 [1670]	90 [1305]
Max. starting pressure with unloaded shaft		bar [psi]	10 [145]	7 [100]	7 [100]	7 [100]	5 [75]
Max. oil flow	cont.	l/min [US gal/min]	60 [15.9]	60 [15.9]	60 [15.9]	60 [15.9]	60 [15.9]
	int. ²⁾		75 [19.8]	75 [19.8]	75 [19.8]	75 [19.8]	75 [19.8]
Min starting torque at max. pressure drop	cont.	N·m [lb·in]	350 [3100]	370 [3275]	370 [3275]	335 [2965]	325 [2875]
	int. ²⁾		460 [4070]	500 [4425]	515 [4560]	480 [4250]	420 [3715]

¹⁾ Maximum torque values for the different output shafts can be found in *OMP X shaft version* on page 32.

²⁾ Intermittent operation: the permissible values may occur for max. 10% of every minute.

Pressure limits

Description		All sizes
Max. inlet pressure drop	Continuous	200 bar [2900 psi]
	Intermittent	225 bar [3260 psi]
Max. return pressure with drain line	Continuous	200 bar [2900 psi]
	Intermittent	225 bar [3260 psi]

OMR X technical data
High Pressure Shaft Seal in OMP X and OMR X motors

OMP X and OMR X motors feature options with High Pressure Shaft Seal (HPS), with check valves and with or without drain connection.

HPS pressure in the drain connection

OMP X/OMR X with drain connection	OMP X/OMR X without drain connection
The shaft seal pressure equals the pressure in the drain line	The shaft seal pressure never exceeds the pressure in the return line

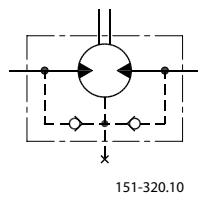
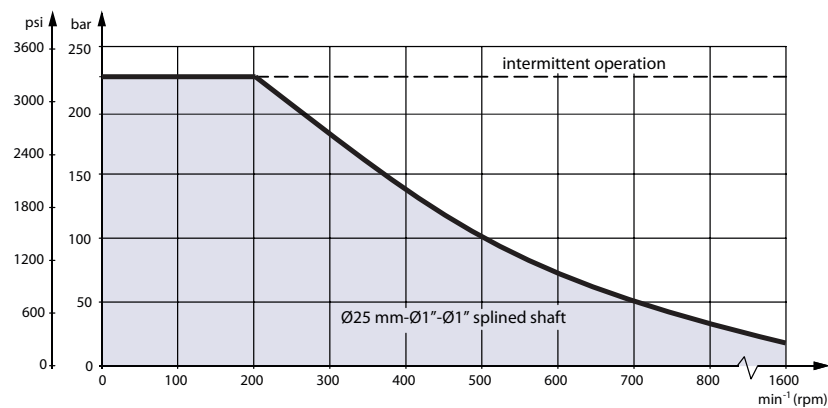
Maximum permissible shaft seal pressure

Pressure drop in OMR X motor

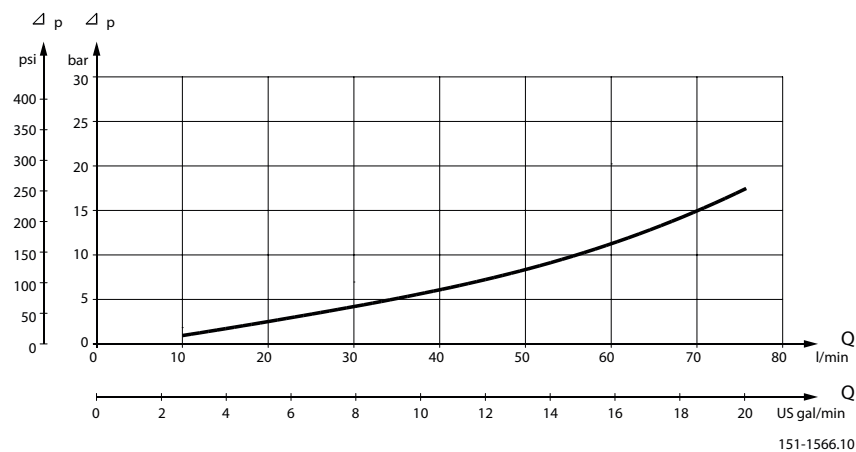
The curve applies to an unloaded motor shaft and an oil viscosity of 35 mm²/s [165 SUS]



Technical Information

Orbital Motors Type OMP X and OMR X
OMR X technical data
Oil flow in drain line

Max. oil flow in the drain line at return pressure less 5-10 bar

Pressure drop	100 bar [1450 psi]		140 bar [2030 psi]	
	20 mm ² /s [100 SUS]	35 mm ² /s [165 SUS]	20 mm ² /s [100 SUS]	35 mm ² /s [165 SUS]
Max. oil flow	2.5 l/min [0.66 US gal/min]	1.8 l/min [0.78 US gal/min]	3.5 l/min [0.93 US gal/min]	2.8 l/min [0.74 US gal/min]

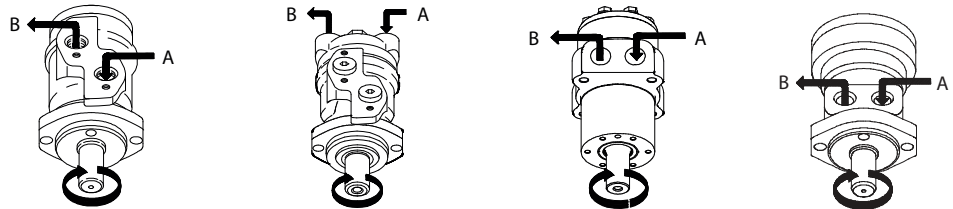
Direction of shaft rotation: clockwise

P109280

Technical Information
Orbital Motors Type OMP X and OMR X
OMR X technical data
OMP X and OMR X shaft loads

The permissible radial shaft load (P_R) depends on: a distance from the point of load to the mounting flange (L), speed (n), mounting flange and shaft version.

Permissible shaft load (P_R) in N [lbf]

Mounting flange	Shaft version	Metric formula	Imperial formula
2-hole oval flange (European version)	25 mm cylindrical 28.5 mm tapered 1 in cylindrical 1 in splined	$\frac{800}{n} \cdot \frac{250000}{95 + L} \cdot N^*$	$\frac{800}{n} \cdot \frac{2215}{3.74 + L} \cdot \text{lbf}^*$
Square flange** 2-hole oval flange (US)	25 mm cylindrical 1 in splined	$\frac{800}{n} \cdot \frac{250000}{101 + L} \cdot N^*$	$\frac{800}{n} \cdot \frac{2215}{3.98 + L} \cdot \text{lbf}^*$

** For both European and US-version

* $n \geq 200 \text{ min}^{-1}$ [rpm]; $\leq 55 \text{ mm}$ [2.2 in]. $n < 200 \text{ min}^{-1}$ [rpm]; $\Rightarrow P_{R\text{max}} = 8000 \text{ N}$ [1800 lbf]

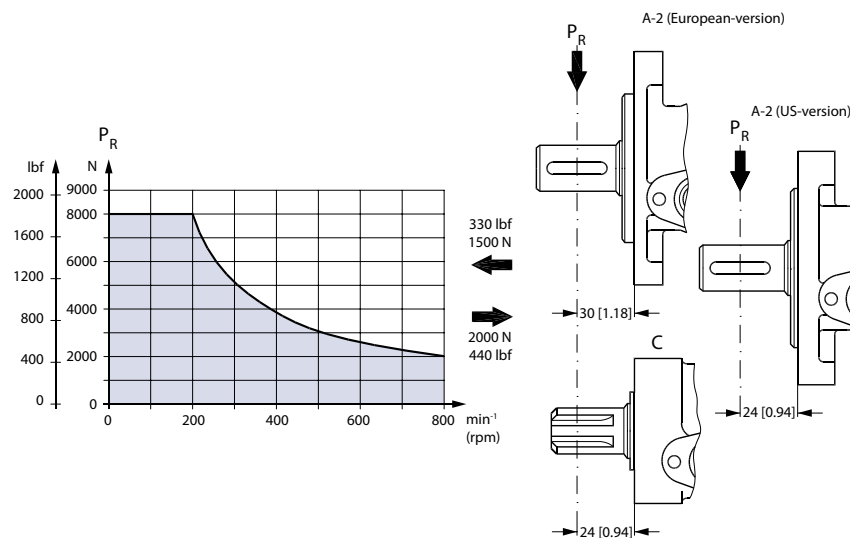

P109266

The curve shows the relation between P_R and n:

- when $l = 30 \text{ mm}$ [1.18 in] for motors with A2 (European version)
- when $l = 24 \text{ mm}$ [0.94 in] for motors with square mounting flange and A2 (US version)

For applications with special performance requirements we recommend OMP X and OMR X with the output shaft running in needle bearings.

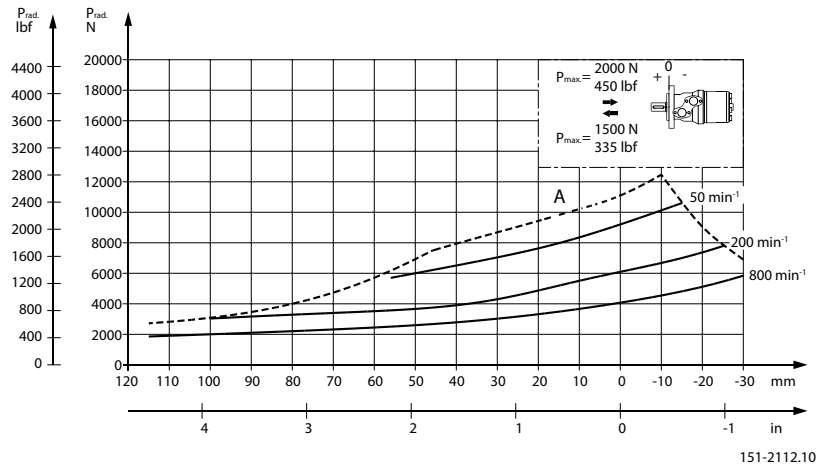
Technical Information
Orbital Motors Type OMP X and OMR X
OMR X technical data
OMR X N with needle bearings shaft loads

The output shaft on OMR X N runs in needle bearings. These bearings and the recessed mounting flange allow a higher permissible radial load in comparison to OMR X motors with slide bearings.

The permissible radial load on the shaft is shown for different speeds as a function of the distance from the mounting flange to the point of load application.

Curve A indicates the max. radial shaft load. Any shaft load exceeding the values quoted in curve A will involve risk of breakage.

The other curves apply to a B_{10} bearing life of 2000 hours at the number of revolutions indicated by the curve letter. Mineral based hydraulic oil with a sufficient content of anti-wear additives must be used.

Bearing life calculations can be made using the explanation and formula provided in the chapter "Bearing dimensioning" in the technical information *General Orbital Motors*, **BC0000083**.

OMR X function diagrams

Performance graphs for OMR X motors according to the displacement. Blue area shows continuous range and red area shows intermittent range (max. 10% operation every minute).

Explanation of function diagram use, basis and conditions can be found in [Operating Parameters Diagrams](#) on page 7.

Intermittent pressure drop and oil flow must not occur simultaneously. Max. permissible continuous/intermittent pressure drop for the actual shaft version can be found in [OMR X technical data](#) on page 49.

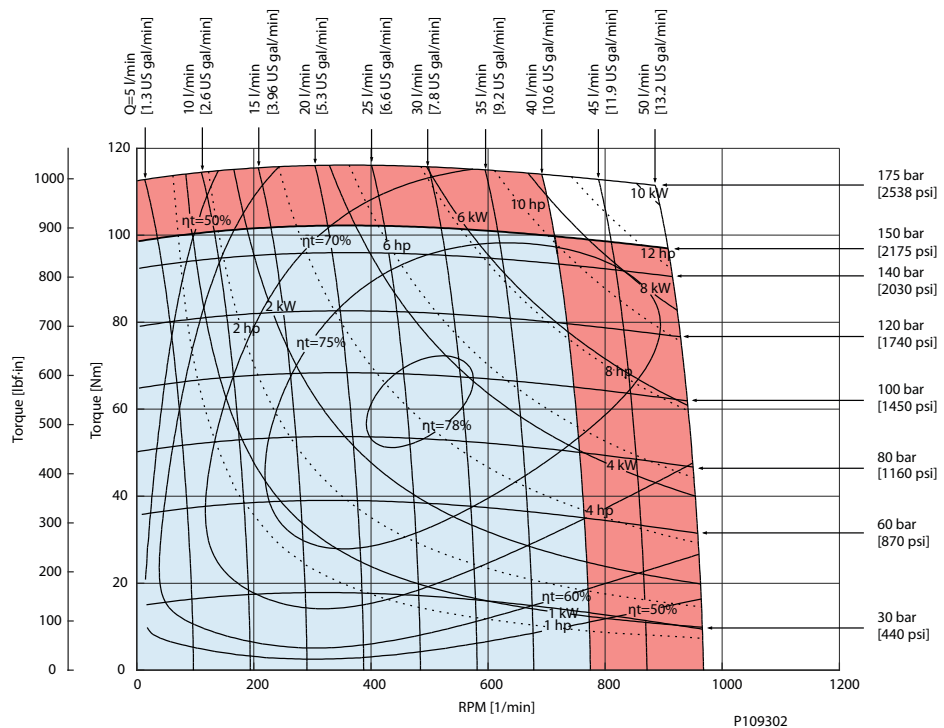
OMR X 50

Technical Information

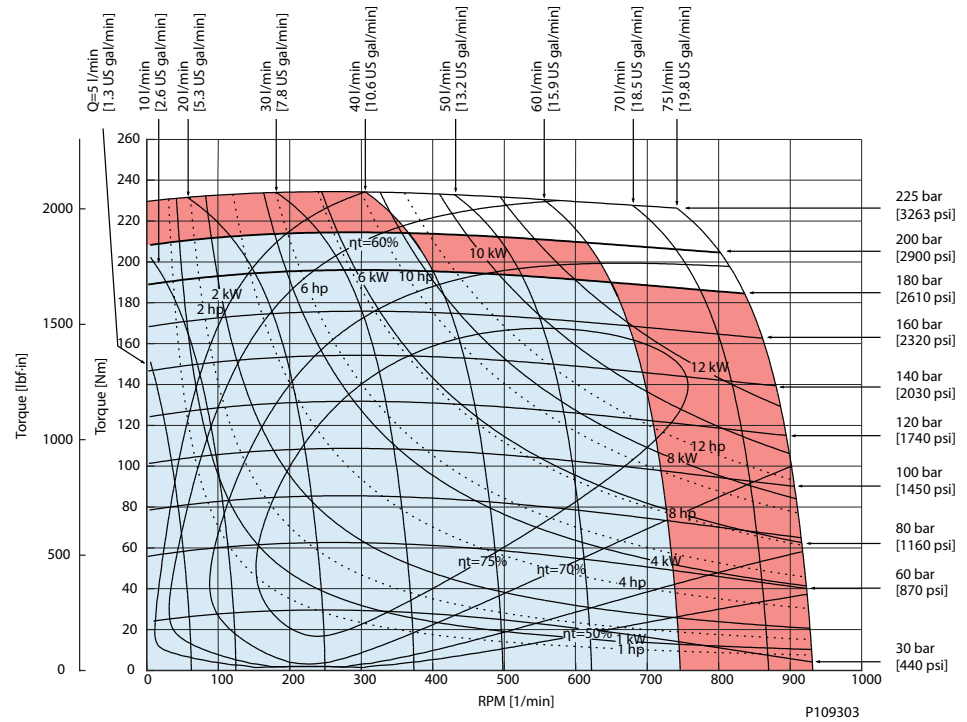
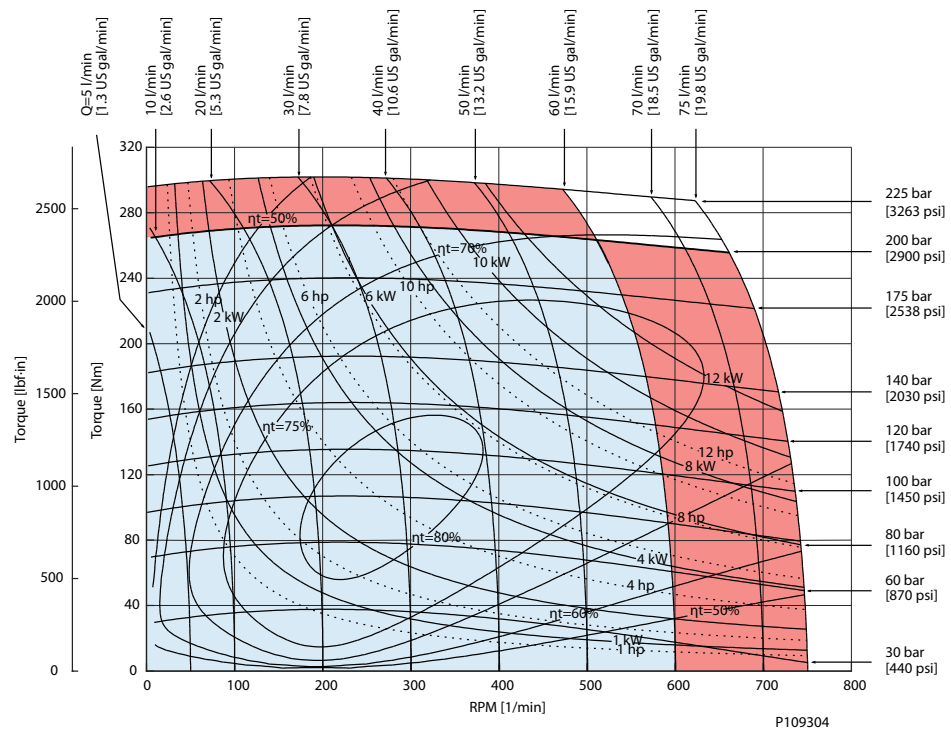
Orbital Motors Type OMP X and OMR X
OMR X function diagrams
OMR X 80

OMR X 100

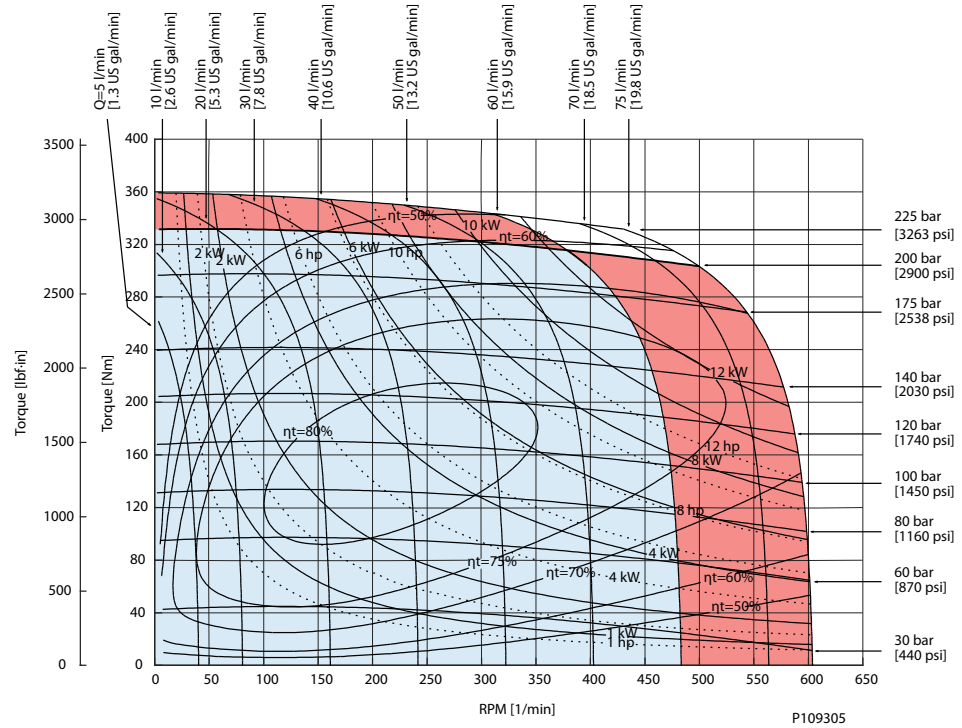
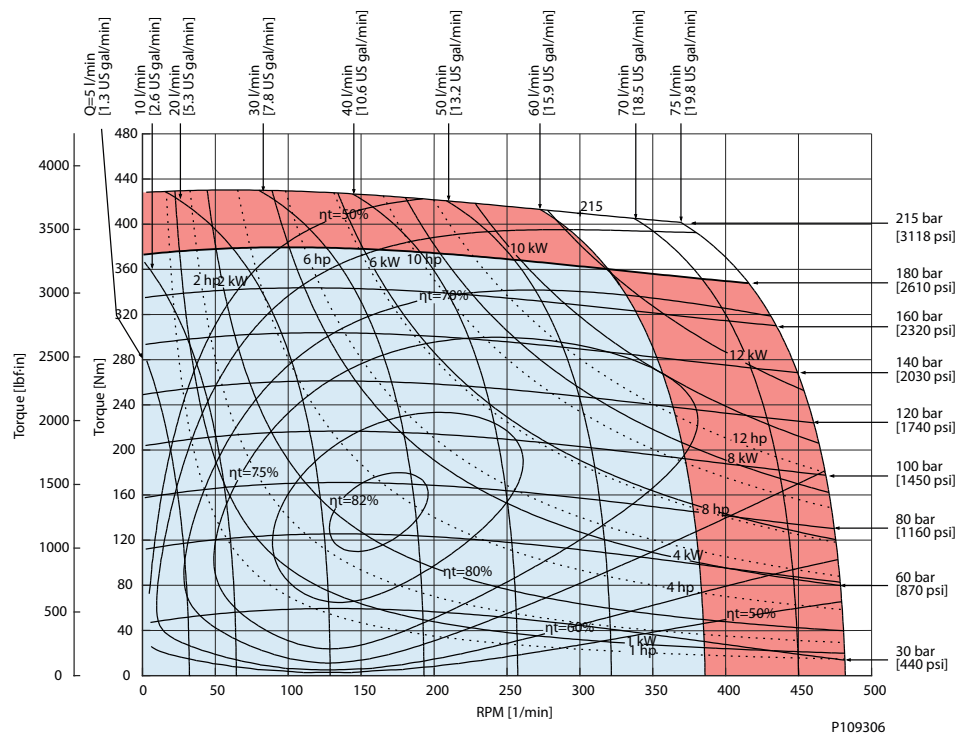
Technical Information

Orbital Motors Type OMP X and OMR X
OMR X function diagrams
OMR X 125

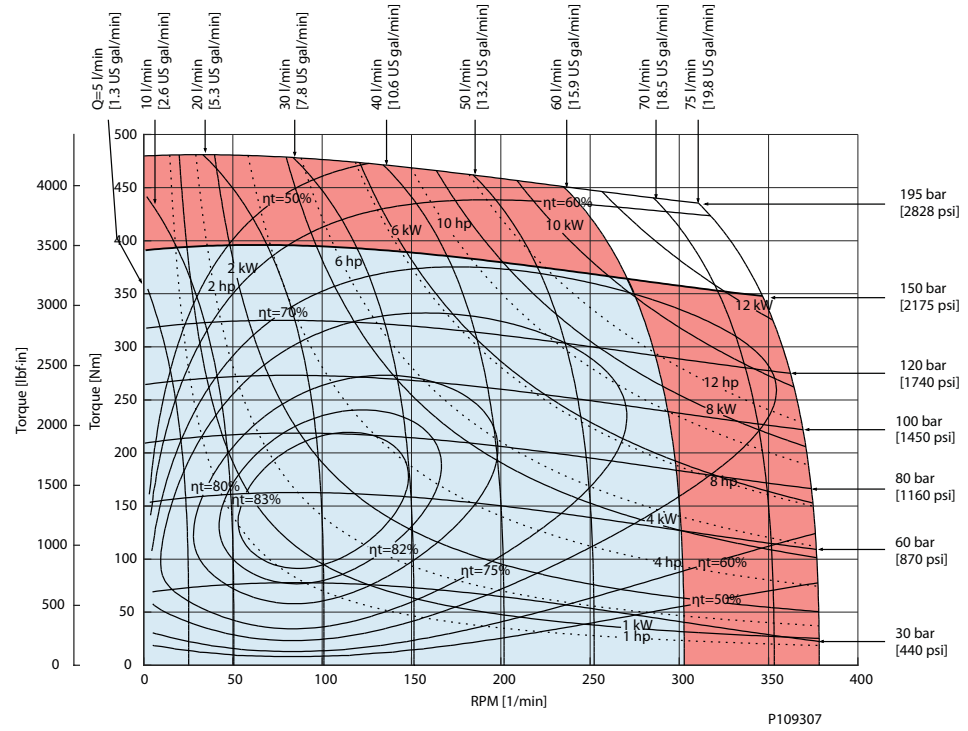
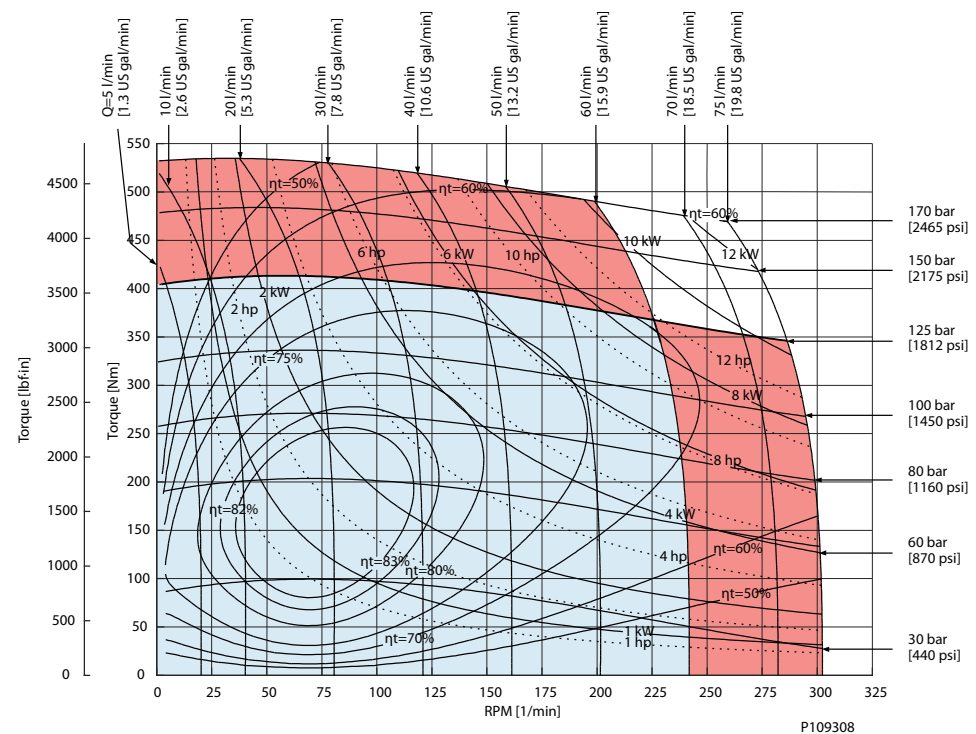
OMR X 160

Technical Information

Orbital Motors Type OMP X and OMR X
OMR X function diagrams
OMR X 200

OMR X 250

Technical Information
Orbital Motors Type OMP X and OMR X

OMR X function diagrams

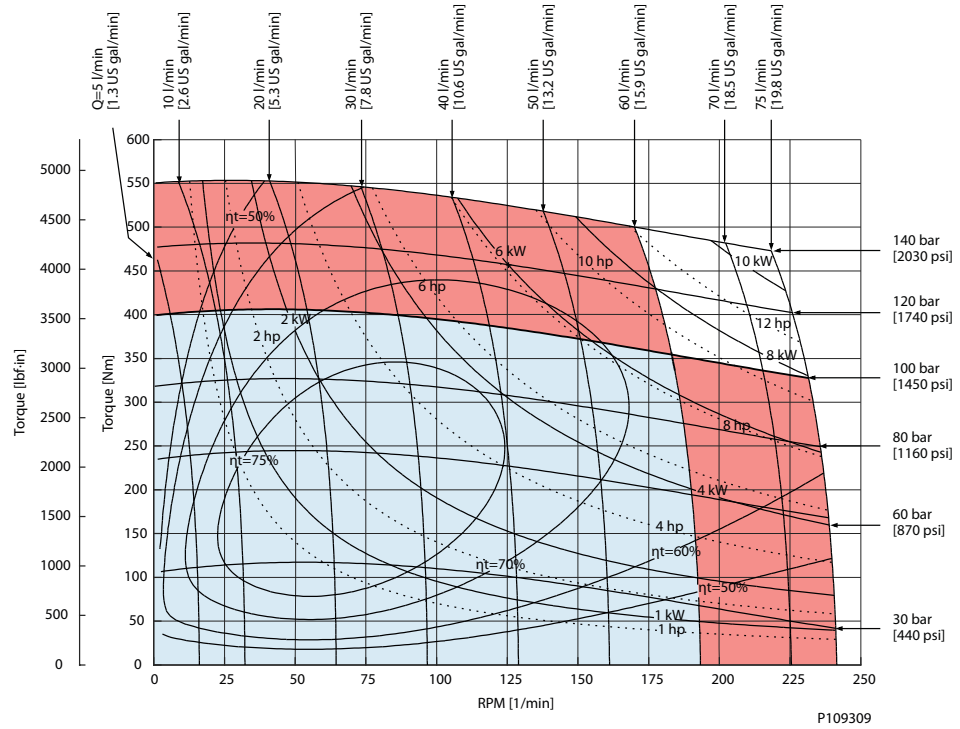
OMR X 315



OMR X 375

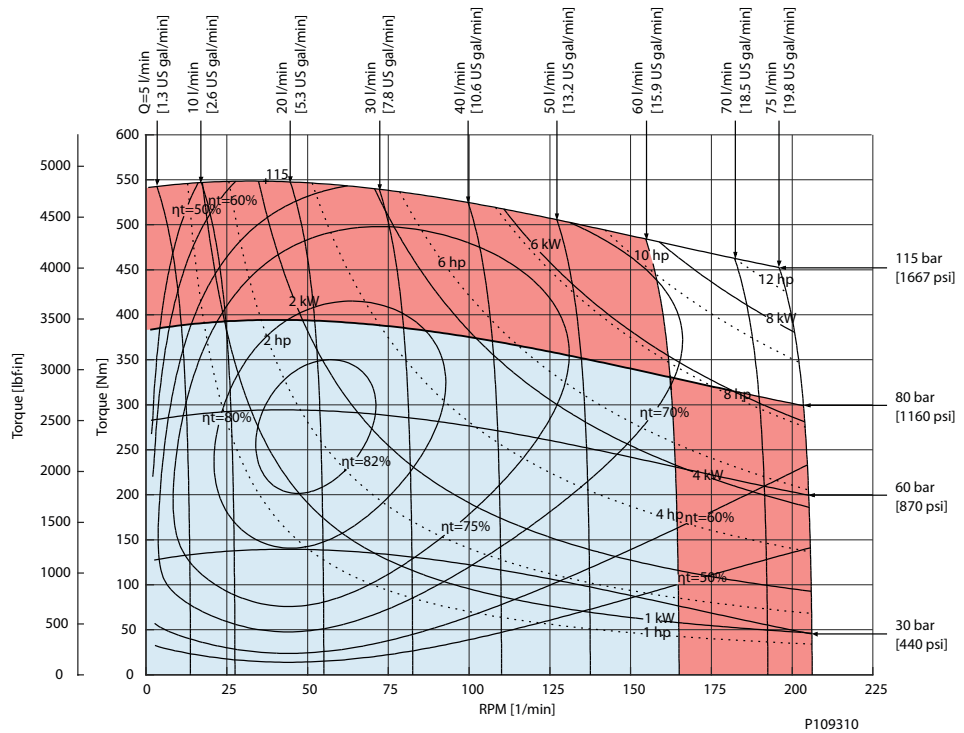

Technical Information

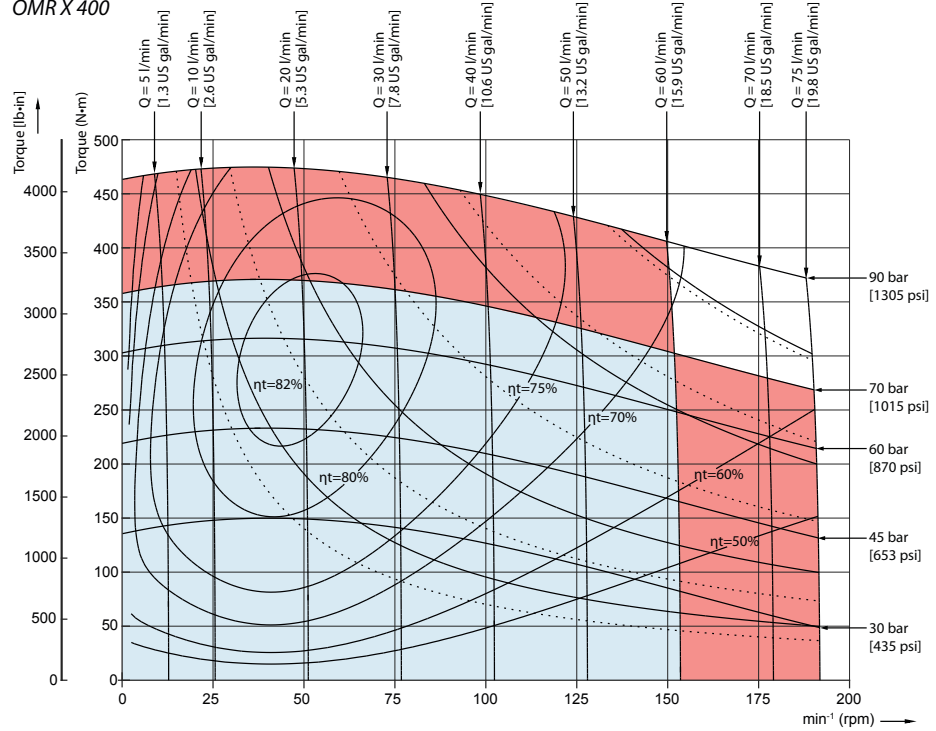
Orbital Motors Type OMP X and OMR X
OMR X function diagrams
OMR X 400
OMR X 400

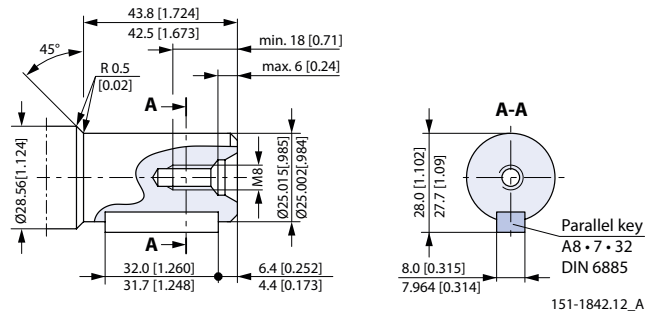
Technical Information
Orbital Motors Type OMP X and OMR X
OMR X Shaft version
OMP X and OMR X shaft versions
Cylindrical shaft 25 mm; Parallel key DIN 6885

Max. cont. torque: 340 N·m [3010 lb·in]; Max. int. torque 450 N·m [3980 lb·in]

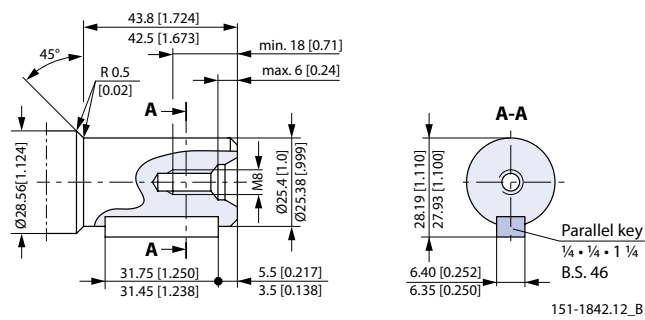
Cylindrical shaft 1 in; Parallel key B.S. 46

Max. cont. torque: 340 N·m [3010 lb·in]; Max. int. torque 450 N·m [3980 lb·in]

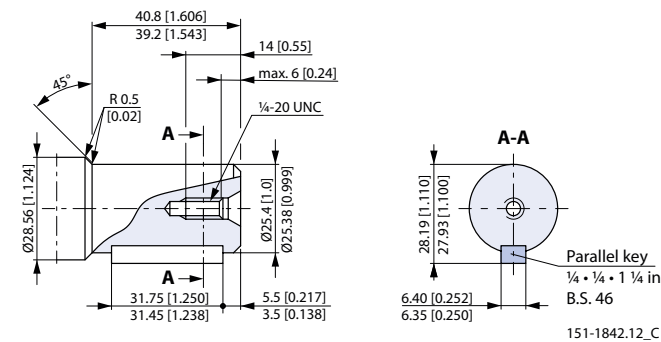
Cylindrical shaft 1 in; Parallel key B.S. 46 (US version)

Max. cont. torque: 340 N·m [3010 lb·in]; Max. int. torque 450 N·m [3980 lb·in]

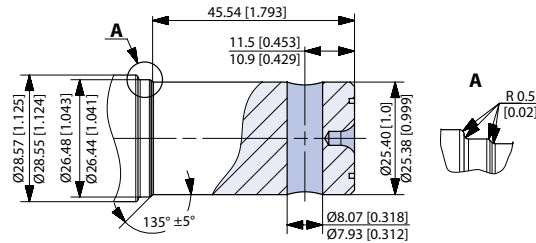
Technical Information
Orbital Motors Type OMP X and OMR X
OMR X Shaft version
Cylindrical shaft 1 in; Cross hole 8 mm

Max. torque: 200 N·m [1770 lb·in]

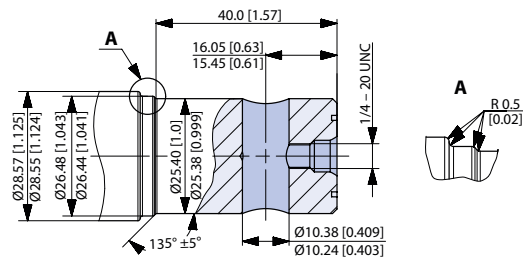
Cylindrical shaft 1 in; Cross hole 10.3 mm

Max. torque: 200 N·m [1770 lb·in]

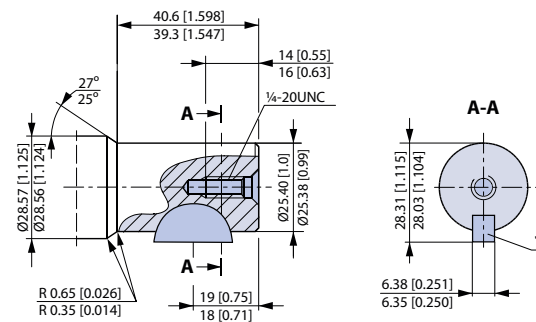
Cylindrical shaft 1 in (US version); SAE J502

1 Woodruff key ¼ x 1 in SAE J502

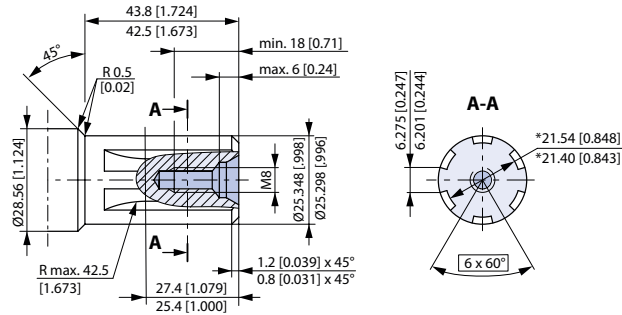
Technical Information
Orbital Motors Type OMP X and OMR X
OMR X Shaft version
Splined shaft B.S. 2059 (SAE 6B)

Straight-sided, bottom fitting, dep. Fit 2, Nom. size 1 in; * Deviates from B.S. 2059 (SAE 6B)

Max. cont. torque: 400 N·m [3540 lb·in]

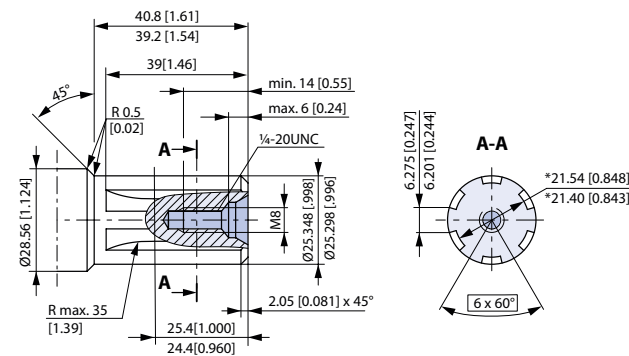
Splined shaft B.S. 2059 (SAE 6B); US version

Straight-sided, bottom fitting, deep. Fit 2; Nom. size 1 in, *Deviates from B.S. 2059 (SAE 6B)

Max. cont. torque 400 N·m [3540 lb·in]

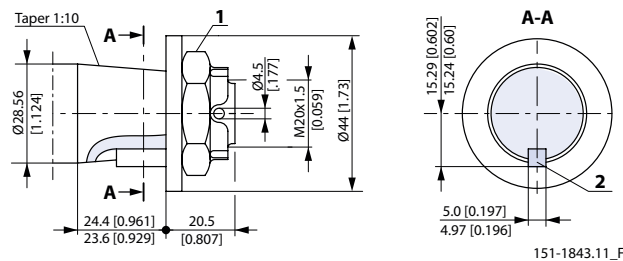
Tapered shaft (taper 1:10); Parallel key DIN 6885

1. DIN 937 NV 30; Tightening torque: 100 ± 10 N·m [885 ± 88.5 lb·in]

2. Parallel key B5 · 5 · 14; DIN 6885

Max. cont. torque: 400 N·m [3540 lb·in]

Technical Information
Orbital Motors Type OMP X and OMR X
OMR X port thread versions
Main port thread versions

Main ports overview

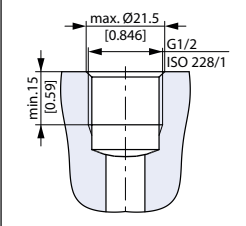
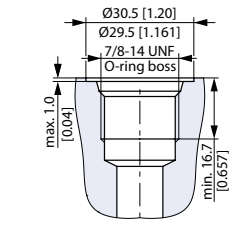
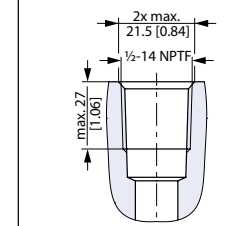
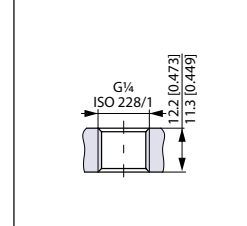
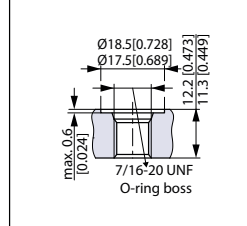
G ISO 228/1 – G1/2	UNF 7/8–14 UNF O-ring boss	NPTF 1/2–14 NPTF	G drain ISO 228/1 – G1/4	UNF drain 7/16–20 UNF O-ring boss
 <p>max. $\varnothing 21.5$ [0.846] G1/2 ISO 228/1 min. 1.5 [0.59]</p>	 <p>$\varnothing 30.5$ [1.20] $\varnothing 29.5$ [1.161] 7/8-14 UNF O-ring boss max. 1.0 [0.04] min. 16.7 [0.657]</p>	 <p>2x max. 21.5 [0.84] 1/2-14 NPTF max. 2.7 [1.06]</p>	 <p>G1/4 ISO 228/1 12.2 [0.473] 11.3 [0.449]</p>	 <p>$\varnothing 18.5$ [0.728] $\varnothing 17.5$ [0.689] 12.2 [0.473] 11.3 [0.449] 7/16-20 UNF O-ring boss max. 0.6 [0.024]</p>

OMR X manifold mount

For OMR X manifold mounting versions please see the dimension drawings for given OMR X motors listed below:

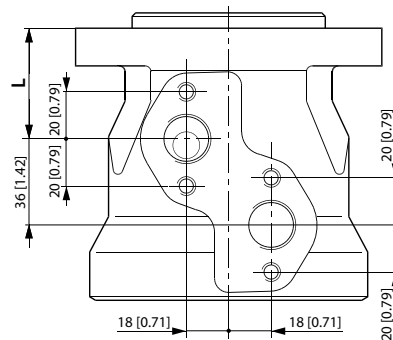

For L dimension please see the tables in the topics below:

- *EU version side port offset with 2-hole oval mounting flange (A2-flange)* on page 64
- *EU version end port version with 2-hole oval mounting flange (A2-flange)* on page 65
- *US version side port offset with 2-hole oval mounting flange (A2-flange)* on page 66
- *US version side port aligned with 2 hole oval mounting flange (A2)* on page 67
- *US version side port aligned with square mounting flange (C-flange)* on page 68

Technical Information

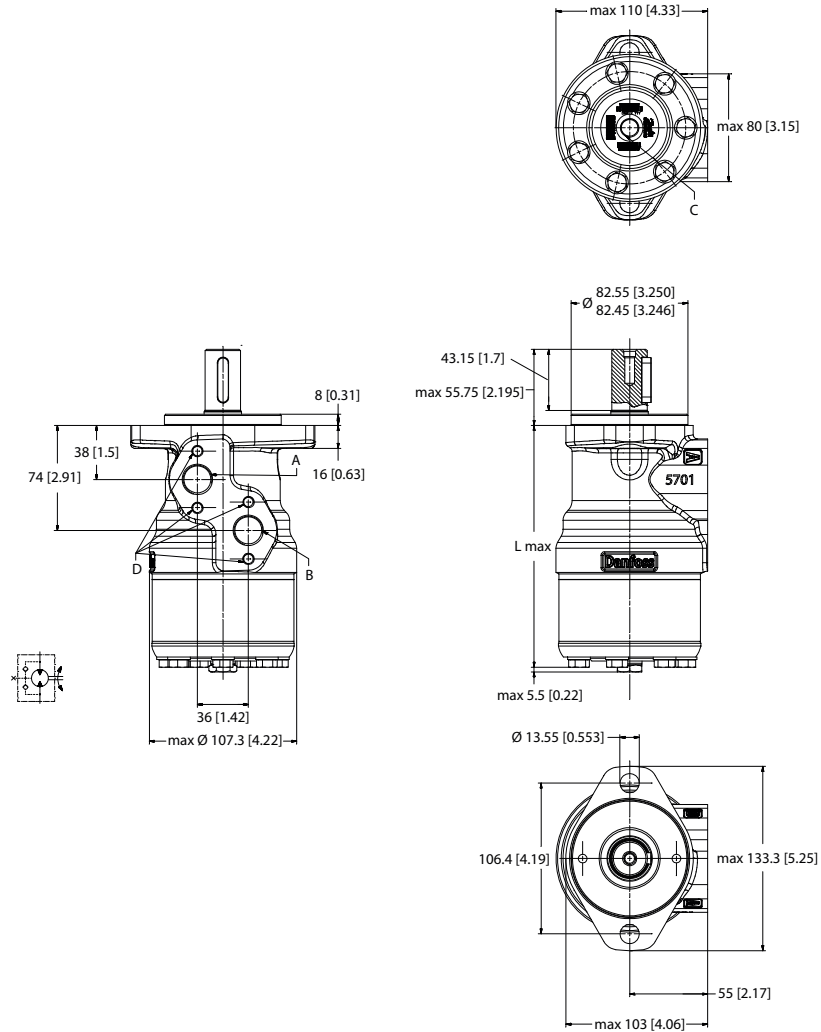
Orbital Motors Type OMP X and OMR X
OMR X dimensions
EU version side port offset with 2-hole oval mounting flange (A2-flange)

P109285

Port connections:
A, B Main ports: G 1/2; min 15 mm [0.59 in] deep

C Drain port: G 1/4; 12 mm [0.47 in] deep

Size	50	80	100	125	160	200	250	315	375	400
L max. mm [in]	137.8 [5.43]	142.8 [5.63]	142.8 [5.63]	146.2 [5.76]	150.6 [5.93]	156.6 [6.17]	163.6 [6.45]	172.3 [6.79]	179.8 [7.08]	183.6 [7.23]

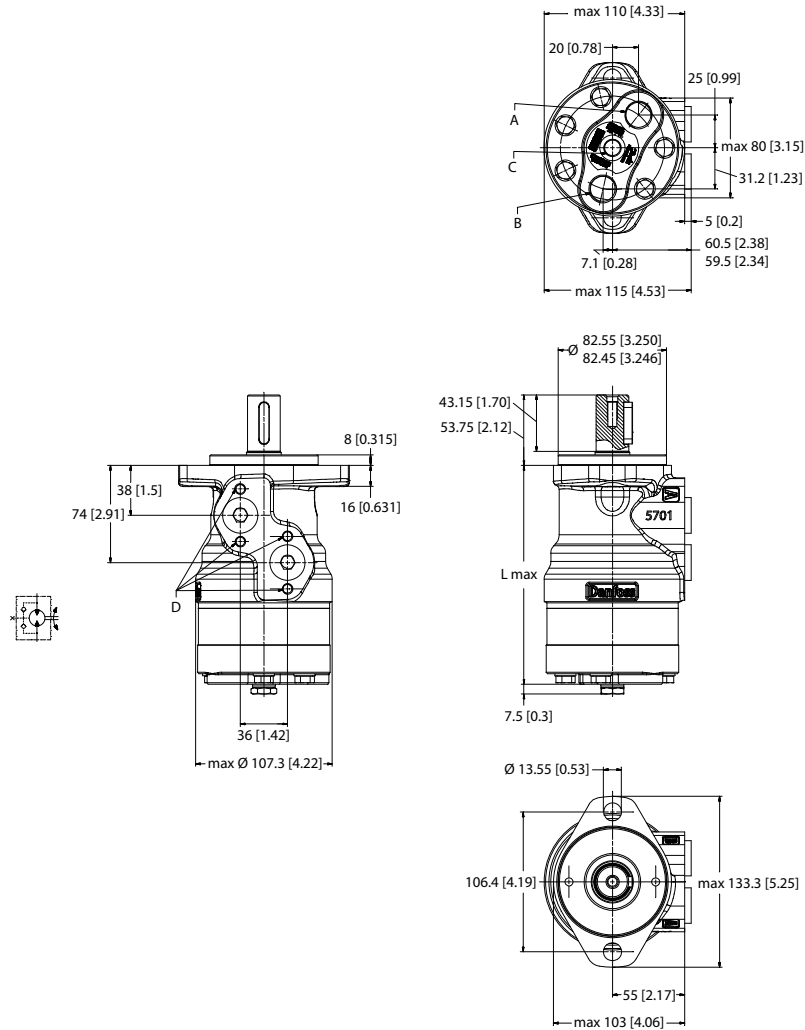
Technical Information
Orbital Motors Type OMP X and OMR X
OMR X dimensions
EU version end port version with 2-hole oval mounting flange (A2-flange)

P109287

Port connections:

- A, B** Main ports: G 1/2; min 15 mm [0.59 in] deep
C Drain port: G 1/4; 12 mm [0.47 in] deep
D Thread: M8; 13 mm [0.51 in] deep

Size	50	80	100	125	160	200	250	315	375
L max. mm [in]	150.3 [5.82]	155.3 [6.12]	155.3 [6.12]	158.7 [6.25]	163.1 [6.43]	169.1 [6.66]	176.1 [6.94]	184.6 [7.28]	192.3 [7.58]

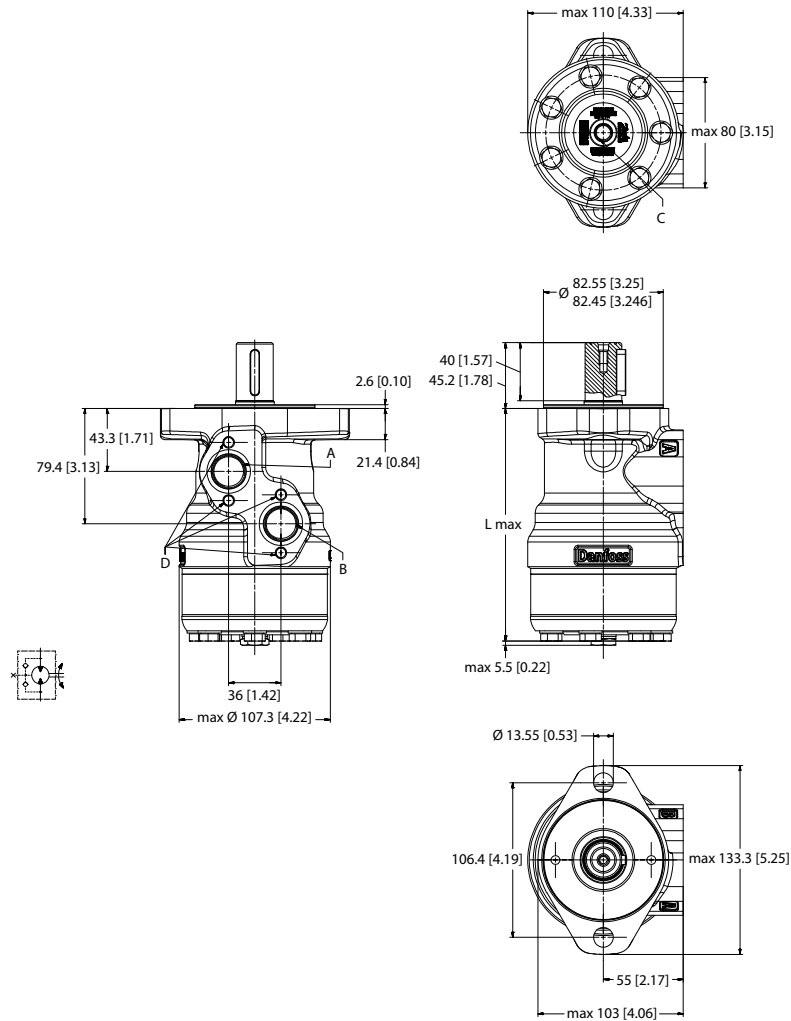
OMR X dimensions
US version side port offset with 2-hole oval mounting flange (A2-flange)

P109288

Port connections:

- A, B** Main ports: 7/8 - 14 UNF; min. 16.7 mm [0.66 in] deep
- C** Drain port: 7/16 - 20 UNF; 12 mm [0.47 in] deep
- D** Thread: M8; 13 mm [0.51 in] deep

Size	50	80	100	125	160	200	250	315	375
L max. mm [in]	143.2 [5.64]	148.2 [5.84]	148.2 [5.84]	151.6 [5.97]	156.0 [6.15]	162.0 [6.38]	169.0 [6.66]	177.7 [7.00]	185.2 [7.30]

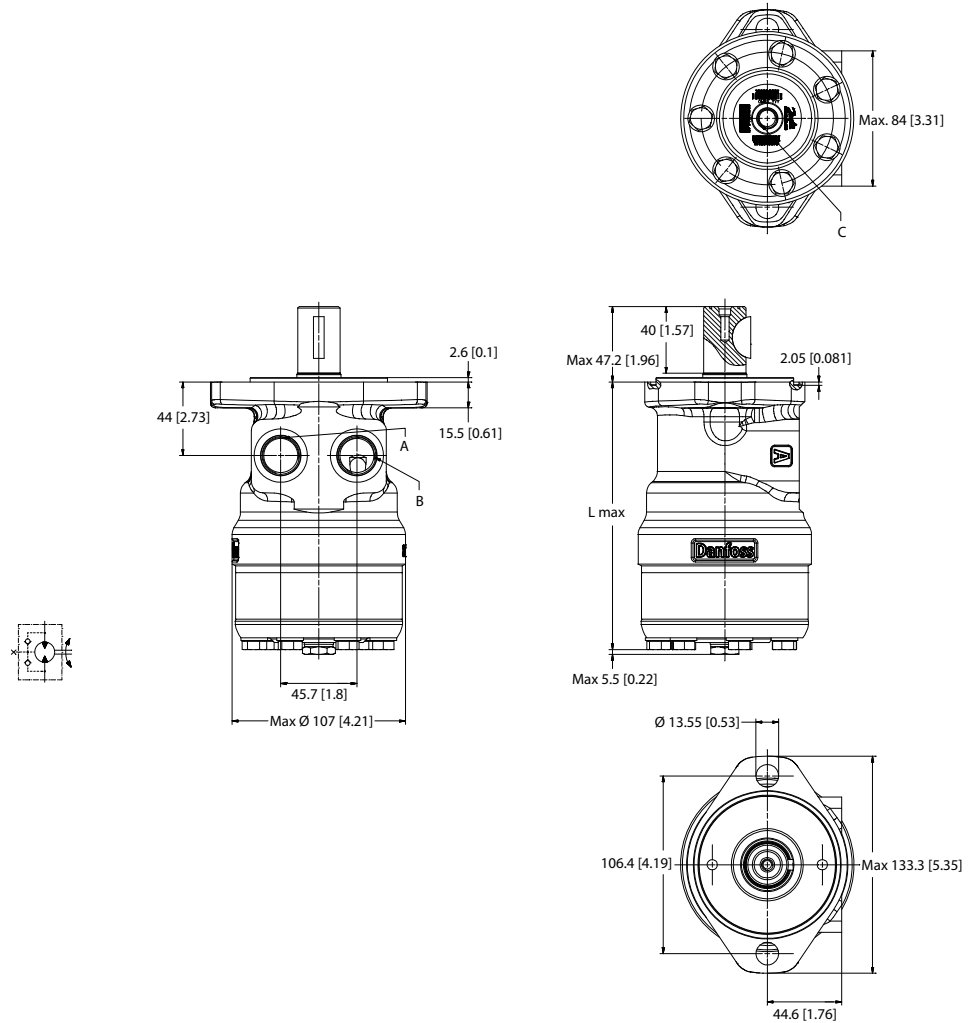
Technical Information
Orbital Motors Type OMP X and OMR X
OMR X dimensions
US version side port aligned with 2 hole oval mounting flange (A2)

P109445

Port connections:
A, B Main ports: 7/8 - 14 UNF; min. 16.7 mm [0.66 in] deep

C Drain port: 7/16 - 20 UNF; 12 mm [0.47 in] deep

Size	50	80	100	125	160	200	250	315	375	400
L max. mm [in]	137.8 [5.43]	142.8 [5.63]	142.8 [5.63]	146.2 [5.76]	150.6 [5.93]	156.6 [6.17]	163.6 [6.45]	172.3 [6.79]	179.8 [7.08]	183.6 [7.23]

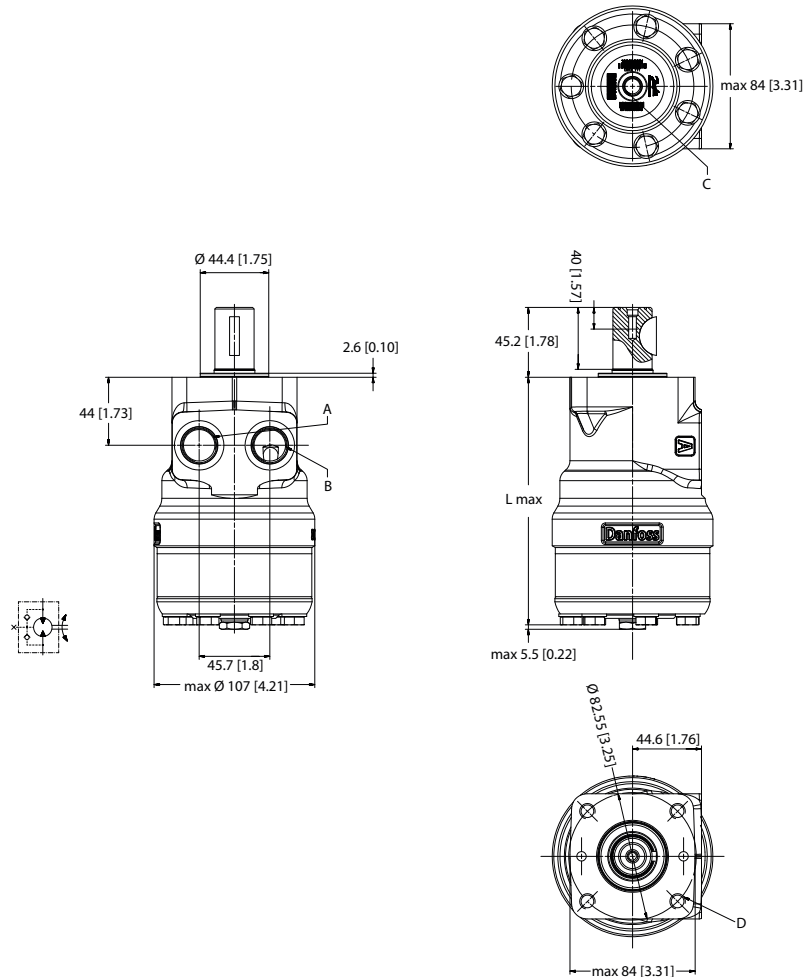
Technical Information
Orbital Motors Type OMP X and OMR X
OMR X dimensions
US version side port aligned with square mounting flange (C-flange)

P109289

Port connections:

- A, B** Main ports: 7/8 - 14 UNF; min. 16.7 mm [0.66 in] deep
- C** Drain port: 7/16 - 20 UNF; 12 mm [0.47 in] deep
- D** Thread: 3/8 - 16 UNC; 15 mm [0.59 in] deep

Size	80	100	125	160	200	250	315	375
L max. mm [in]	148.2 [5.84]	148.2 [5.84]	151.6 [5.97]	156.0 [6.15]	162.0 [6.38]	169.0 [6.66]	177.7 [7.0]	189.0 [7.45]

Technical Information

Orbital Motors Type OMP X and OMR X
Weight of motors
Weight of OMP X and OMR X motors

The large table of OMP X and OMR X motors weight according to ordering code number (see in bold font).

OMP X and OMR X weight

Code No.	kg	lb	Code No.	kg	lb	Code No.	kg	lb	Code No.	kg	lb
11185412	8,1	17,9	11185632	7,6	16,7	11185874	5,6	12,4	11186173	7,2	15,9
11185460	8,4	18,4	11185633	9,1	20,1	11185875	5,8	12,7	11186174	7,5	16,6
11185461	8,7	19,1	11185634	7,5	16,6	11185876	6,1	13,4	11186175	6,8	15,0
11185462	9,0	19,9	11185635	6,3	13,9	11185877	5,9	13,1	11186176	7,1	15,6
11185463	9,9	21,7	11185636	7,8	17,2	11185878	7,0	15,5	11186177	7,4	16,3
11185464	7,7	16,9	11185637	8,8	19,3	11185879	5,6	12,4	11186178	7,9	17,5
11185465	7,9	17,5	11185638	7,6	16,8	11185880	6,1	13,4	11186179	8,3	18,2
11185466	7,9	17,5	11185639	7,2	15,9	11185881	5,9	13,1	11186180	9,3	20,5
11185467	9,5	20,9	11185640	9,5	21,0	11185882	6,3	13,9	11186181	7,2	15,8
11185468	8,1	17,9	11185641	8,4	18,6	11185883	6,5	14,4	11186183	8,7	19,3
11185469	8,4	18,4	11185642	9,9	21,8	11185884	6,8	14,9	11186184	9,3	20,6
11185470	8,7	19,1	11185643	8,0	17,6	11185885	7,1	15,7	11186185	7,6	16,8
11185471	9,0	19,9	11185644	9,5	21,0	11185886	7,5	16,6	11186186	7,9	17,5
11185472	9,9	21,7	11185645	9,1	20,0	11185887	5,6	12,4	11186187	8,3	18,3
11185473	7,7	16,9	11185648	8,7	19,1	11185888	5,7	12,6	11186188	9,3	20,6
11185474	7,9	17,5	11185649	7,3	16,1	11185889	5,7	12,6	11186189	7,2	15,9
11185475	7,9	17,5	11185650	7,3	16,1	11185890	5,8	12,9	11186190	7,2	15,9
11185476	8,7	19,1	11185651	7,5	16,6	11185891	6,1	13,5	11186191	7,2	16,0
11185477	7,9	17,5	11185672	7,8	17,3	11185892	6,0	13,2	11186192	7,2	15,9
11185478	7,5	16,5	11185673	8,2	18,1	11185893	6,3	13,8	11186193	7,3	16,2
11185479	8,4	18,6	11185674	6,8	15,1	11185894	6,5	14,2	11186194	7,7	16,9
11185480	7,1	15,6	11185675	6,8	15,1	11185895	6,7	14,8	11186195	8,0	17,7
11185481	7,3	16,1	11185676	7,1	15,7	11185896	6,1	13,4	11186196	9,1	20,0
11185482	8,7	19,3	11185677	8,7	19,1	11185897	6,3	13,8	11186197	6,6	14,7
11185483	7,4	16,3	11185678	7,5	16,6	11185898	6,5	14,2	11186198	6,9	15,3
11185484	7,6	16,8	11185679	7,1	15,7	11185899	6,7	14,8	11186199	6,9	15,2
11185485	7,9	17,5	11185703	7,2	15,9	11185900	6,1	13,4	11186611	8,4	18,4
11185486	8,3	18,3	11185704	7,0	15,5	11185902	6,2	13,6	11186642	8,7	19,1
11185487	9,1	20,1	11185705	7,2	15,9	11185903	6,4	14,0	11186643	8,7	19,1
11185488	6,9	15,2	11185706	7,5	16,5	11185904	7,5	16,6	11186644	9,9	21,7
11185489	7,2	15,8	11185707	7,8	17,2	11185905	5,7	12,5	11186645	7,9	17,5
11185490	7,2	15,9	11185708	8,2	18,2	11185906	5,7	12,6	11186646	7,1	15,6
11185491	8,7	19,2	11185710	6,4	14,1	11185907	5,9	13,1	11186647	7,3	16,1
11185492	7,4	16,3	11185711	6,4	14,1	11185908	6,0	13,3	11186648	8,7	19,2
11185493	7,6	16,8	11185713	6,6	14,5	11185909	6,9	15,3	11186649	7,4	16,3
11185494	7,9	17,5	11185714	6,7	14,8	11185910	6,3	14,0	11186650	8,3	18,2
11185495	8,3	18,2	11185715	6,4	14,2	11185911	6,5	14,4	11186651	6,9	15,2
11185496	9,1	20,1	11185716	6,6	14,6	11185912	7,3	16,1	11186652	8,7	19,1
11185497	6,9	15,2	11185717	6,9	15,2	11185913	7,3	16,1	11186653	8,7	19,1
11185498	7,2	15,8	11185718	7,2	15,9	11185914	7,9	17,4	11186655	7,3	16,1
11185499	7,2	15,9	11185719	7,6	16,8	11186040	6,0	13,3	11186657	7,3	16,1

Weight of motors
OMP X and OMR X weight (continued)

Code No.	kg	lb	Code No.	kg	lb	Code No.	kg	lb	Code No.	kg	lb
11185500	7,9	17,5	11185720	5,7	12,6	11186041	5,3	11,7	11186658	7,5	16,6
11185501	8,7	19,3	11185721	5,8	12,8	11186042	6,6	14,6	11186659	7,5	16,6
11185502	7,4	16,3	11185722	5,8	12,8	11186043	5,7	12,5	11186660	7,5	16,6
11185503	7,6	16,8	11185723	5,8	12,8	11186044	5,8	12,9	11186662	7,5	16,6
11185504	7,9	17,5	11185724	6,0	13,2	11186046	6,0	13,3	11186664	7,5	16,6
11185505	8,3	18,3	11185725	6,3	13,8	11186047	6,3	13,9	11186665	7,8	17,3
11185506	9,1	20,1	11185726	6,1	13,5	11186049	6,6	14,6	11186667	8,2	18,1
11185507	6,9	15,3	11185727	5,8	12,8	11186050	6,6	14,6	11186670	6,8	15,1
11185508	7,2	15,9	11185728	6,4	14,2	11186052	7,0	15,5	11186671	7,1	15,7
11185509	7,2	15,9	11185729	6,9	15,1	11186054	5,2	11,5	11186673	7,1	15,7
11185510	6,8	15,1	11185730	5,7	12,6	11186056	5,2	11,6	11186674	7,1	15,7
11185511	7,1	15,7	11185731	5,8	12,8	11186057	5,4	12,0	11186675	7,1	15,7
11185512	7,1	15,7	11185732	6,3	13,8	11186059	5,5	12,2	11186677	7,5	16,6
11185513	8,7	19,1	11185733	6,4	14,2	11186060	5,2	11,5	11186680	7,1	15,7
11185514	8,7	19,1	11185734	6,6	14,6	11186061	5,4	11,9	11186681	7,1	15,7
11185515	7,5	16,6	11185735	7,2	15,9	11186062	5,5	12,2	11186682	7,5	16,6
11185516	8,7	19,1	11185736	6,9	15,2	11186063	5,5	12,2	11186684	6,8	15,1
11185517	7,3	16,1	11185737	5,8	12,8	11186064	6,1	13,5	11186685	7,8	17,3
11185518	7,3	16,1	11185738	6,0	13,2	11186065	6,3	13,9	11186686	7,5	16,6
11185519	7,3	16,1	11185739	6,1	13,5	11186066	6,5	14,4	11186687	7,0	15,5
11185520	7,5	16,6	11185740	5,7	12,5	11186067	6,9	15,2	11186688	7,5	16,5
11185521	7,1	15,7	11185742	5,8	12,7	11186068	7,3	16,1	11186691	5,7	12,5
11185522	7,5	16,6	11185743	6,2	13,6	11186069	5,5	12,1	11186692	5,8	12,9
11185523	7,5	16,6	11185745	6,2	13,6	11186071	5,5	12,1	11186693	5,4	12,0
11185524	7,5	16,6	11185746	6,2	13,6	11186072	5,7	12,5	11186694	6,1	13,5
11185525	7,8	17,3	11185748	6,3	14,0	11186073	5,8	12,8	11186695	5,7	12,6
11185526	6,8	15,0	11185749	6,4	14,0	11186074	5,6	12,3	11186696	5,8	12,8
11185527	7,9	17,3	11185750	6,3	14,0	11186075	5,9	13,1	11186697	6,4	14,2
11185528	8,2	18,1	11185751	6,5	14,4	11186076	6,1	13,5	11186698	6,6	14,6
11185530	8,2	18,1	11185752	6,6	14,4	11186077	6,3	13,9	11186699	5,8	12,7
11185531	9,0	19,9	11185753	6,6	14,4	11186079	6,6	14,5	11186702	6,2	13,6
11185533	9,0	19,9	11185755	6,5	14,4	11186081	6,9	15,2	11186705	6,3	14,0
11185534	9,0	19,9	11185756	6,6	14,4	11186083	7,3	16,1	11186706	6,3	14,0
11185535	9,2	20,4	11185757	6,5	14,4	11186085	5,5	12,2	11186707	6,3	14,0
11185536	6,8	15,1	11185758	6,8	15,0	11186086	5,5	12,2	11186708	6,5	14,4
11185537	6,8	15,1	11185760	6,8	15,0	11186088	5,7	12,6	11186710	6,8	15,0
11185538	6,8	15,1	11185761	7,1	15,7	11186090	5,8	12,8	11186711	6,8	15,0
11185539	7,1	15,7	11185764	7,1	15,7	11186091	5,5	12,1	11186712	7,1	15,7
11185541	7,1	15,7	11185765	6,8	15,0	11186092	5,7	12,6	11186713	7,1	15,7
11185542	7,1	15,7	11185767	7,6	16,7	11186093	5,8	12,8	11186714	7,6	16,7
11185544	7,1	15,7	11185769	5,7	12,5	11186094	5,4	12,0	11186715	5,7	12,5
11185545	8,7	19,1	11185770	6,0	13,3	11186095	6,2	13,6	11186717	5,7	12,6
11185547	8,7	19,1	11185771	5,7	12,6	11186096	6,6	14,6	11186718	5,7	12,6
11185548	7,3	16,1	11185773	5,7	12,6	11186097	6,9	15,3	11186719	5,7	12,6
11185549	7,5	16,6	11185775	5,7	12,6	11186098	7,4	16,2	11186720	5,7	12,6

Technical Information
 Orbital Motors Type OMP X and OMR X

Weight of motors

OMP X and OMR X weight (continued)

Code No.	kg	lb	Code No.	kg	lb	Code No.	kg	lb	Code No.	kg	lb
11185551	7,9	17,3	11185776	5,7	12,6	11186099	5,6	12,3	11186721	5,9	13,0
11185553	7,9	17,3	11185779	5,7	12,6	11186100	5,6	12,3	11186722	5,9	13,0
11185554	8,2	18,1	11185780	5,7	12,6	11186101	5,7	12,7	11186723	5,9	13,0
11185556	9,0	19,9	11185781	5,7	12,6	11186103	6,0	13,2	11186725	6,0	13,3
11185558	6,8	15,1	11185784	5,9	13,0	11186104	6,4	14,0	11186726	6,4	14,0
11185560	7,1	15,7	11185786	6,0	13,3	11186105	5,7	12,7	11186727	6,6	14,5
11185562	7,1	15,7	11185787	6,0	13,3	11186106	5,9	12,9	11186728	7,1	15,7
11185564	8,7	19,1	11185788	6,0	13,3	11186107	5,6	12,3	11186729	5,7	12,6
11185566	8,7	19,1	11185789	6,0	13,3	11186108	5,8	12,7	11186730	6,0	13,3
11185567	7,3	16,1	11185790	6,0	13,3	11186109	5,9	12,9	11186731	6,2	13,6
11185569	7,3	16,1	11185792	6,2	13,6	11186110	6,1	13,6	11186732	6,3	14,0
11185570	7,5	16,6	11185794	6,4	14,0	11186111	6,3	14,0	11186734	6,8	15,0
11185572	7,5	16,6	11185796	6,6	14,4	11186112	6,6	14,5	11186735	7,1	15,7
11185573	7,8	17,3	11185798	6,8	15,0	11186113	6,9	15,3	11186736	7,1	15,7
11185575	7,8	17,3	11185800	7,1	15,7	11186115	5,5	12,2	11186737	7,6	16,7
11185576	8,2	18,1	11185802	7,6	16,7	11186116	5,5	12,2	11186738	5,7	12,6
11185578	8,2	18,1	11185805	5,7	12,6	11186117	5,7	12,6	11186739	5,9	13,0
11185579	8,2	18,1	11185806	5,7	12,6	11186118	5,8	12,8	11186740	6,0	13,3
11185580	9,0	19,9	11185808	5,9	13,0	11186119	5,5	12,1	11186742	5,7	12,6
11185581	9,0	19,9	11185810	6,0	13,3	11186120	6,4	14,0	11186743	5,7	12,6
11185582	6,8	15,1	11185811	6,9	15,3	11186121	7,1	15,7	11186744	5,9	12,9
11185583	6,8	15,1	11185814	6,2	13,6	11186122	5,3	11,7	11186745	6,1	13,4
11185584	6,8	15,1	11185815	6,2	13,6	11186123	5,5	12,1	11186746	6,3	13,8
11185585	7,1	15,7	11185817	6,3	14,0	11186124	5,5	12,0	11186747	6,5	14,2
11185587	7,1	15,7	11185819	6,5	14,4	11186125	5,7	12,6	11186748	6,5	14,4
11185588	7,1	15,7	11185820	6,5	14,4	11186126	5,9	12,9	11186749	6,5	14,4
11185590	7,1	15,7	11185821	6,5	14,4	11186127	6,1	13,4	11186750	6,1	13,5
11185592	8,6	19,1	11185824	6,8	15,0	11186128	6,3	13,9	11186751	6,3	13,8
11185593	8,6	19,1	11185825	7,9	17,4	11186129	6,6	14,6	11186816	5,2	11,5
11185594	7,3	16,1	11185827	7,1	15,7	11186130	7,1	15,6	11186817	6,2	13,8
11185595	7,5	16,6	11185828	7,6	16,7	11186131	5,3	11,6	11186818	7,3	16,2
11185596	7,8	17,3	11185829	5,7	12,5	11186132	5,3	11,6	11186819	7,1	15,7
11185598	8,2	18,1	11185831	5,7	12,6	11186133	5,4	12,0	11186820	6,8	15,0
11185599	9,0	19,9	11185832	5,7	12,6	11186134	5,6	12,2	11186842	7,5	16,6
11185600	6,8	15,0	11185833	5,7	12,6	11186135	5,3	11,6	11186843	6,5	14,2
11185601	7,1	15,6	11185835	5,9	13,0	11186136	5,4	12,0	11186844	6,7	14,8
11185602	7,1	15,7	11185837	6,0	13,3	11186137	5,3	11,6	11187718	6,3	13,8
11185603	8,7	19,2	11185844	6,5	14,4	11186138	5,5	12,0	11187798	7,3	16,2
11185604	7,4	16,3	11185846	7,1	15,7	11186142	6,1	13,5	11189074	6,0	13,3
11185605	7,6	16,7	11185847	5,7	12,5	11186143	7,6	16,8	11189749	5,2	11,5
11185606	7,9	17,4	11185848	5,7	12,6	11186144	8,0	17,6	11189752	5,3	11,6
11185607	8,3	18,2	11185849	5,7	12,6	11186145	9,0	19,9	11191475	6,8	15,1
11185608	9,1	20,1	11185850	5,7	12,6	11186146	6,6	14,6	11191997	6,9	15,2
11185609	6,9	15,2	11185851	6,0	13,3	11186147	6,9	15,2	11192079	5,2	11,5
11185610	7,2	15,8	11185852	5,7	12,6	11186148	6,9	15,2	11192444	6,0	13,3

Weight of motors
OMP X and OMR X weight (continued)

Code No.	kg	lb	Code No.	kg	lb	Code No.	kg	lb	Code No.	kg	lb
11185611	7,2	15,8	11185856	6,8	14,9	11186149	6,9	15,2	11192482	5,8	12,7
11185612	7,3	16,1	11185857	6,3	13,9	11186150	8,7	19,2	11192738	5,7	12,6
11185613	7,5	16,6	11185858	5,9	13,0	11186151	7,4	16,2	11192763	5,3	11,7
11185614	8,2	18,1	11185859	5,9	13,0	11186152	7,9	17,4	11192764	5,3	11,7
11185615	7,3	16,1	11185860	5,7	12,6	11186153	9,3	20,5	11192766	5,2	11,6
11185616	7,5	16,6	11185861	6,0	13,2	11186154	7,2	15,8	11192811	5,9	13,1
11185617	7,5	16,6	11185862	6,1	13,5	11186155	7,2	15,8	11192942	6,9	15,2
11185618	7,8	17,3	11185863	6,8	15,1	11186156	8,7	19,2	11192943	7,6	16,7
11185620	8,2	18,1	11185864	6,1	13,5	11186157	7,4	16,3	11192967	5,8	12,8
11185621	6,8	15,1	11185865	6,4	14,2	11186158	7,6	16,8	11192987	6,0	13,2
11185622	7,1	15,7	11185866	6,3	13,8	11186159	7,9	17,5	11193171	6,5	14,4
11185624	7,1	15,7	11185867	6,5	14,3	11186160	8,3	18,2	11193431	8,5	18,7
11185626	7,1	15,7	11185868	6,3	13,8	11186161	9,3	20,5	11193624	7,8	17,3
11185627	7,3	16,1	11185869	6,5	14,2	11186162	6,9	15,2	11193633	8,2	18,1
11185628	7,8	17,3	11185870	6,7	14,8	11186163	7,2	15,8	11193635	6,3	13,9
11185629	7,1	15,7	11185871	7,0	15,5	11186164	7,2	15,9	11193640	5,9	13,1
11185630	7,1	15,7	11185872	7,5	16,4	11186171	6,9	15,2	11194011	7,1	15,7
11185631	7,5	16,6	11185873	5,6	12,4	11186172	7,2	15,8	11194028	6,4	14,0



Hydraulik · Automation



Technical Information

Orbital Motors Type OMP X and OMR X



Hydraulik · Automation

Danfoss

Technical Information

Orbital Motors Type OMP X and OMR X



Hydraulik · Automation



Technical Information

Orbital Motors Type OMP X and OMR X

Products we offer:

- Bent Axis Motors
- Closed Circuit Axial Piston Pumps and Motors
- Displays
- Electrohydraulic Power Steering
- Electrohydraulics
- Hydraulic Power Steering
- Integrated Systems
- Joysticks and Control Handles
- Microcontrollers and Software
- Open Circuit Axial Piston Pumps
- Orbital Motors
- PLUS+1® GUIDE
- Proportional Valves
- Sensors
- Steering
- Transit Mixer Drives

Danfoss Power Solutions is a global manufacturer and supplier of high-quality hydraulic and electronic components. We specialize in providing state-of-the-art technology and solutions that excel in the harsh operating conditions of the mobile off-highway market. Building on our extensive applications expertise, we work closely with our customers to ensure exceptional performance for a broad range of off-highway vehicles.

We help OEMs around the world speed up system development, reduce costs and bring vehicles to market faster.

Danfoss – Your Strongest Partner in Mobile Hydraulics.

Go to www.powersolutions.danfoss.com for further product information.

Wherever off-highway vehicles are at work, so is Danfoss. We offer expert worldwide support for our customers, ensuring the best possible solutions for outstanding performance. And with an extensive network of Global Service Partners, we also provide comprehensive global service for all of our components.

Please contact the Danfoss Power Solution representative nearest you.

Comatrol

www.comatrol.com

Turolla

www.turollaocg.com

Hydro-Gear

www.hydro-gear.com

Daikin-Sauer-Danfoss

www.daikin-sauer-danfoss.com

Local address:

Danfoss Power Solutions (US) Company
2800 East 13th Street
Ames, IA 50010, USA
Phone: +1 515 239 6000

Danfoss Power Solutions GmbH & Co. OHG
Krokamp 35
D-24539 Neumünster, Germany
Phone: +49 4321 871 0

Danfoss Power Solutions ApS
Nordborgvej 81
DK-6430 Nordborg, Denmark
Phone: +45 7488 2222

Danfoss Power Solutions Trading (Shanghai) Co., Ltd.
Building #22, No. 1000 Jin Hai Rd
Jin Qiao, Pudong New District
Shanghai, China 201206
Phone: +86 21 3418 5200

Danfoss can accept no responsibility for possible errors in catalogues, brochures and other printed material. Danfoss reserves the right to alter its products without notice. This also applies to products already on order provided that such alterations can be made without changes being necessary in specifications already agreed. All trademarks in this material are property of the respective companies. Danfoss and the Danfoss logotype are trademarks of Danfoss A/S. All rights reserved.