

Characteristics

The direct operated control valve D3FP of the nominal size NG10 (CETOP 05) shows extremely high dynamics combined with high flow. It is the preferred choice for highest accuracy in positioning of hydraulic axis and controlling of pressure and velocity.

Driven by the patented VCD® actuator the D3FP reaches the frequency response of real servovalves.

At power-down the spool moves in a defined position. All common input signals are available.

Features

- Real servovalve dynamics
 (-3 dB / 350 Hz at ± 5 % input signal)
- Max. tank pressure 250 bar
 (with external drain port Y)
- Defined spool positioning at power-down - optional
 P-A/B-T or P-B/A-T or center position
 (for overlapped spools)
- Onboard electronics
- Spool / sleeve design

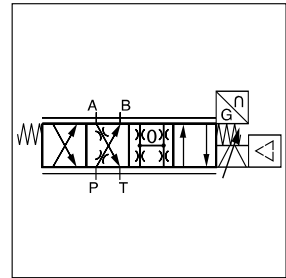
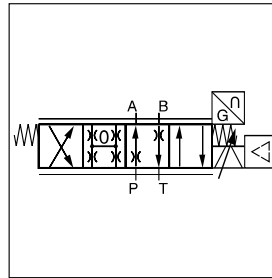
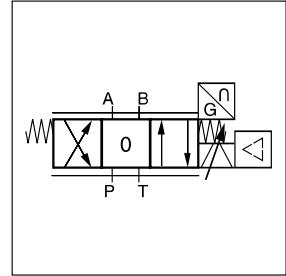
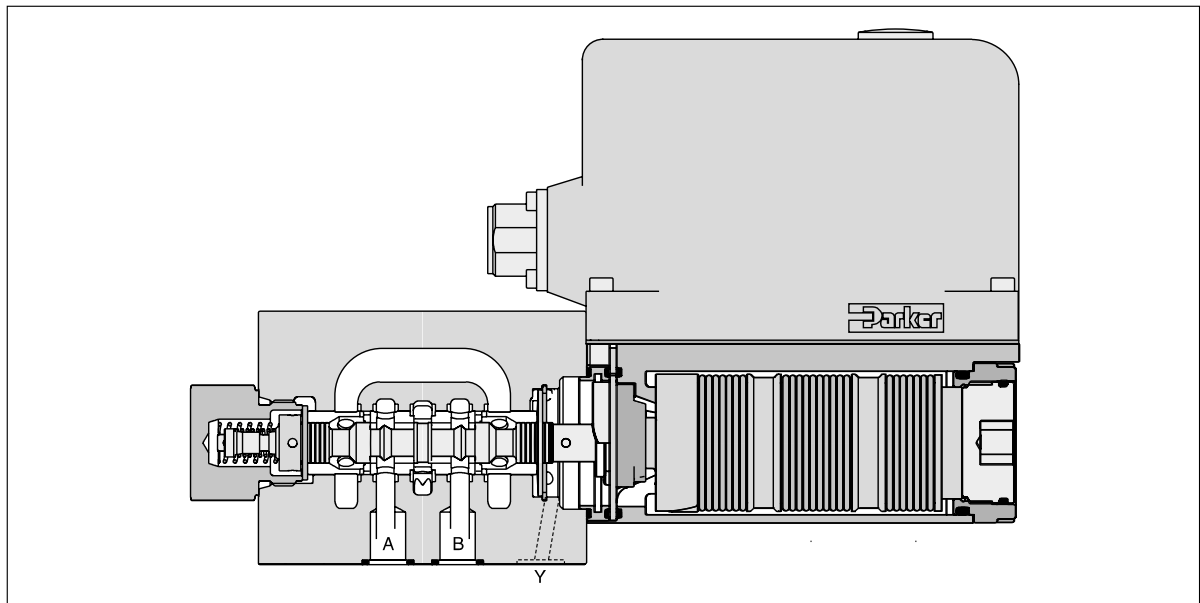
3

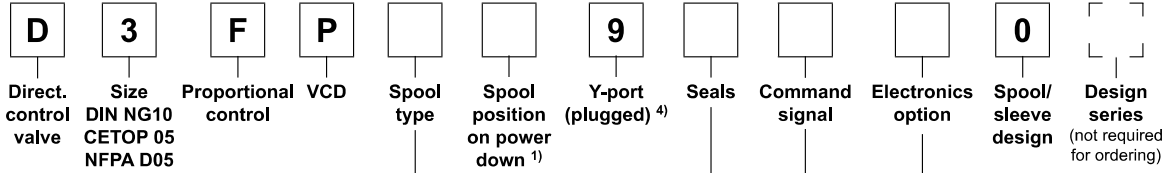
Catalogue MSG11-3500/UK
Ordering Code
**Direct Operated Proportional DC Valve
 Series D3FP**

3

Code	Spool type	Flow [l/min] at Δp 35 bar per metering edge
Zerolap		
E50P		50
E50Y		100
B60P	$Q_B = Q_A/2$ 	50
B60Y	$Q_B = Q_A/2$ 	100
Underlap approx. -0.5 %		
E55P		50
E55Y		100
Overlap		
E01P		50
E01Y		100
E02P		50
E02Y		100
B31P	$Q_B = Q_A/2$ 	50 / 25
B31Y		100 / 50
B32P	$Q_B = Q_A/2$ 	50 / 25
B32Y		100 / 50

Code	Connection type
0	6 + PE acc. EN175201-804
5	11 + PE acc. EN175201-804
7	6 + PE + Enable

Code	Signal	Function
B	+/- 10 V	0...+10 V -> P-A
E	+/- 20 mA	0...+20 mA -> P-A
S	4...20 mA	12...20 mA -> P-A

Code	Seals
N	NBR
V	FPM
H	for HFC fluid

Code	Spool pos. at power down
A ²⁾	
B ²⁾	
C ³⁾	

Short delivery time for all variations

For regenerative and hybrid function please refer solutions with sandwich- and adaptor plates "A10-1664 / A10-1665L / H10-1662 / H10-1666L" in chapter 12.

Please order connector separately, see chapter 3 accessories.

Parametrizing cable OBE -> RS232, item no. 40982923

¹⁾ On power down the spool moves in a defined position. This cannot be guaranteed in case of single flow path on the control edge A – T resp. B – T with pressure drops above 120 bar or contamination in the hydraulic fluid.

²⁾ Approx. 10 % opening, only zerolapped spools and underlapped spools.

³⁾ Only for overlapped spools.

⁴⁾ Plug in the Y-port needs to be removed at tank pressure >35 bar.

D3FP UK.indd 27.07.22



General			
Design	Direct operated servo proportional DC valve		
Actuation	VCD® actuator		
Size	NG10 / CETOP 05 / NFPA D05		
Mounting interface	DIN 24340 / ISO 4401 / CETOP RP121 / NFPA		
Mounting position	unrestricted		
Ambient temperature	[°C]	-20...+50	
MTTF _D value ¹⁾	[years]	150	
Weight	[kg]	6.5	
Vibration resistance	[g]	10 Sinus 5...2000 Hz acc. IEC 68-2-6 10 (RMS) Random noise 20...2000 Hz acc. IEC 68-2-36 15 Shock acc. IEC 68-2-27	
Hydraulic			
Max. operating pressure	[bar]	Ports P, A, B 350, port T 35 for internal drain, 250 for external drain, port Y 35 ²⁾	
Fluid	Hydraulic oil according to DIN 51524 ... 535, other on request		
Fluid temperature	[°C]	-20...+60 (NBR: -25...+60)	
Viscosity	permitted	[cSt]/[mm ² /s]	20...400
	recommended	[cSt]/[mm ² /s]	30...80
Filtration	ISO 4406; 18/16/13		
Flow nominal	at Δp=35 bar per control edge ³⁾		
	[l/min]	50 / 100	
Flow maximum	[l/min]	150	
Leakage at 100 bar	[ml/min]	<400 (zerolap spool); <100 (overlap spool)	
Opening point	[%]	set to 19 command signal (see flow characteristics)	
Static / Dynamic			
Step response at 100 % step ⁴⁾	[ms]	<6	
Frequency response (±5 % signal) ⁴⁾	[Hz]	200 (amplitude ratio -3 dB), 200 (phase lag -90°)	
Hysteresis	[%]	<0.05	
Sensitivity	[%]	<0.03	
Temperature drift	[%/K]	<0.025	
Electrical characteristics			
Duty ratio	[%]	100	
Protection class	IP65 in accordance with EN 60529 (with correctly mounted plug-in connector)		
Supply voltage/ripple	[V]	22 ... 30, electric shut-off at < 19, ripple <5 % eff., surge free	
Current consumption max.	[A]	3.5	
Pre-fusing	[A]	4.0 medium lag	
Input signal			
Code B	Voltage	[V]	10...0...-10, ripple <0.01 % eff., surge free, 0...+10 V P->A
	Impedance	[kOhm]	100
Code E	Current	[mA]	20...0...-20, ripple <0.01 % eff., surge free, 0...+20 mA P->A
	Impedance	[Ohm]	<250
Code S	Current	[mA]	4...12...20, ripple <0.01 % eff., surge free, 12...20 mA P->A <3.6 mA = disable, >3.8 mA = according to NAMUR NE43
	Impedance	[Ohm]	<250
Differential input max.			
Code 0	[V]	30 for terminal D and E against PE (terminal G)	
Code 5	[V]	30 for terminal 4 and 5 against PE (terminal ⊥)	
Code 7	[V]	30 for terminal D and E against PE (terminal G)	
Enable signal (only code 5/7)	[V]	5...30, Ri = > 8 kOhm	
Diagnostic signal	[V]	+10...0...-10 / +12.5 error detection, rated max. 5 mA	
EMC	EN 61000-6-2, EN 61000-6-4		
Electrical connection	Code 0/7	6 + PE acc. EN 175201-804	
	Code 5	11 + PE acc. EN 175201-804	
Wiring min.	Code 0/7	[mm ²]	7 x 1.0 (AWG 16) overall braid shield
	Code 5	[mm ²]	8 x 1.0 (AWG 16) overall braid shield
Wiring length max.	[m]	50	

¹⁾ If valves with onboard electronics are used in safety-related parts of control systems, in case the safety function is requested, the valve electronics voltage supply is to be switched off by a suitable switching element with sufficient reliability.

²⁾ For applications with p_r>35 bar (max. 250 bar) the Y-port has to be connected and the plug in the Y-port has to be removed.

³⁾ Flow rate for different Δp per control edge: $Q_x = Q_{Nom.} \cdot \sqrt{\frac{\Delta p_x}{\Delta p_{Nom.}}}$

⁴⁾ Measured with load (100 bar pressure drop/two control edges).

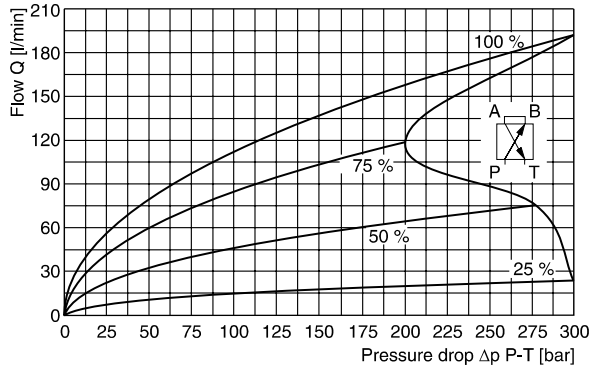
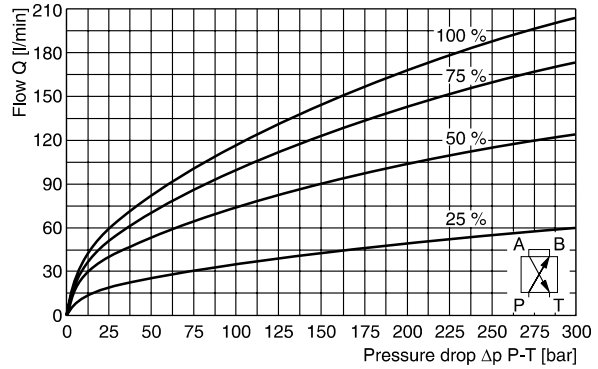
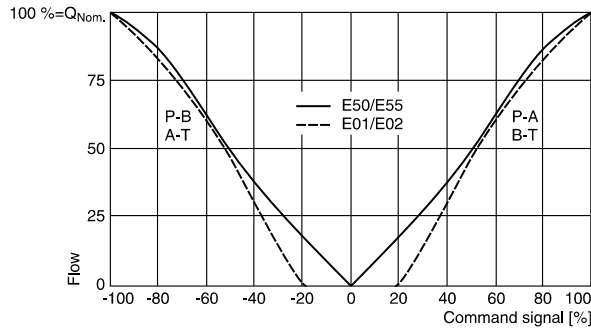
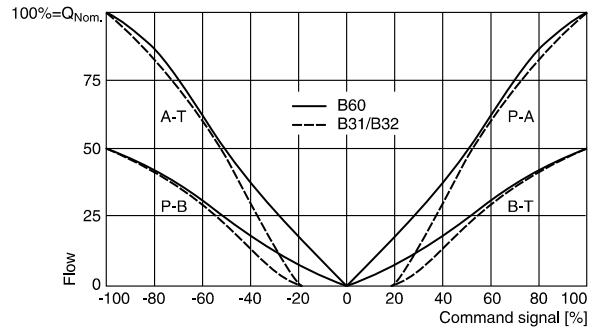
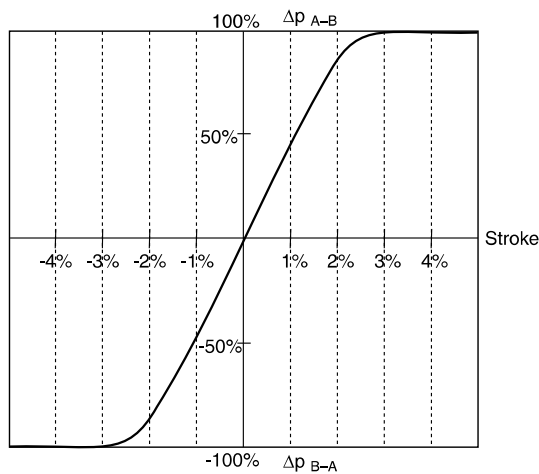
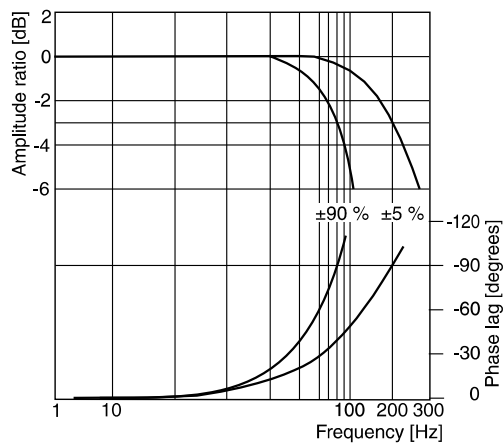
Catalogue MSG11-3500/UK
Characteristic Curves
**Direct Operated Proportional DC Valve
 Series D3FP**
3
Functional limits ¹⁾
 at 25 %, 50 %, 75 % and 100 % command signal
 Spool type **E01Y/E02Y**

Functional limits ¹⁾
 at 25 %, 50 %, 75 % and 100 % command signal
 Spool type **E50Y/E55Y**

Flow curves
 (Overlapped spool set to opening point 19 %)
 at $\Delta p = 35$ bar per metering edge
 Spool type **E50/E55, E01/E02**

 Spool type **B31/B32, B60**

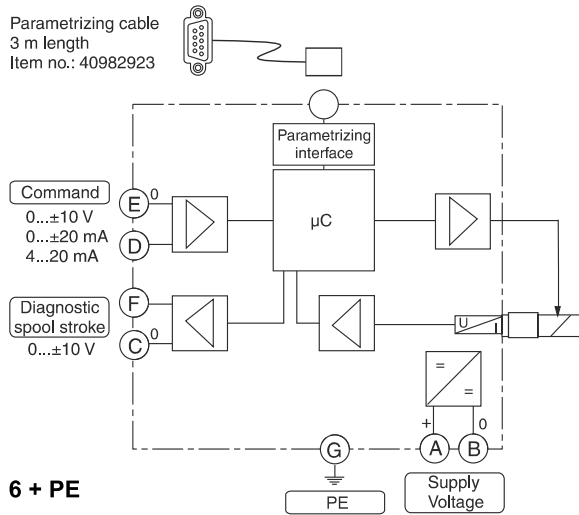
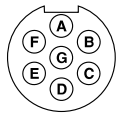
Pressure gain

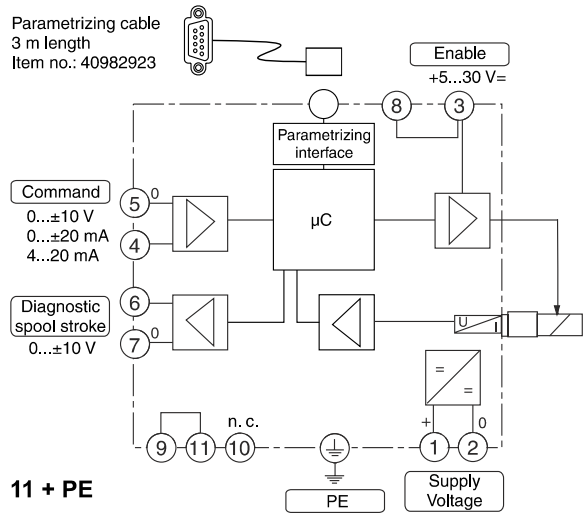
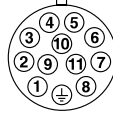
Frequency response
 ± 5 % command signal
 ± 90 % command signal

¹⁾ When exceeding the functional limits, for a period of time the valve will go into fail safe and power supply needs to be switched off/on to re-enable the valve.

D3FP UK.indd 27.07.22



Catalogue MSG11-3500/UK
Block Diagrams
**Direct Operated Proportional DC Valve
 Series D3FP**
Code 0

 Parametrizing cable
 3 m length
 Item no.: 40982923

6 + PE

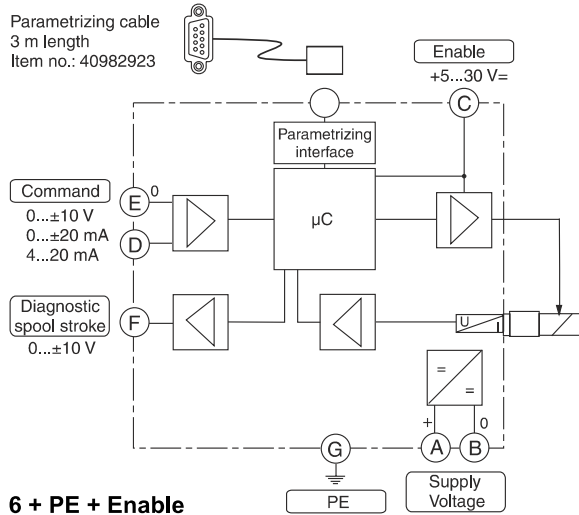
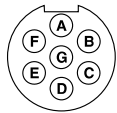
Code 5

 Parametrizing cable
 3 m length
 Item no.: 40982923

11 + PE

3
Code 7

 Parametrizing cable
 3 m length
 Item no.: 40982923

6 + PE + Enable

1) Do not connect with supply voltage zero.

ProPxD interface program

The ProPxD software allows quick and easy setting of the digital valve electronics. Individual parameters as well as complete settings can be viewed, changed and saved via the comfortable user interface. Parameter sets saved in the non-volatile memory can be loaded to other valves of the same type or printed out for documentation purposes.

3

The PC software can be downloaded free of charge at www.parker.com/isde – see page “Support” or directly at www.parker.com/propxd.

Features



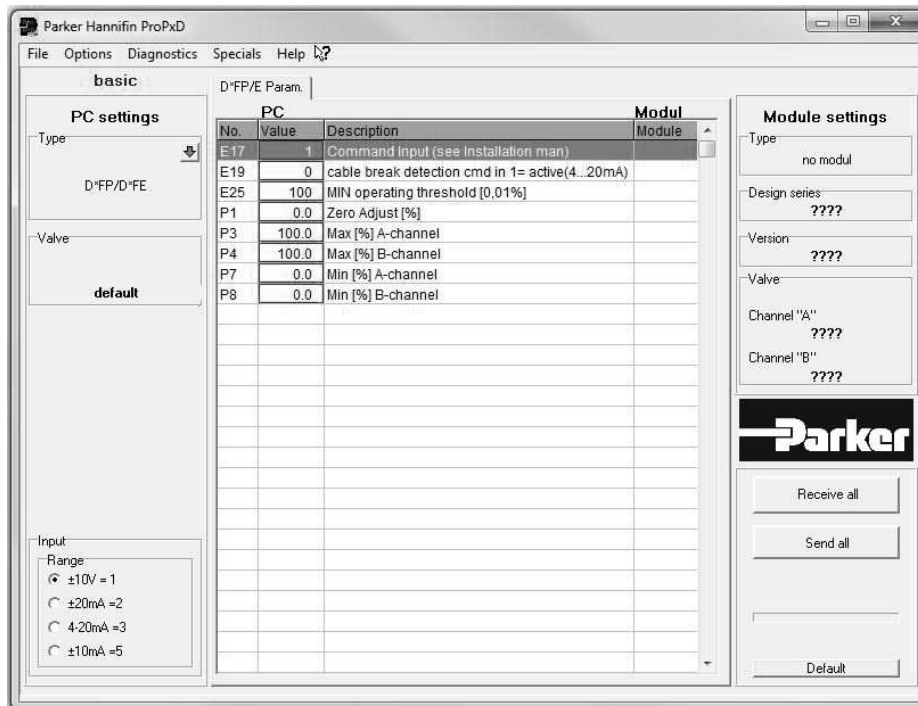

- Comfortable editing of valve parameters
- Saving and loading of customized parameter sets
- Executable with all Windows® operating systems from Windows® XP upwards
- Simple communication between PC and valve electronics via serial interface RS232C

The valve electronics cannot be connected to a PC with a standard USB cable – this can result in damages of PC and/or valve electronics.

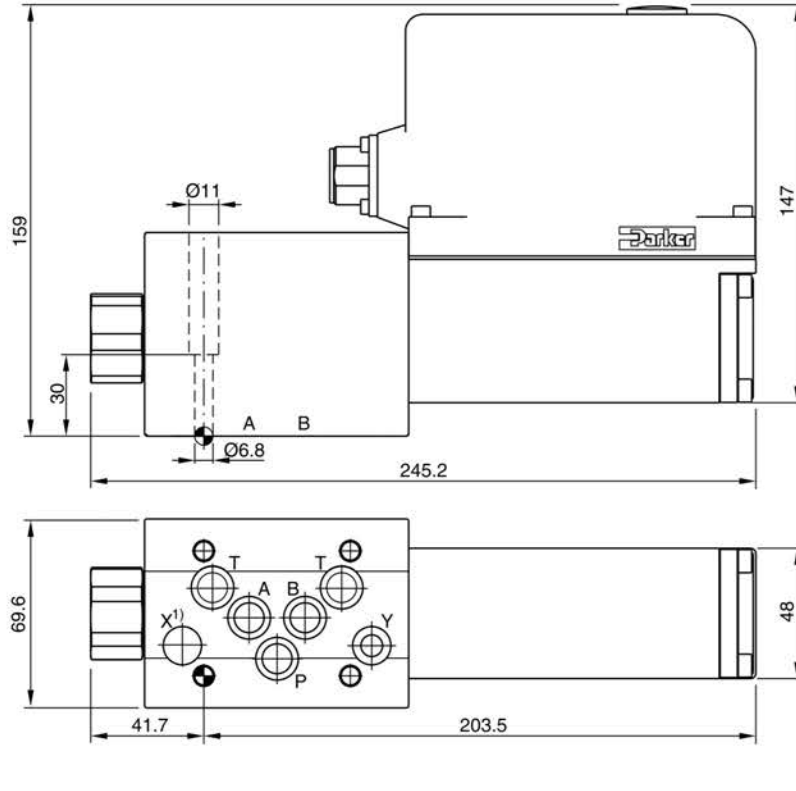
The parametrizing cable may be ordered under item no. 40982923.

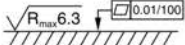

3

Surface finish	 Kit	 Kit	 Kit	 Kit
	BK385	4xM6x40 ISO 4762-12.9	13.2 Nm ±15 %	NBR: SK-D3FP FPM: SK-D3FP-V HFC: SK-D3FP-H

1) O-ring recess diameter on valve body.