

RE 21468

Edition: 2024-02

Replaces: 2022-09

Check valve, pilot operated

Type SV and SL

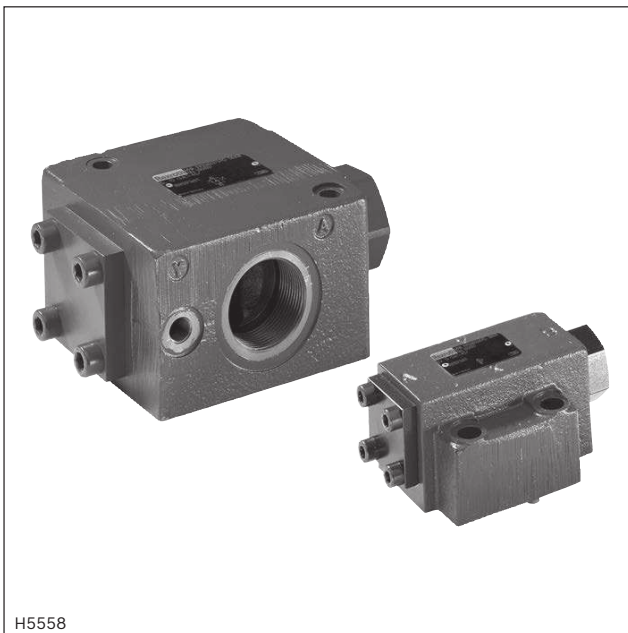

- ▶ Size 10, 20, and 32
- ▶ Component series 4X
- ▶ Maximum operating pressure 350 bar
- ▶ Maximum flow 550 l/min

Features

- ▶ For subplate mounting
- ▶ Porting pattern
 - ISO 5781-06-07-0-16 (NG10)
 - ISO 5781-08-10-0-16 (NG20)
 - ISO 5781-09-13-0-16 (NG32)
- ▶ For threaded connection
- ▶ Attachment possibility for directional spool valve or directional seat valve, optional
- ▶ With internal or external pilot oil return, optional
- ▶ Version with pre-opening for dampened release, optional
- ▶ Various cracking pressures, optional
- ▶ Check valve cartridge separately available
- ▶ Corrosion-resistant housing design, optional

Contents

Features	1
Ordering code	2
Symbols	3
Function, section	4, 5
Technical data	6, 7
Characteristic curves	8 ... 11
Dimensions	12 ... 16
Circuit example	16
Inductive position switch	17
Further information	18

Ordering code

01	02	03	04	05	06	07	08	09	10	11	12	13	
S						-	4X	/			-		

01	Check valve	S
02	Internal pilot oil return	V
	External pilot oil return	L
03	Size 10	10
	Size 20	20
	Size 32	30
Type of connection		
04	Subplate mounting	P
	Threaded connection	G
05	With pre-opening	A
	Without pre-opening	B
Cracking pressure (see characteristic curves page 8)		
06	1.5 bar (NG10) and 2.5 bar (NG20, NG32)	1
	3.0 bar (NG10) and 5.0 bar (NG20, NG32)	2
	6.0 bar (NG10), 7.5 bar (NG20) and 8.0 bar (NG32)	3
	10.0 bar (NG10, NG20, NG32)	4
07	Component series 40 ... 49 (40 ... 49: Unchanged installation and mounting dimensions)	4X
08	Without attachment possibility for directional spool valve or directional seat valve	No code
	With attachment possibility for directional spool valve or directional seat valve (NG6) (only version "SL" and NG20 and NG32)	6U
Spool position monitoring (for more information, see page 17)		
09	Without position switch	No code
	With position switch (only version "B3")	QMG24
Seal material (observe compatibility of seals with hydraulic fluid used, see page 7)		
10	NBR seals	M
	FKM seals	V
Corrosion resistance		
11	None	No code
	Improved corrosion protection (240 h salt spray test according to EN ISO 9227)	J3
Connection thread (versions with threaded connection "G" only)		
12	Pipe thread "G" according to ISO 228-1	No code
	Pipe thread "UNF/UN" according to ANSI/ASME B 1.1	/12
13	Further details in the plain text	*

 **Notice:** ◇ = Preferred type

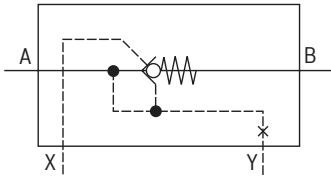
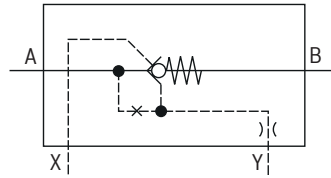
Symbols
Version "SV" (internal pilot oil return)

Version "SL" (external pilot oil return)

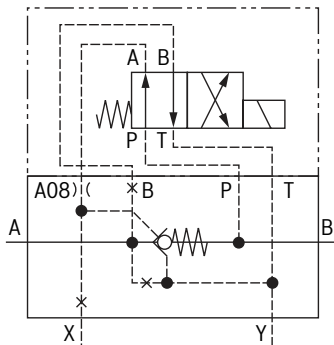
Version "SL ...6U"

With directional spool valve type 4WE 6 D...

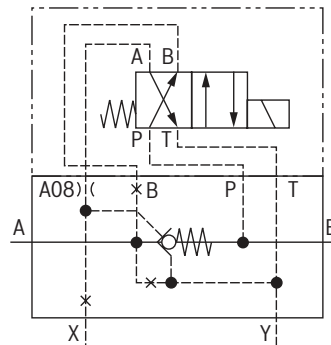

With directional spool valve type 4WE 6 Y...



With directional seat valve type M-3SEW 6 C...

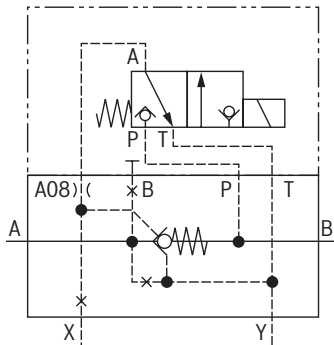

With directional seat valve type M-3SEW 6 U...

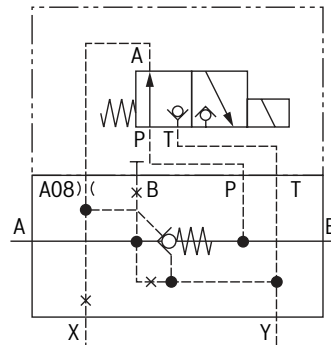

Function, section

The check valves type SV and SL are releasable check valves for subplate mounting or threaded connection. They are used for the leakage-free blocking of an actuator port, also in case of longer standstill times.

The valves basically consist of a housing (1), a seat poppet (2), a compression spring (3), a control spool (4) as well as of an optional pre-opening as ball seat valve (5).

The flow can pass through the seat valve without external pilot pressure in the direction A→B (condition: $p_A > p_B$ + cracking pressure (compression spring)). In the opposite direction, the seat valve closes hydraulically tight.

A sufficiently high pilot pressure at port X moves the control spool (4) in the direction of the ball seat valve (5) (version "A") and pushes the seat poppet (2) out of its seat. This allows for a free flow in both directions (active keeping open).

In order to ensure that the seat valve actively opens, the pressure ratios on both sides of the control spool (4) are just as important as the area ratios at the control spool (4) or seat poppet (2).

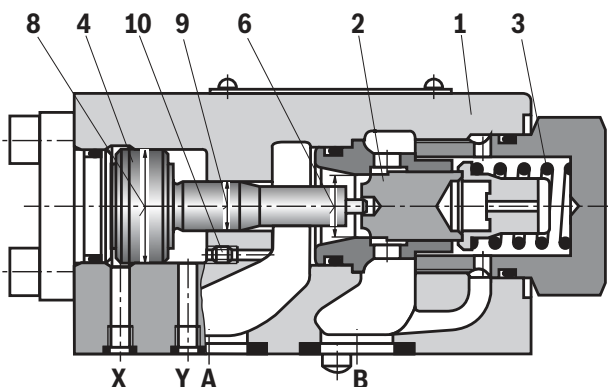

Type SL..PB.-4X... (with pilot oil return, without pre-opening)

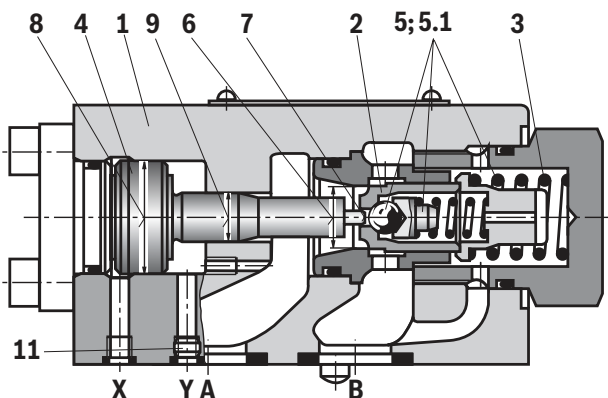

Type SV 10 PA.-4X... (without pilot oil return, with pre-opening)

This results in the following available options for the types

- ▶ SV (large annulus area A_3 (8) connected with p_A) or
- ▶ SL (small annulus area A_4 (9))

as well as for the versions with pre-opening "A" and without pre-opening "B".

Version "A" (with pre-opening)

This valve is provided with an additional pre-opening. By pressurization at the X port, the control spool (4) is moved to the right. As a result, the ball (5) is pushed off the seat first followed by the seat poppet (2).

Notice:

- ▶ Version "A":
 - The two-stage set-up with an increased control open ratio means even low pilot pressure can be unloaded securely.
 - Avoidance of switching shocks due to dampened decompression of the pressure volume on the actuator side.
- ▶ Version "B":
 - In case of valves without pre-opening, the included pressure volume may be unloaded suddenly. Resulting switching shocks may lead to premature wear on installed components, as well as noise formation.

The modification of type SV to type SL is possible by exchange of plugs (10) and (11). One of the two plugs must always be installed.

NG	Plug (10)	Plug (11)
10	M3	M6
20	M4	M6
32	M4	M6

- 6 Area A_1 (seat poppet)
- 7 Area A_2 (ball)
- 8 Area A_3 (control spool)
- 9 Area A_4 (control spool)

Function, section: version "6U" (with built-on directional valve)

At direct operated, releasable check valves type SL with built-on directional valve, the control spool (4) may be controlled directly via the directional valve to open the seat poppet (2) against the system pressure, i.e. the blocking direction.

 **Notice:**

When ordering the directional valve, please observe the different position of port A in versions "P" and "G" (porting pattern rotated by 180° in version "G", see pages 14 and 15).

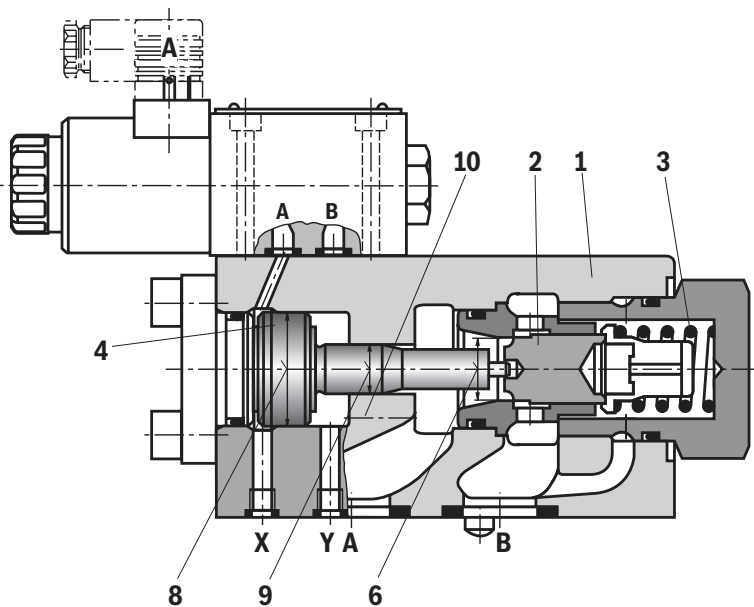

- 6 Area A_1 (seat poppet)
- 8 Area A_3 (control spool)
- 9 Area A_4 (control spool)

Type SL..PB.-4X/6U... (with pilot oil return, without pre-opening)

Technical data

(for applications outside these values, please consult us!)

General					
Sizes	NG		10	20	32
Type of connection	Subplate mounting; threaded connection				
Porting pattern		ISO 5781-06-07-0-16	ISO 5781-08-10-0-16	ISO 5781-09-13-0-16	
Weight	▶ Subplate mounting "P"	kg	1.8	4.7	7.8
	▶ Threaded connection "G"	kg	2.1	5.4	10
Installation position	Any				
Ambient temperature range	°C	-20 ... +80 (NBR seals) -15 ... +80 (FKM seals)			
Storage temperature range	°C	+5 ... +40			
MTTF _D values according to EN ISO 13849	Years	150 (for further details see data sheet 08012)			
Conformity	▶ RoHS Directive	2011/65/EU ¹⁾			

Hydraulic					
Maximum operating pressure	▶ Subplate mounting "P"	bar	350	315	315
	▶ Threaded connection "G"	bar	350	315	315
Hydraulic fluid	See table below				
Hydraulic fluid temperature range	°C	-20 ... +80 (NBR seals) -15 ... +80 (FKM seals)			
Viscosity range	mm ² /s	2.8 ... 500			
Maximum admissible degree of contamination of the hydraulic fluid; cleanliness class according to ISO 4406 (c)	Class 20/18/15 ²⁾				
Maximum flow	l/min	See characteristic curves on page 8 and 10			
Pilot volume	▶ Port X	cm ³	2.5	10.8	19.27
	▶ Port Y (version "L" only)	cm ³	2.0	9.6	17.5
Pilot pressure	▶ Subplate mounting "P"	bar	5 ... 350	5 ... 315	5 ... 315
	▶ Threaded connection "G"	bar	5 ... 350	5 ... 315	5 ... 315
Direction of flow	Free from A → B, from B → A by opening				
Control areas (areas according to sectional drawing on pages 4 and 5)	▶ Area A ₁	cm ²	1.33	3.46	5.72
	▶ Area A ₂	cm ²	0.33	0.7	1.33
	▶ Area A ₃	cm ²	3.8	10.17	16.61
	▶ Area A ₄	cm ²	0.79	1.13	1.54

¹⁾ The product fulfills the substance requirements of the RoHS Directive 2011/65/EU.

²⁾ The cleanliness classes specified for the components must be adhered to in hydraulic systems. Effective filtration prevents faults and at the same time increases the life cycle of the components.

Technical data

(for applications outside these values, please consult us!)

Hydraulic fluid	Classification	Suitable sealing materials	Standards	Data sheet
Mineral oils	HL, HLP, HLPD, HVLP, HVLPD	NBR, FKM	DIN 51524	90220
Bio-degradable	▶ Insoluble in water	HETG	ISO 15380	90221
		HEES		
	▶ Soluble in water	HEPG	ISO 15380	
Flame-resistant	▶ Water-free	HFDU (glycol base)	ISO 12922	90222
		HFDU (ester base)		
		HFDR		
	▶ Containing water	HFC (Fuchs: Hydrotherm 46M, Renosafe 500; Petrofer: Ultra Safe 620; Houghton: Safe 620; Union: Carbide HP5046)	ISO 12922	90223



Important information on hydraulic fluids:

- ▶ For further information and data on the use of other hydraulic fluids, please refer to the data sheets above or contact us.
- ▶ There may be limitations regarding the technical valve data (temperature, pressure range, life cycle, maintenance intervals, etc.).
- ▶ The ignition temperature of the hydraulic fluid used must be 50 K higher than the maximum surface temperature.
- ▶ **Bio-degradable and flame-resistant – containing water:**
If components with galvanic zinc coating (e.g. version "J3" or "J5") or parts containing zinc are used, small amounts of dissolved zinc may get into the hydraulic system and cause accelerated aging of the hydraulic fluid. Zinc soap may form as a chemical reaction product, which may clog filters, nozzles and solenoid valves – particularly in connection with local heat input.

▶ Flame-resistant – containing water:

Due to the increased cavitation tendency with HFC hydraulic fluids, the life cycle of the component may be reduced by up to 30% as compared to the use with mineral oil HLP. In order to reduce the cavitation effect, it is recommended – if possible considering conditions specific to the installation – to back up the return flow pressure in ports T to approx. 20% of the pressure differential at the component.

Characteristic curves: Subplate mounting
 (measured with HLP46, $\vartheta_{oil} = 40 \pm 5 \text{ }^\circ\text{C}$)

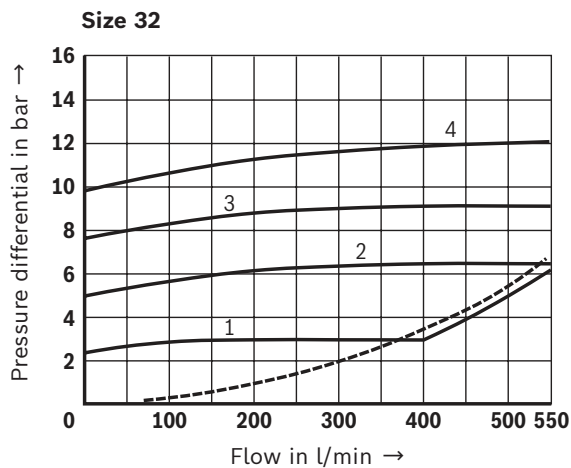
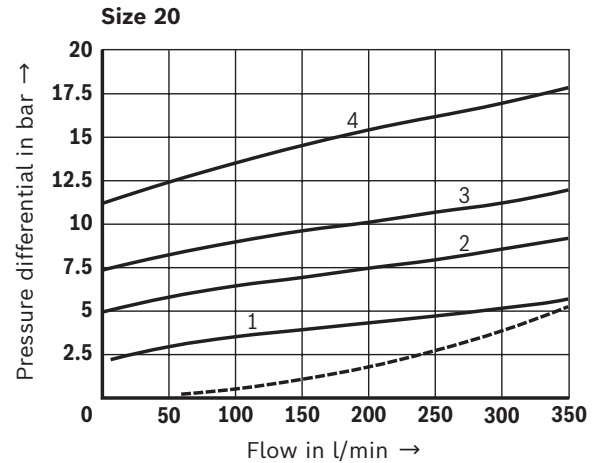
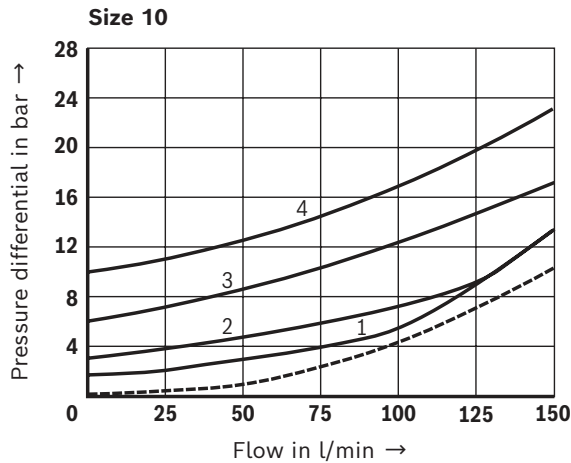
 Δp - q_V characteristic curves

Cracking pressure in bar

	NG10	NG20	NG32
1	1.5	2.5	2.5
2	3	5	5
3	6	7.5	8
4	10	10	10

 **Notice:** Typical characteristic curves which are subject to tolerance variations.

Characteristic curves: Subplate mounting
 (measured with HLP46, $\vartheta_{oil} = 40 \pm 5 \text{ } ^\circ\text{C}$)

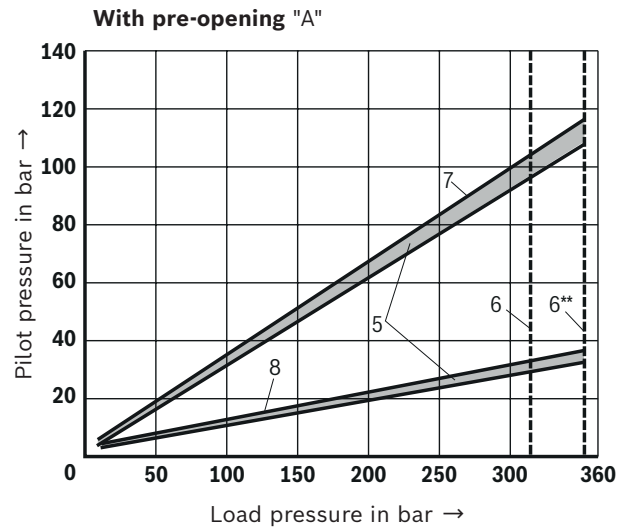
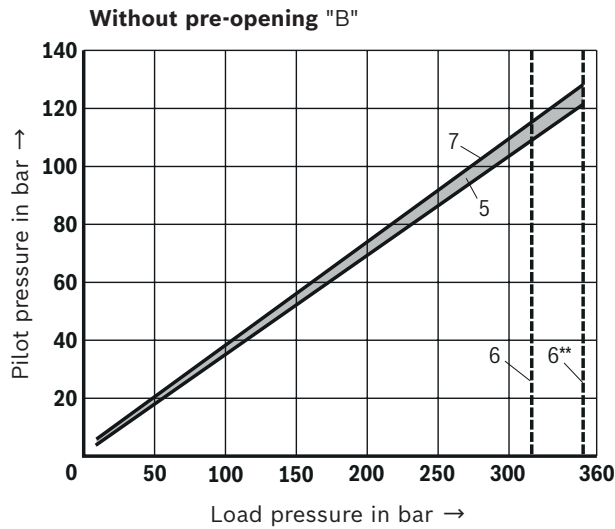
Pilot pressure/load pressure characteristic curves



- 5 Pilot pressure range
- 6 Limit value 315 bar
- 6** Limit value 350 bar
- 7 Valve poppet
- 8 Pre-opening

 **Notice:** Typical characteristic curves which are subject to tolerance variations.

10/20 SV; SL | Check valve

Characteristic curves: Threaded connection
 (measured with HLP46, $\vartheta_{oil} = 40 \pm 5 \text{ }^\circ\text{C}$)

Δp - q_v characteristic curves

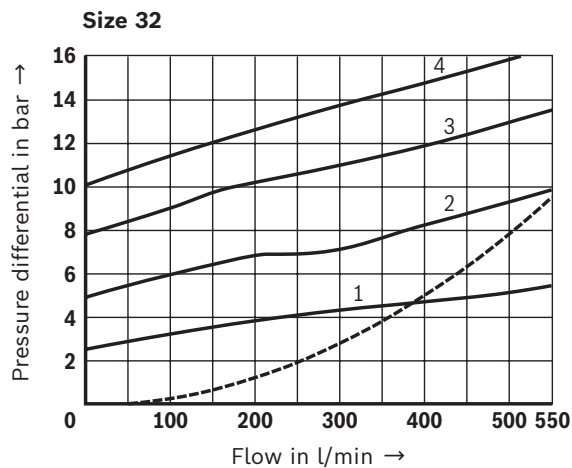
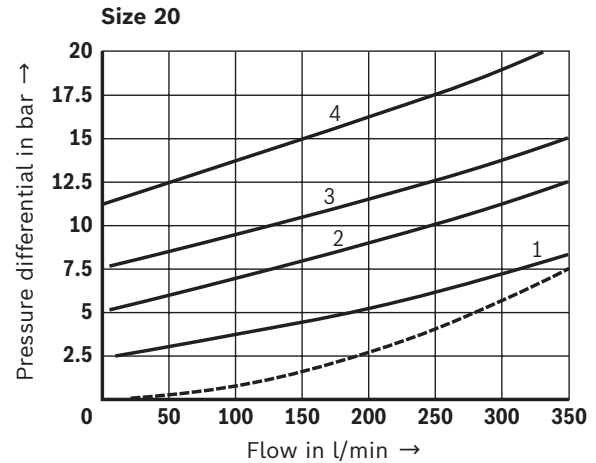
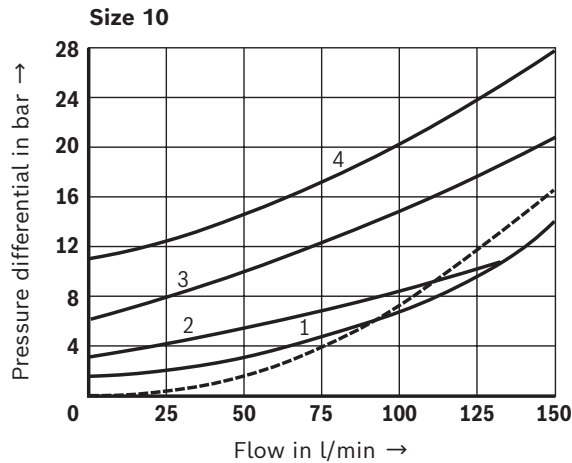

— A \rightarrow B
 - - - B \rightarrow A

Cracking pressure in bar

	NG10	NG20	NG32
1	1.5	2.5	2.5
2	3	5	5
3	6	7.5	8
4	10	10	10

 **Notice:** Typical characteristic curves which are subject to tolerance variations.

Characteristic curves: Threaded connection
 (measured with HLP46, $\vartheta_{oil} = 40 \pm 5 \text{ } ^\circ\text{C}$)

Pilot pressure/load pressure characteristic curves

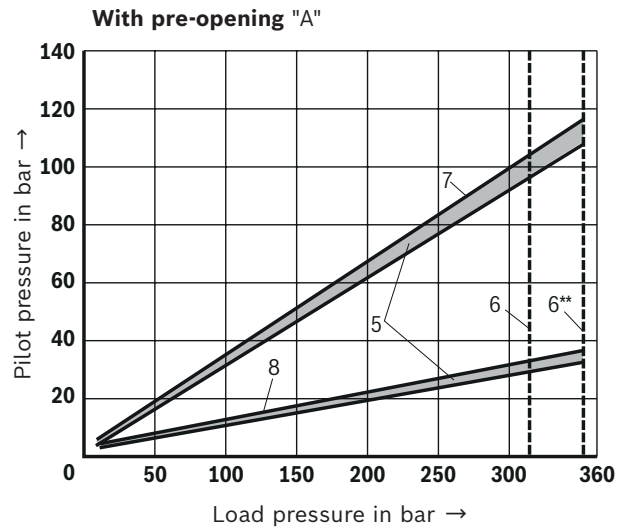
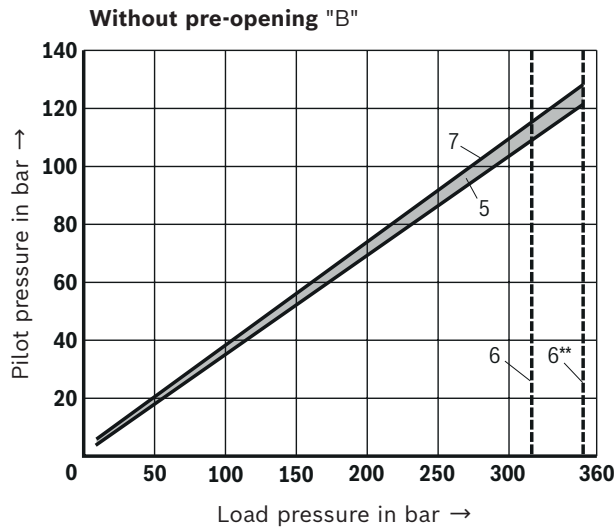

- 5 Pilot pressure range
- 6 Limit value 315 bar
- 6** Limit value 350 bar
- 7 Valve poppet
- 8 Pre-opening

 **Notice:** Typical characteristic curves which are subject to tolerance variations.

12/20 **SV; SL** | Check valve

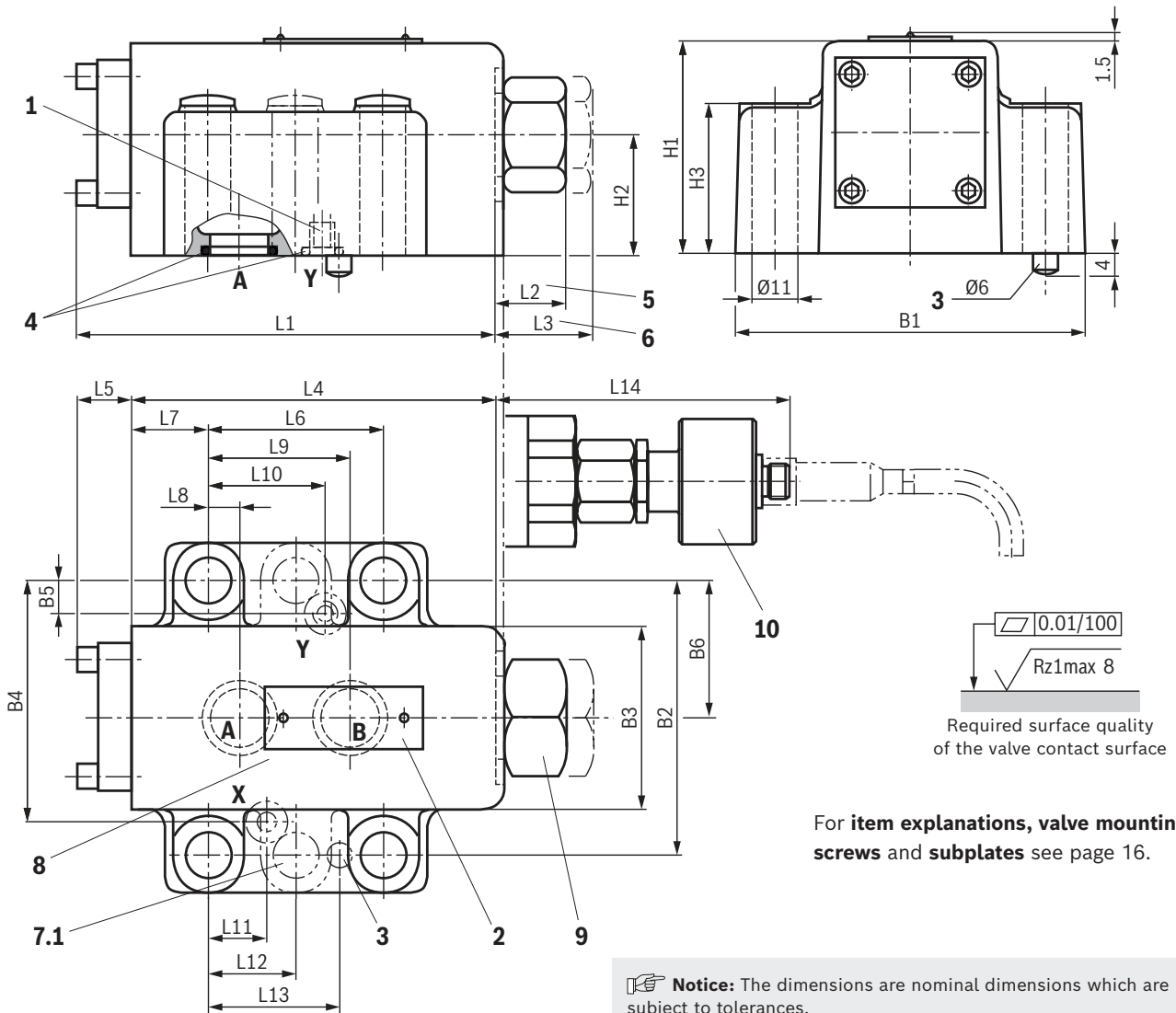
Dimensions: Subplate mounting
 (dimensions in mm)

Type	NG	L1	L2	L3	L4	L5	L6	L7	L8	L9	L10	L11	L12	L13	L14
SV	10	100.8	15.5	15.5	87.8	13	42.9	18.5	7.2	35.8	-	21.5	-	31.8	100
	20	135	17.7	45.7	117	18	60.3	27.5	11.1	49.2	-	20.6	-	44.5	89.5
	32	156.1	36.1	46.1	134	22.1	84.2	39	16.7	67.5	-	24.6	42.1	62.7	112
SL	10	100.8	15.5	15.5	87.8	13	42.9	18.5	7.2	35.8	21.5	21.5	-	31.8	100
	20	135	17.7	45.7	117	18	60.3	27.5	11.1	49.2	39.7	20.6	-	44.5	89.5
	32	156.1	36.1	46.1	134	22.1	84.2	39	16.7	67.5	59.5	24.6	42.1	62.7	112

Type	NG	B1	B2	B3	B4	B5	H1	H2	H3	B6
SV	10	84	66.7	44	58.8	-	51	29	36	33.4
	20	100	79.4	61	73	-	78	45	58	39.7
	32	118	96.8	75	92.8	-	85	42.5	70	48.4
SL	10	84	66.7	44	58.8	7.9	51	29	36	33.4
	20	100	79.4	61	73	6.4	78	45	58	39.7
	32	118	96.8	75	92.8	3.8	85	42.5	70	48.4

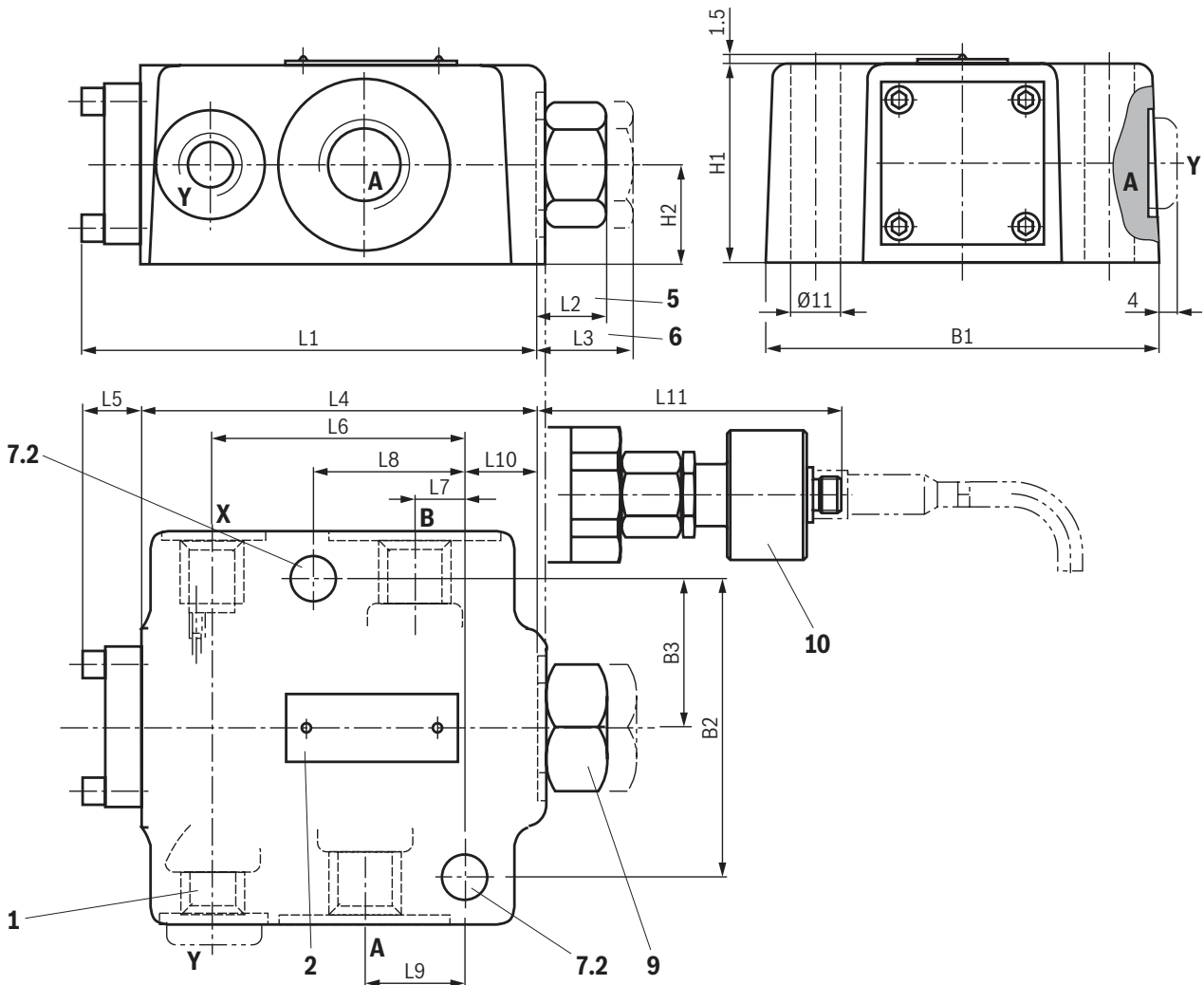
Dimensions: Threaded connection
 (dimensions in mm)

Connections

NG	A, B		X, Y	
	"G"	"UNF/UN"	"G"	"UNF/UN"
10	G 1/2	3/4-16 UNF	G 1/4	7/16-20 UNF
20	G1	1 5/16-12 UN		
32	G 1 1/2	1 7/8-12 UN		

 **Notice:** The dimensions are nominal dimensions which are subject to tolerances.

Type	NG	L1	L2	L3	L4	L5	L6	L7	L8	L9	L10	L11	B1	B2	B3	H1	H2
SV	10	100.8	15.5	15.5	87.8	13	56.5	10.5	33.5	22.5	17.3	100	87	66.7	33.4	44	22
	20	133	17.7	47.7	115	18	74.5	17	50.5	36	27	89.5	105	79.4	39.7	68	34
	32	156.1	36.1	46.1	134	22.1	101	24	84	49	18	112	130	96.8	48.4	85	42.5
SL	10	100.8	15.5	15.5	87.8	13	56.5	10.5	33.5	22.5	17.3	100	87	66.7	33.4	44	22
	20	133	17.7	47.7	115	18	74.5	17	50.5	36	27	89.5	105	79.4	39.7	68	34
	32	156.1	36.1	46.1	134	22.1	101	24	84	49	18	112	130	96.8	48.4	85	42.5

For **item explanations, valve mounting screws and connection adapters** see page 16.

14/20 SV; SL | Check valve

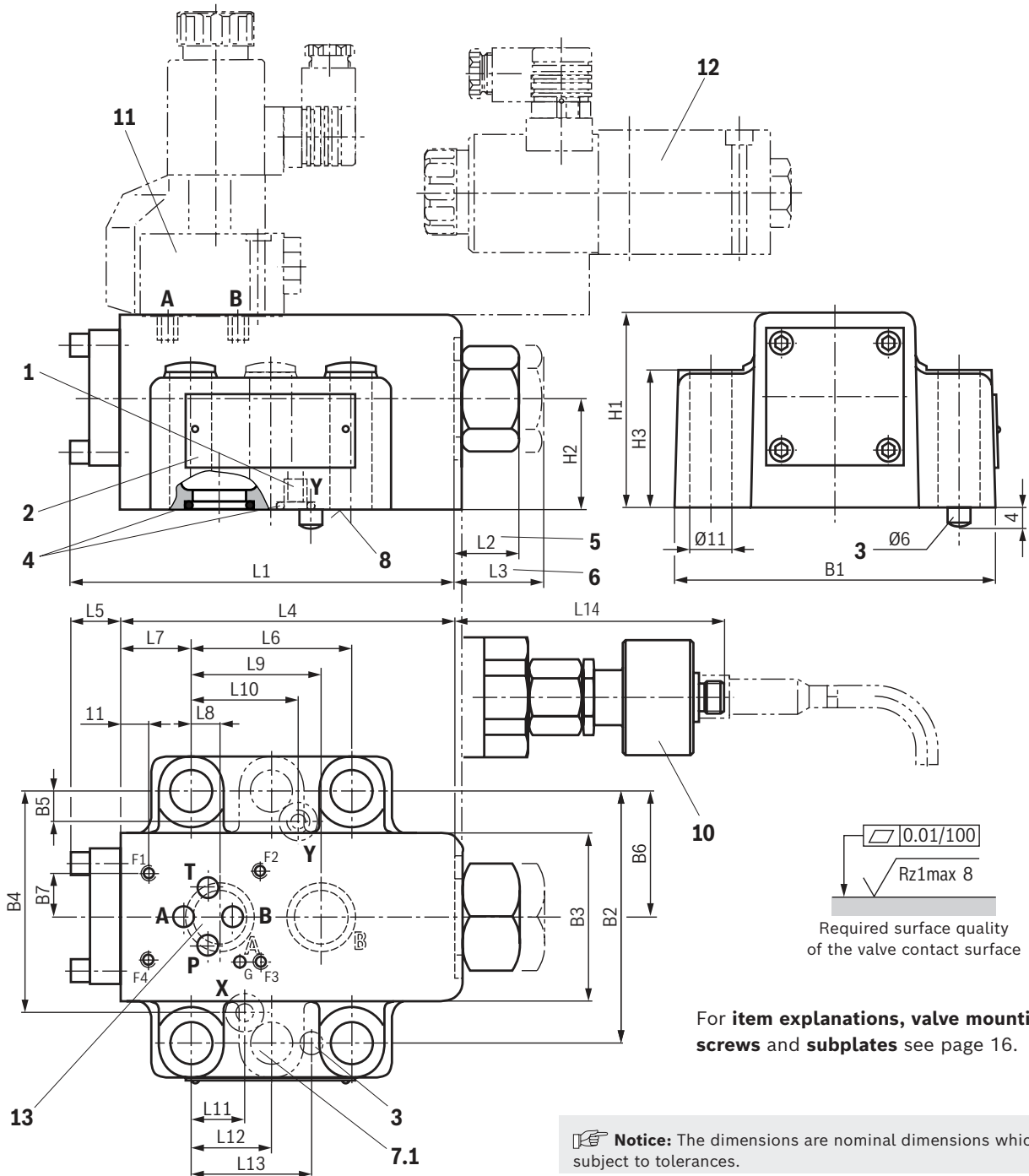
Dimensions: Version "6U", subplate mounting
 (dimensions in mm)

NG	L1	L2	L3	L4	L5	L6	L7	L8	L9	L10	L11	L12
20	135	45.7	21.7	117	18	60.3	27.5	11.1	49.2	39.7	20.6	-
32	156.1	36.1	46.1	134	22.1	84.2	39	16.7	67.5	-	24.6	42.1

NG	L13	L14	B1	B2	B3	B4	B5	B6	B7	H1	H2	H3
20	44.5	89.5	100	79.4	67	73	6.4	39.7	15.5	78	45	58
32	62.7	112	118	96.8	75	92.8	-	48.4	15.5	85	42.5	70

Bosch Rexroth AG, RE 21468, edition: 2024-02

Archivierung: 07/2024

Dimensions: version "6U", threaded connection
 (dimensions in mm)

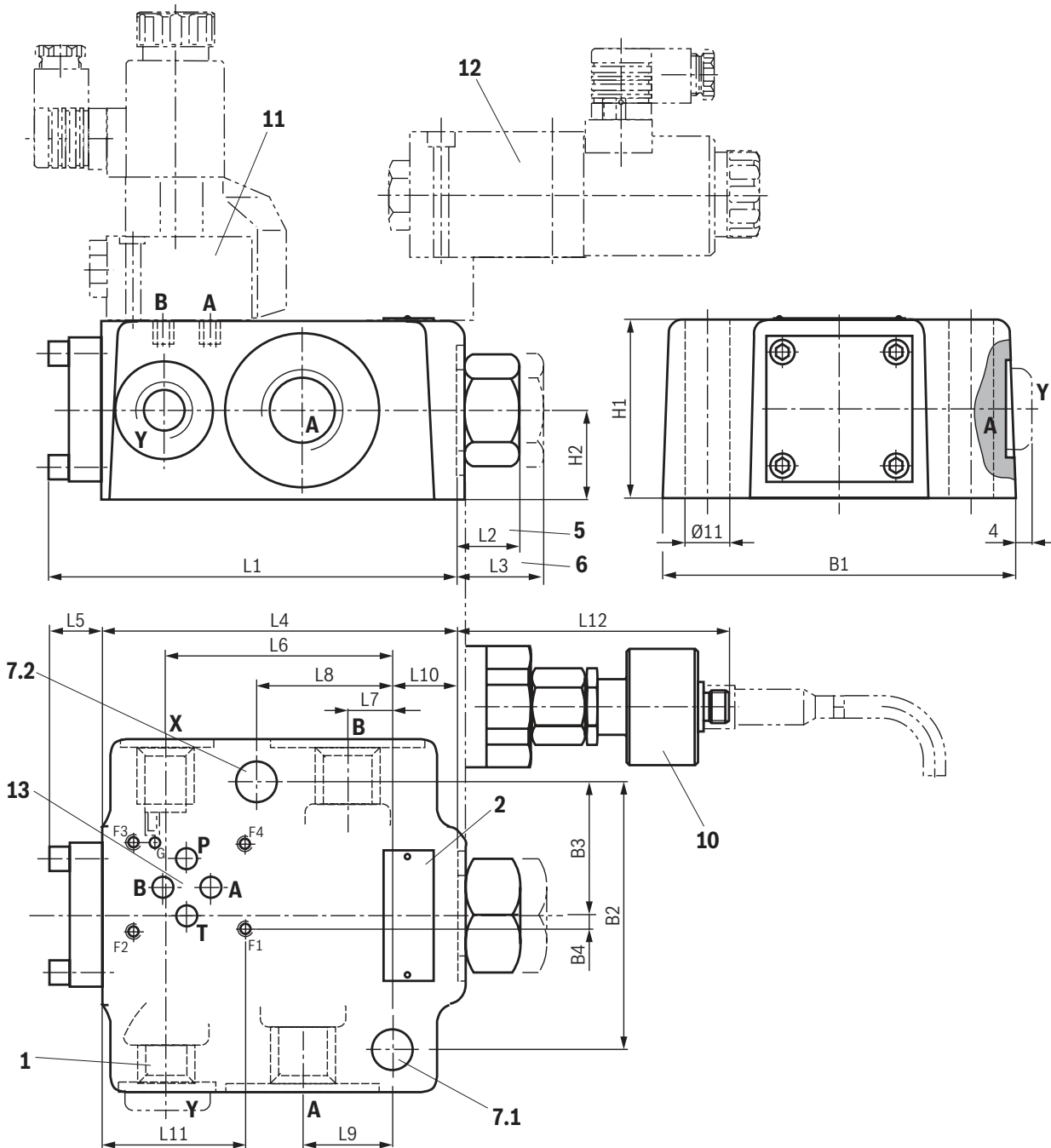

Connections

NG	A, B		X, Y	
	"G"	"UNF/UN"	"G"	"UNF/UN"
20	G 1	1 5/16-12 UN	G 1/4	7/16-20 UNF
32	G 1 1/2	1 7/8-12 UN		

 **Notice:** The dimensions are nominal dimensions which are subject to tolerances.

For **item explanations, valve mounting screws** and **connection adapters** see page 16.

NG	L1	L2	L3	L4	L5	L6	L7	L8	L9	L10	L11	L12	B1	B2	B3	B4	H1	H2
20	133	17.7	45.7	115	18	74.5	17	50.5	36	27	53	89.5	105	79.4	39.7	8.25	68	34
32	156.1	36.1	46.1	134	22.1	101	24	84	49	18	59	112	130	96.8	48.4	3.25	85	42.5

Dimensions

- | | |
|--|---|
| <ul style="list-style-type: none"> 1 Port Y at version "SL" (closed at version "SV") 2 Name plate 3 Locking pin 4 Identical seal rings for ports <ul style="list-style-type: none"> ▶ A and B ▶ X and Y 5 Valve with cracking pressure version "1" and "2" 6 Valve with cracking pressure version "3" and "4" 7.1 6 valve mounting bores at NG32 7.2 2 valve mounting bores | <ul style="list-style-type: none"> 8 Porting pattern according to ISO 5781 9 Version without position switch 10 Version with position switch "QMG24" (circuitry see page 17) 11 Directional seat valve type M-3SEW 6 ... (data sheet 22058) 12 Directional spool valve 4WE 6 ... (data sheet 23178) 13 Porting pattern according to ISO 4401-03-02-0-05 |
|--|---|

Valve mounting screws (separate order)

Size	Quantity	Hexagon socket head cap screws	Material number
10	4	ISO 4762 - M10 x 50 - 10.9 - flZn/nc/480h/C Friction coefficient $\mu_{\text{total}} = 0.09 \dots 0.14$; tightening torque $M_A = 58 \text{ Nm} \pm 10\%$	R913015580
20	4	ISO 4762 - M10 x 70 - 10.9 - flZn/nc/480h/C Friction coefficient $\mu_{\text{total}} = 0.09 \dots 0.14$; tightening torque $M_A = 58 \text{ Nm} \pm 10\%$	R913014772
32	6	ISO 4762 - M10 x 85 - 10.9 - flZn/nc/480h/C Friction coefficient $\mu_{\text{total}} = 0.09 \dots 0.14$; tightening torque $M_A = 58 \text{ Nm} \pm 10\%$	R913015584



Notice:

The specified tightening torques were calculated with the total friction coefficient $\mu = 0.09 \dots 0.14$; adapt to modified surfaces.

Subplates (separate order) see data sheet 45100.

Circuit example

Function: "load locking"; inlet side unloading

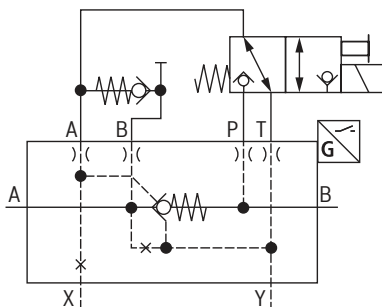

Inductive position switch type QM: Electrical connection

The electrical connection is realized via a 4-pole mating connector (separate order, see data sheet 08006) with connection thread M12 x 1.

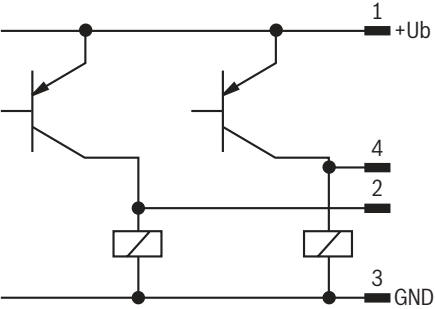
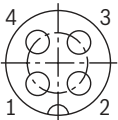
Connection voltage	24 V ^{+30%} _{-15%} , DC voltage								
Admissible residual ripple	≤ 10%								
Load capacity	Maximum 400 mA								
Switching outputs	PNP transistor outputs, load between switching outputs and GND								
									
Pinout	<table border="1"> <tr> <td>1</td> <td>+24 V</td> </tr> <tr> <td>2</td> <td>Switching output: 400 mA</td> </tr> <tr> <td>3</td> <td>0 V, GND</td> </tr> <tr> <td>4</td> <td>Switching output: 400 mA</td> </tr> </table>	1	+24 V	2	Switching output: 400 mA	3	0 V, GND	4	Switching output: 400 mA
1	+24 V								
2	Switching output: 400 mA								
3	0 V, GND								
4	Switching output: 400 mA								
									

Inductive position switch type QM: Switching logics

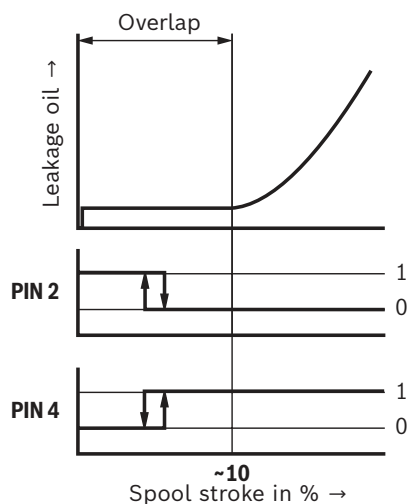

Further information

- ▶ Check valve, pilot operated (NG6) Data sheet 21460
- ▶ Directional spool valve Data sheet 23178
- ▶ Directional seat valve Data sheet 22058
- ▶ Subplates Data sheet 45100
- ▶ Hydraulic fluids on mineral oil basis Data sheet 90220
- ▶ Environmentally compatible hydraulic fluids Data sheet 90221
- ▶ Flame-resistant, water-free hydraulic fluids Data sheet 90222
- ▶ Flame-resistant hydraulic fluids – containing water (HFAE, HFAS, HFB, HFC) Data sheet 90223
- ▶ Mating connectors Data sheet 08006
- ▶ Reliability characteristics according to EN ISO 13849 Data sheet 08012
- ▶ Hexagon socket head cap screw, metric/UNC Data sheet 08936
- ▶ Hydraulic valves for industrial applications Operating instructions 07600-B
- ▶ Information on available spare parts www.boschrexroth.com/spc

Notes

Bosch Rexroth AG
Industrial Hydraulics
Zum Eisengießer 1
97816 Lohr am Main, Germany
Phone +49 (0) 93 52/40 30 20
my.support@boschrexroth.com
www.boschrexroth.com

© All rights reserved to Bosch Rexroth AG, also regarding any disposal, exploitation, reproduction, editing, distribution, as well as in the event of applications for industrial property rights.
The data specified above only serve to describe the product. As our products are constantly being further developed, no statements concerning a certain condition or suitability for a certain application can be derived from our information. The information given does not release the user from the obligation of own judgment and verification. It must be remembered that our products are subject to a natural process of wear and aging.

20/20 **SV; SL** | Check valve

Notes

Bosch Rexroth AG
Industrial Hydraulics
Zum Eisengießer 1
97816 Lohr am Main, Germany
Phone +49 (0) 93 52/40 30 20
my.support@boschrexroth.com
www.boschrexroth.com

© All rights reserved to Bosch Rexroth AG, also regarding any disposal, exploitation, reproduction, editing, distribution, as well as in the event of applications for industrial property rights.
The data specified above only serve to describe the product. As our products are constantly being further developed, no statements concerning a certain condition or suitability for a certain application can be derived from our information. The information given does not release the user from the obligation of own judgment and verification. It must be remembered that our products are subject to a natural process of wear and aging.