

HYDAC INTERNATIONAL



Fluid level gauge Fluid level sensor Temperature switch

FSA / FSK / TS

up to NG1000; up to PN 0.5; T = -40 °C to +160 °C

1. DESCRIPTION

1.1. GENERAL

FSA fluid level gauges, FSK fluid level sensors and TS temperature switches are designed to monitor and control the level of operating fluid.

The flexible product range means that many combinations are possible:

- **FSA:** Range of eleven evenly spaced sizes.
Visual thermometer with °C and °F scale.
Temperature gauge which measures the temperature of the operating fluid in the tank in °C. Dual scale in °C and °F available on request.
Simple standardised installation conditions.
- **FSA-IB:** shut-off of the fluid to the fluid level gauge via check valves.
Display of the current level by simultaneously pressing the upper and lower buttons on the check valves.
With the optional use of a thermometer, the current temperature of the fluid will also be shown.
Certified by Bureau Veritas (BV approval) and by American Bureau of Shipping (ABS approval).
- **FSAR:** Fluid level gauge in round design with pipe connections on both sides.
Thanks to the principle of communicating vessels, the gauge can be attached externally even at greater distances.
- **FSK:** Monitor the fluid level via an electrical signal.
Range of eleven evenly spaced sizes.
Simple standardised installation conditions.
Switching contact (sizes 127-381) designed as optionally normally closed (type O), normally open (type C) or changing (type W) contact – as changing contact (W) in sizes 076 and 500-1000.
Temperature gauge which measures the temperature of the operating fluid in the tank in °C and °F.
Option: line marking on sight tube and float.
Better visual fluid level monitoring possible with red float.
- **FSK-2SP:** Monitoring of the minimum or maximum fluid level.
Two additional alternative switching points for size 254 and above.
Optional: line markings on inspection tube.
- **FSK-V:** Switch points can be positioned variably, additional alternative switch points possible.
Switching contact designed as changing contact, opens or closes at switching level.
Riser tube made of glass.
Optional, 3-pole AMP plug (Super Seal).
Optional: line markings on inspection tube.
- **TS:** three nominal temperatures possible: 60 °C, 70 °C and 80 °C.
Can be easily fitted into the FSA and FSK.
Simple, standardised mounting (FSA/K).
Non-corroding surfaces.
- **Accessories**
TFP 100: Temperature sensor with a measurement range of -40 °C to +125 °C.
Measuring resistor designed as 4-conductor with standardised electrical connection
ABK / ABV: These shut-off elements allow the connections to be blocked for maintenance work or for making changes to the display system (FSA/FSK), without any tank draining required.



1.2. FUNCTION

FSA

By using the FSA, the fluid level can be easily seen on the outside of the tank. The fluid enters the unit via the lower connection bore and is clearly visible in the tube. By selecting the right size, the particular fluid level can be monitored.

FSK

By using the FSK, the fluid level is monitored via an electrical switching signal. This switch signal can be used for a warning or to control the level. The fluid enters the unit via the lower connection bore and pushes a float up the tube. The float now shows the level of the fluid in the tank. If the level of the fluid drops again, the float will activate a switch contact. For the NO switch (type C) the circuit will then be closed, for the NC switch (type O) the circuit will be opened.

The special dual switching model (type W) offers two possibilities. It can be used either to close on contact or to open on contact.

TS

The TS is a very useful additional option to the FSA and FSK products. However, it also has a useful application as a separate accessory for systems.

Once fitted, the temperature sensor of the TS is surrounded by operating fluid. When the nominal temperature is reached, a contact opens and the circuit is broken.

This switching process can be used either as an alarm or to monitor the temperature.

When the temperature of the fluid drops by approx. 15 K, the circuit closes again.

TFP

Based on the principle of voltage drop, the sensor provides an electrical signal as a value for the temperature.

A constant measurement flow is fed to the temperature sensor. The voltage change is roughly proportional to the change in resistance caused by the temperature – the higher the temperature, the greater the resistance.

Measurement errors caused by longer feed lines are avoided by using the 4-conductor connection.

ABK

This stop cock specially designed for the FSA/FSK has a plug that is guided in a valve casing and that can be turned from the outside. Turning it by 90° closes the connection opening of the FSA/FSK.

It is operated by screwdriver, from the side, above or below depending on the position of the ABK.

ABV

Screwing the adjusting screw deeper into the valve casing closes the connection opening of the FSA/FSK (the screw can be loosened again subsequently).

The screw is adjusted by means of an allen key (AF width 3).

1.3. APPLICATION

Fluid level gauges FSA, fluid level sensors FSK and temperature switches TS are used to monitor and control levels of operating fluid.

Areas of application are for example: Machine tools, system engineering, tanks for hydraulic, lubricating and cutting oils, and gearboxes.

1.4. NOTES

The upper viscosity limit is 2,000 mm²/s. It is not possible to combine a TS temperature switch with an FT temperature gauge.

To ensure correct functioning, pressure, viscosity and temperature specifications must be observed.

FSA/FSK

In the standard design not suitable for use with glycol and fluids containing glycol – the special design SO14 is recommended as a solution variant in such cases.

The display tube must not be brought into direct contact with cleaning agents or solvents which are used to clean containers / tanks. Prior damage/new damage of the display tube may lead to failure of the FSA/FSK.

FSK

Depending on the fluid level of the tank, the following switching logic applies for the fluid level monitor with NC and NO contacts.

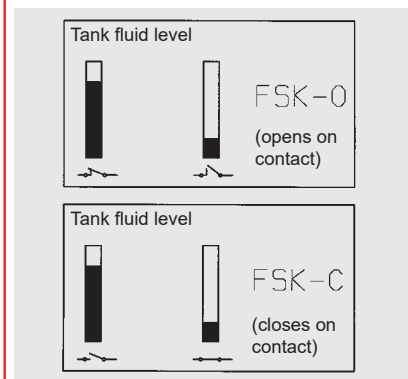

In each case the switching logic of the fluid level sensor starts with a full tank. For the NC version the switching contact opens when the fluid level drops below the switching level. Correspondingly, in the NO version, the switching contact closes when the fluid level drops below the switching level.

With inductive or capacitive loads, suitable protective circuits must be used.

2. TECHNICAL CHARACTERISTICS

2.1. GENERAL

2.1.1 Designation and Symbol

Fluid level gauge FSA

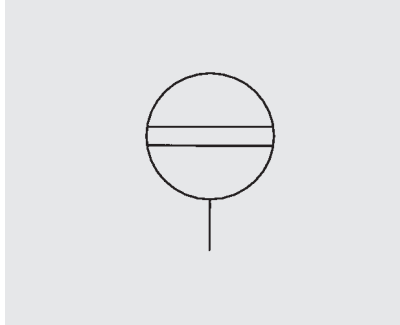

Fluid level sensor FSK

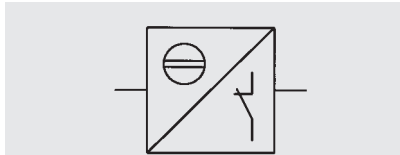

O - N/C contact

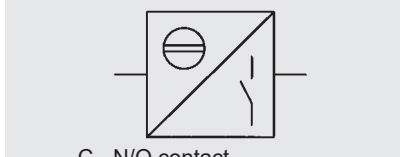

C - N/O contact

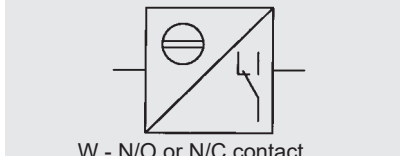

W - N/O or N/C contact

Temperature switch TS

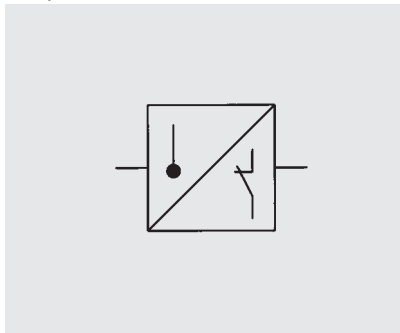

2.1.2 Model code for FSA

(also order example)

FSA - 076 - 2 . X / FT200 / 12 ...

Designation

FSA = fluid level gauge

Nominal size (≅ centre distance of bolts)

076; 127; 176; 254; 381

Seal material

1 = NBR (Perbunan)
2 = FKM (Viton)
5 = EPDM (on request)

Series

(specified by manufacturer)

Additional thermometer function

- = no additional function
T = thermometer in display tube
FF = prepared for temperature probe
FT 100 = temperature probe 100 mm
FT 200 = temperature probe 200 mm
FT 300 = temperature probe 300 mm
TS 60 = temperature switch nominal temperature 60 °C
TS 70 = temperature switch nominal temperature 70 °C
TS 80 = temperature switch nominal temperature 80 °C
TFP 100 = temperature probe -40 °C to +125 °C

Installation conditions (Banjo bolt thread)

12 = M12 (standard)
10 = M10 (not on TS)

Special designs

SO2 = with glass tube (round design), aluminium connectors
SO7 = frame, mounting bolts and nuts made from stainless steel*
SO8 = mounting bolts and nuts made from stainless steel*
SO14 = with glass tube, plastic connectors (PA)
SO19 = with green hollow ball, without contrast sheet
SO32 = with glass tube (round design), aluminium connectors; frame, mounting bolts and nuts made from stainless steel*
SO65 = FSA – standard, but without mounting nuts or sealing washers
SO67 = FSA – standard, but without mounting nuts
SO79 = with side viewing window

* only for size M12

2.1.3 Model code for FSA-IB

(also order example)

FSA - 254 - 2 . 0 / T / 12 SO7/SO8 2xIB ...

Designation

FSA = fluid level gauge

Nominal size (≅ centre distance of bolts)

076; 127; 176; 254; 381;
500; 600; 700; 800; 900; 1000

Seal material

1 = NBR (Perbunan)
2 = FKM (Viton)

Design of riser tube

0 = round

Additional thermometer function

- = no additional function
T = thermometer

Installation conditions (Banjo bolt thread)

12 = M12

Special designs

SO2 = with glass tube, aluminium connectors and round design
SO7 = frame, mounting bolts and nuts made from stainless steel
SO78 2xIB = with 2x bolts FSA/K-M12 V ISOLATOR bolt

Certification

BV = BV approval (sizes 076–1000)
ABS = ABS approval (sizes 076–381)

2.1.4 Model code for FSA 500-1000
 (also order example)

FSA - 1000 - 2 . 0 / - / 12 ... Ø19 ...
Designation

FSA = fluid level gauge

Nominal size (\cong centre distance of bolts)

500; 600; 700; 800; 900; 1000

Seal material

1 = NBR (Perbunan)

2 = FKM (Viton)

Design of riser tube

0 = round

Additional thermometer function

- = no additional function

FT = temperature probe

Installation conditions (Banjo bolt thread)

12 = M12 (standard)

Tank seal

... = flat seal (no entry required)

OR = O-ring

Diameter of riser tube

Ø19 = 19 mm

Special designs

SO2 = with glass tube (round design), aluminium connectors

2.1.5 Model code for FSAR
 (also order example)

FSAR - 137 - 1 . 0 / - / 12LR - 4SF ...
Designation

FSAR = fluid level gauge with pipe connection

Nominal size (\cong indication range)

088; 137; 215; 342

Seal material

1 = NBR (Perbunan)

2 = FKM (Viton)

Design of riser tube

0 = round

Additional function

- = hollow ball Ø 10

Installation conditions (pipe connection)

12LR = 12LR on both sides

Quantity of viewing windows

4SF = viewable from 4 sides

Design

No entry = without mounting nut

MUTTER = with mounting nut

2.1.6 Model code for FSK
 (also order example)

FSK - 127 - 2 . X / O / FT200 / 12 / ...
Designation

FSK = fluid level sensor

Nominal size (\cong centre distance of bolts)

127; 176; 254; 381

Seal material

2 = FKM (Viton)

Series

(specified by manufacturer)

Switching function

O = normally closed opens at the switching level
 C = normally open closes at the switching level
 W = changing opens or closes at the switching level (connector Z4 = standard)

Additional thermometer function

– = no additional function
 FT 100 = thermometer probe 100 mm
 FT 200 = thermometer probe 200 mm
 FT 300 = thermometer probe 300 mm
 TSL 60 = temperature switch nominal temperature 60 °C
 TSL 70 = temperature switch nominal temperature 70 °C
 TSL 80 = temperature switch nominal temperature 80 °C
 TFP 100 = temperature probe -40 °C to +125 °C

Installation conditions (Banjo bolt thread)

12 = M12 (standard)
 10 = M10 (not on TS)

Connector

No entry = 3-pole MPM (standard)
 Z4 = 4-pole Hirschmann (standard for changing contact)
 SEW = 4-pole M12x1 (sensor connector, horizontal)
 SO75 = 3-pole MPM, mounted at top (only size 127)
 SES = 4-pole M12x1 (sensor connector, vertical)
 Form B = special connection for device connector

2.1.7 Model code for FSK-076 / FSK-2SP / FSK-V
 (also order example)

FSK - 127 - 1 . O / W / - / 12 / 2SP
Designation

FSK = fluid level sensor
 FSKV = fluid level sensor with variable switching points

Nominal size (\cong centre distance of bolts)

076; 127; 176; 254; 381

Seal material

1 = NBR (Perbunan)

Series

(specified by manufacturer)

Switching function

W = changing contact, opens or closes at switching level

Additional thermometer function

– = no additional function (standard)

Installation conditions (Banjo bolt thread)

12 = M12

Switch points

1SP = 1 switch point
 2SP = 2 switch points (1x minimum, 1x maximum) (size 127 and above)
 Additional switch points on request

Connector

FSK-076-1SP: 3-pole M8x1 male
 FSK-2SP: 5-pole M12x1 male
 FSK-V: 3-pole M8x1 male

2.1.8 Model code for FSK 500-1000
 (also order example)

FSK - 1000 - 1 . 0 / W / - / 12 2SP Ø19
Designation

FSK = fluid level sensor

Nominal size (≅ centre distance of bolts)

500; 600; 700; 800; 900; 1000

Seal material

1 = NBR (Perbunan)

Series

(determined by manufacturer)

Switching function

W = changing contact, opens or closes at switching level

Additional thermometer function

– = no additional function

FT = temperature probe

Installation conditions (Banjo bolt thread)

12 = M12 (standard)

Switch points

1SP = 1 switch point

2SP = 2 switch points (1x minimum, 1x maximum)

Additional switch points on request

Diameter of riser tube

Ø19 = 19 mm

Connector

No entry = 3-pole M8x1 male (standard)

Special designs

SO2 = with glass tube (round design), aluminium connectors

2.1.9 Model code for TS
 (also order example)

TS - 70 / X / 12
Designation

TS = temperature switch (for FSA)

TS-L = temperature switch long (for FSK)

Nominal temperature

60 = 60 °C

70 = 70 °C

80 = 80 °C

Series

(specified by manufacturer)

Installation conditions (Banjo bolt thread)

12 = M12 (standard)

2.1.10 Form of construction

The devices are designed to be mounted directly on to the operating fluid tank.

2.1.11 Type of connection
FSA / FSK

The device is mounted using two banjo bolts. The connection bores can be either threaded holes or through holes (Ø 13, Ø 11).

FSAR

The device is mounted via a 12LR pipe connection on both sides, piping clamp or retaining plate.

TS

The temperature switch can be fitted to the FSA/FSK in place of the lower banjo bolt.

2.1.12 Installation

FSA – vertically on the tank wall

FSK – vertically on the container wall (connection plug at bottom of the container)

TS – instead of lower banjo bolt M12 (FSA)

TS-L – instead of lower banjo bolt M12 (FSK)

TFP – instead of lower banjo bolt M12 (FSA/FSK)

2.1.13 Weight

FSK076 - 0.22 kg	FSK500 - 0.69 kg
FSK127 - 0.21 kg	FSK600 - 0.79 kg
FSK176 - 0.23 kg	FSK700 - 0.85 kg
FSK254 - 0.26 kg	FSK800 - 0.93 kg
FSK381 - 0.30 kg	FSK900 - 1.00 kg
	FSK1000 - 1.14 kg
FSA076 - 0.17 kg	FSA500 - 0.68 kg
FSA127 - 0.19 kg	FSA600 - 0.75 kg
FSA176 - 0.21 kg	FSA700 - 0.84 kg
FSA254 - 0.24 kg	FSA800 - 0.92 kg
FSA381 - 0.29 kg	FSA900 - 0.99 kg
	FSA1000 - 1.13 kg

TS-... - 0.11 kg
TS-L-... - 0.13 kg
FT 200 - 0.03 kg
FT 300 - 0.04 kg
TFP 100 - 0.20 kg

2.1.14 Flow direction

Any

2.1.15 Ambient temperature

-20 °C to +80 °C

2.1.16 Materials
FSA / FSK

- Connectors and tube in high quality synthetic material
- Housing frame made from aluminium (steel or stainless steel on request)
- Soft seals in Viton (FKM) or Perbunan (NBR)
- Bolts, nuts and washers in steel (zinc-plated)
- Plug connections in high quality synthetic material (FSK)

FSA-IB

- Housing frame, bolts and nuts made of stainless steel
- Riser tube made of glass Ø 19

FSAR

- Frame made of aluminium
- Riser tube made of glass or plastic

FSA / FSK 500 - 1000

- Connectors made of aluminium
- Float gauge made from NBR

FSK-2SP

- Connectors made of aluminium / polyamide
- Frame made of aluminium
- Riser tube made of glass Ø 19

FSK-V

- Housing frame made of stainless steel
- Connectors made of aluminium / polyamide
- Riser tube made of glass Ø 19

TS / TS-L / TFP

- Housing with temperature sensor, washer and nut in steel (zinc-plated)
- Plug connections in high quality synthetic material

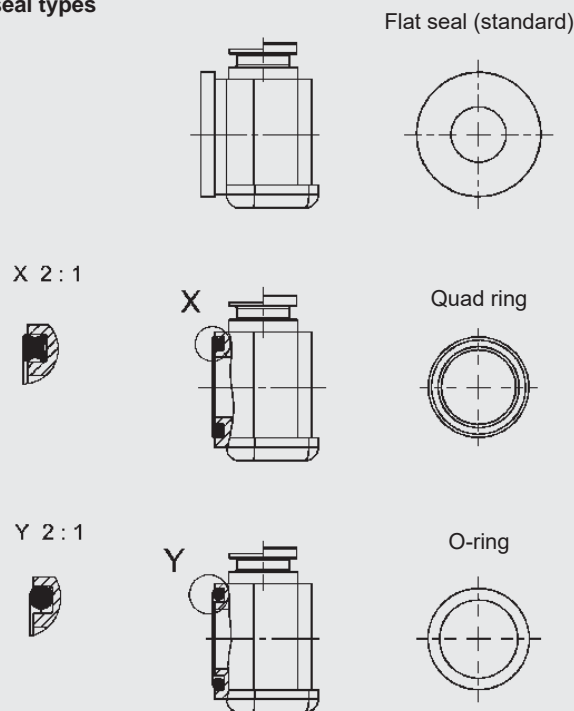
2.1.17 FSA seal types



2.2. HYDRAULIC DATA

2.2.1 **Nominal pressure**
max. 0.5 bar

2.2.2 **Operating fluids**
Mineral oil to DIN 51524 Part 1 and 2, water-oil emulsions and synthetic fluids, such as hydraulic fluids based on phosphate ester.
(other fluids on request)

2.2.3 **Temperature of operating fluid**
-20 °C to + 80 °C

2.2.4 **Range of thermometer scale**
FSA / FSK

Thermometer T for FSA:
+20 °C to +80 °C

Thermometer FT for FSA / FSK:
0 °C to +100 °C

2.3. ELECTRICAL CHARACTERISTICS FSK

2.3.1 Electrical functions

Type O / normally closed

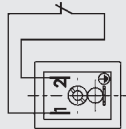

Type O / normally closed
(plug Z4 and form B)

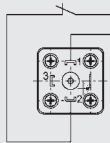

Type O / normally closed
(plug - SEW)

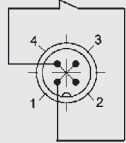

Type C / normally open

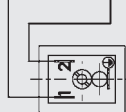

Type W / change over
(plug Z4 and form B)

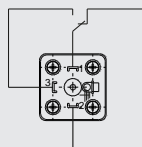

Type W / change over
(plug - SEW)

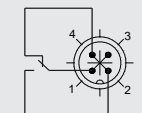

FSK-2SP

Type W / change over
As delivered, switching point at bottom activated by magnetic field.

Size 127, 254, 381

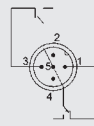

Contact assignment	bottom	top
Float setting		
Minimum	5 - 4	5 - 3
Maximum	5 - 1	5 - 2

Size 176

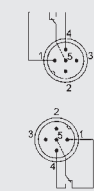

Contact assignment	top
Float setting	
Maximum	5 - 4

Contact assignment	bottom
Float setting	
Minimum	5 - 4

FSK-V

Type W / change over

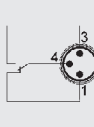

Contact assignment	bottom	top
Float setting		
Minimum	3 - 4	1 - 4
Maximum	1 - 4	3 - 4

NOTICE: In the case of just one reed contact, the switch point is at the top or at the bottom.

2.3.2 **Contact load**
max. 8 W

2.3.3 **Switching voltage**
1-48 V AC/DC

2.3.4 **Switching current**
max. 0.2 A

2.3.5 **Protection class**
IP 65

2.3.6 **Viscosity range**
max. 2000 mm²/s

2.4. ELECTRICAL CHARACTERISTICS TS/TS-L

2.4.1 Electrical function

N/C contact

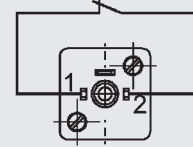

2.4.2 Switching power

2.5 A/50 V - 10,000 switching operations
0.5 A/50 V - 100,000 switching operations

2.4.3 **Minimum switching current**
50 mA

2.4.4 **Switching tolerance**
± 5 K

2.4.5 Switching hysteresis

Normally closed

60 °C - 10-15 K

70 °C - 10-15 K

80 °C - 10-20 K

3. DIMENSIONS

3.1. FLUID LEVEL GAUGE FSA

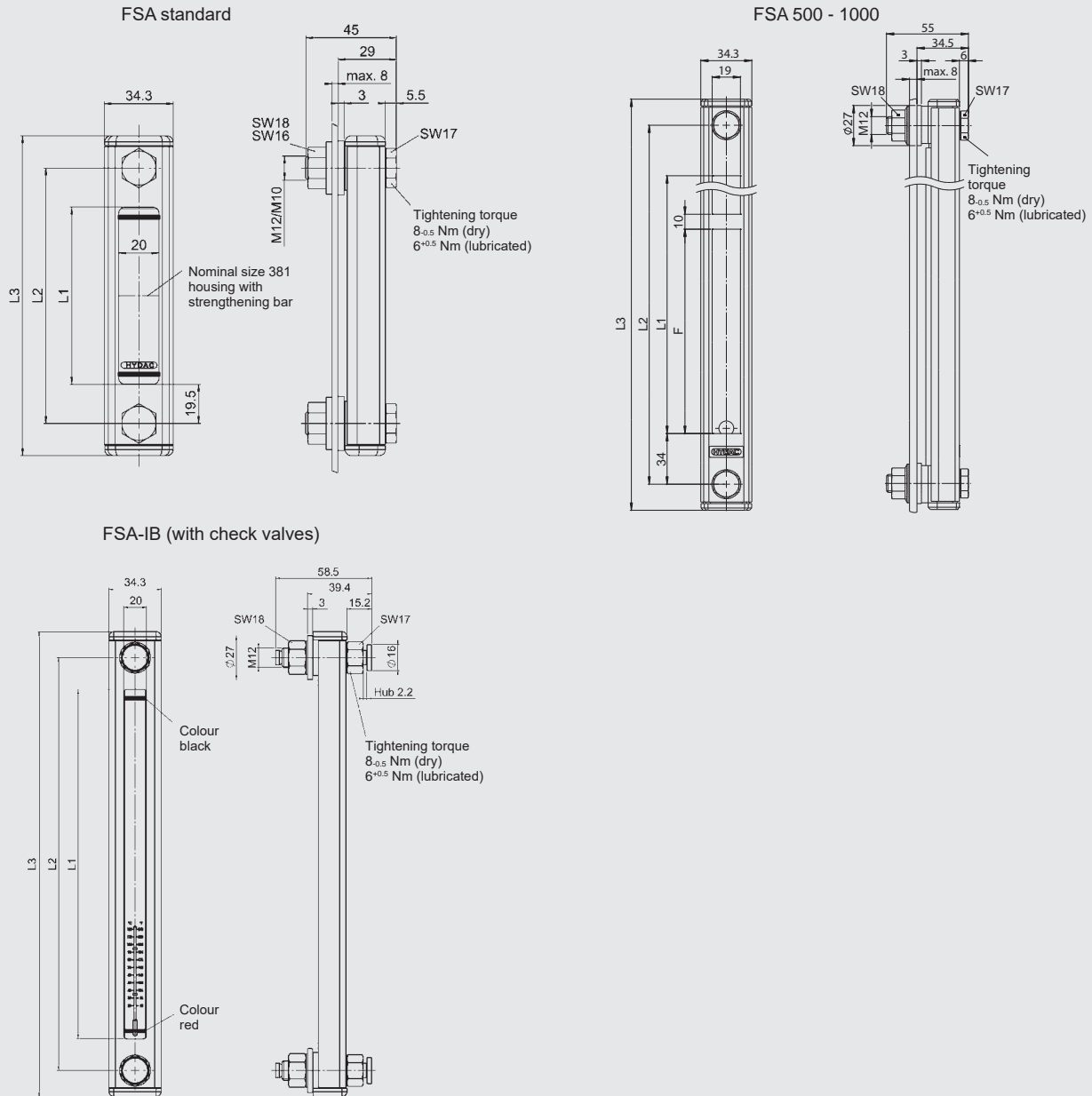

Nominal size \cong Centre distance of bolts	L1 [mm]	L2 [mm]	L3 [mm]	F [mm]	Quantity F
76	37	76	108	-	-
127	88	127	159	-	-
176	137	176	208	-	-
254	215	254	286	-	-
381	342	381	413	-	-
500	432	500	535	137	3
600	532	600	635	170	3
700	632	700	735	150	4
800	732	800	835	175	4
900	832	900	935	158	5
1000	932	1000	1035	147	6

FSAR without mounting nut

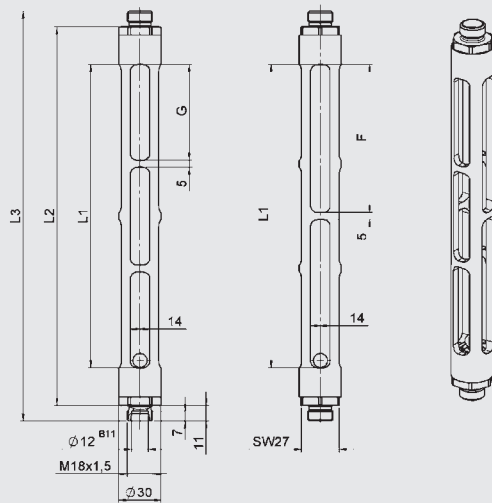

FSAR with mounting nut

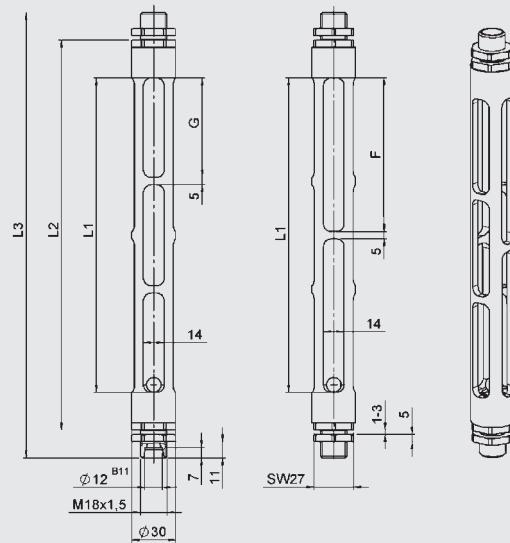

Design	Nominal size \approx Centre distance of bolts	L1 [mm]	L2 [mm]	L3 [mm]	F [mm]	G [mm]
Without nut	FSAR-088	88	141.5	163.5	88	88
	FSAR-137	137	190.5	212.5	137	137
	FSAR-215	215	268.5	290.5	2x 105	3x 68
	FSAR-342	342	395.5	417.5	3x 110.5	4x 82
With nut	FSAR-088	88	139.5	177.5	88	88
	FSAR-137	137	188.5	226.5	137	137
	FSAR-215	215	266.5	304.5	2x 105	3x 68
	FSAR-342	342	393.5	431.5	3x 110.5	4x 82

FSA with temperature switch TS

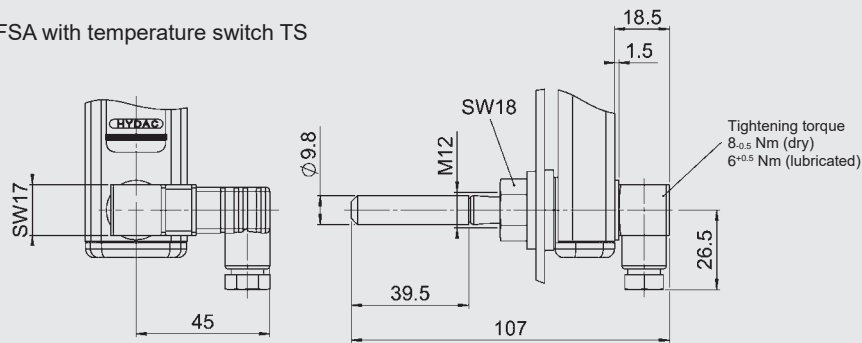

FSA with temperature gauge

FSA / FSK with temperature gauge

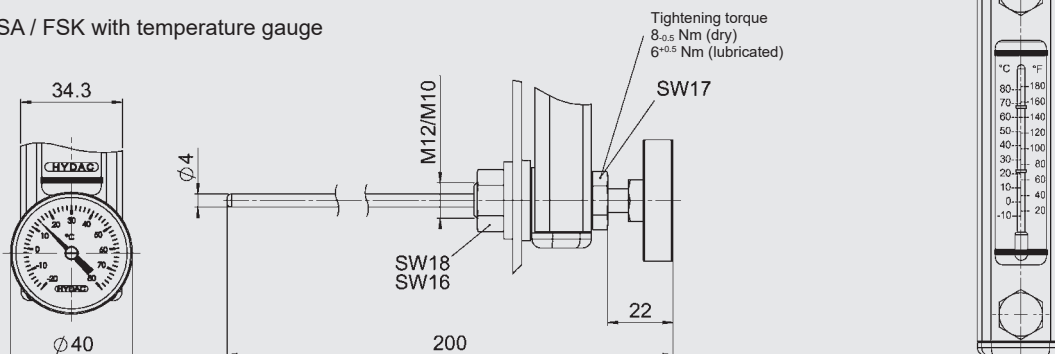

3.2. FLUID LEVEL SENSOR FSK

FSK standard

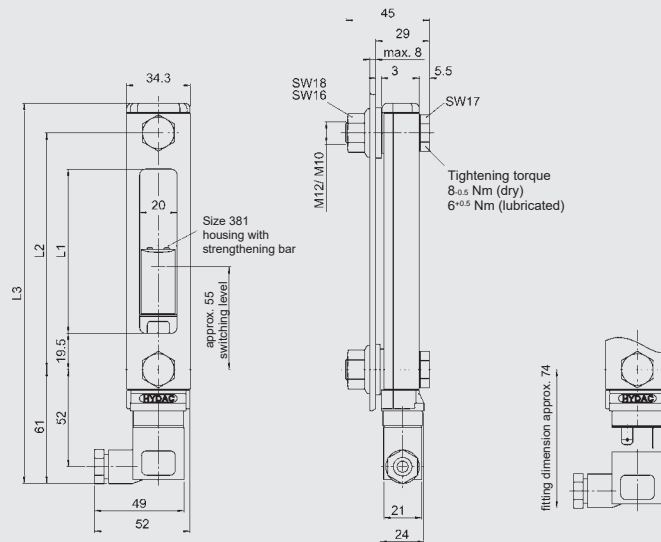

FSK 500 - 1000

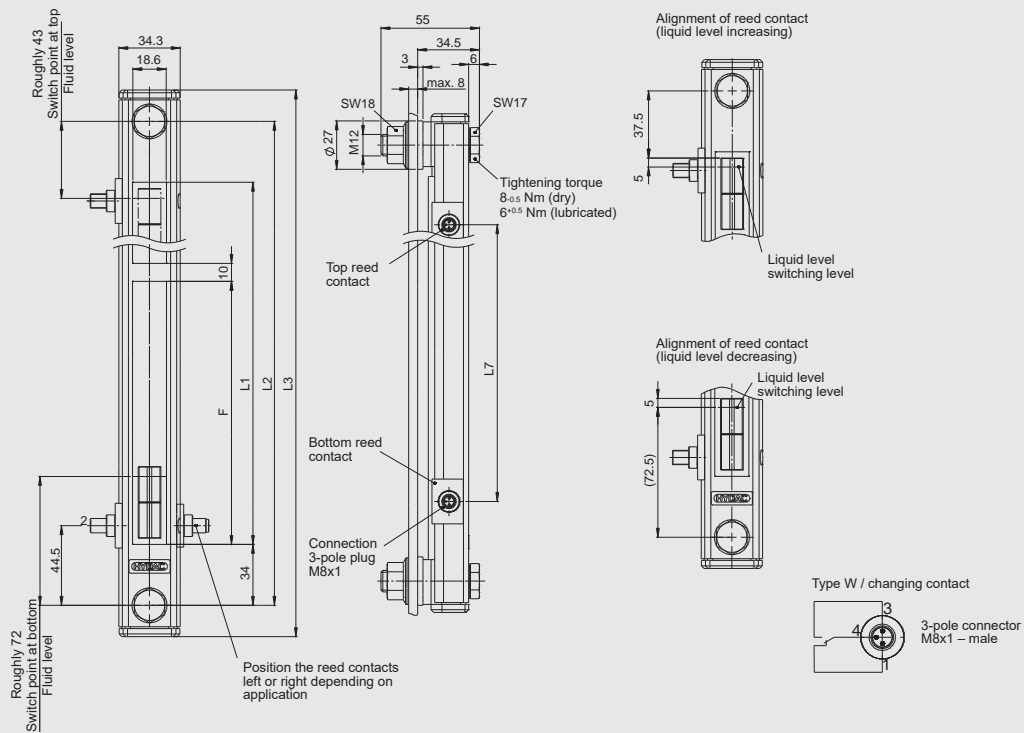

Nominal size ≙ Centre distance of bolts	L1 [mm]	L2 [mm]	L3 [mm]	L7 [mm]	F [mm]	Quantity F
127	88	127	204	203	-	-
176	137	176	253	252	-	-
254	215	254	331	330	-	-
381	342	381	458	457	-	-
500	432	500	535	411	137	3
600	532	600	635	511	170	3
700	632	700	735	611	150	4
800	732	800	835	711	175	4
900	832	900	935	811	158	5
1000	932	1000	1035	911	147	6

EN 5.050.19/10.19

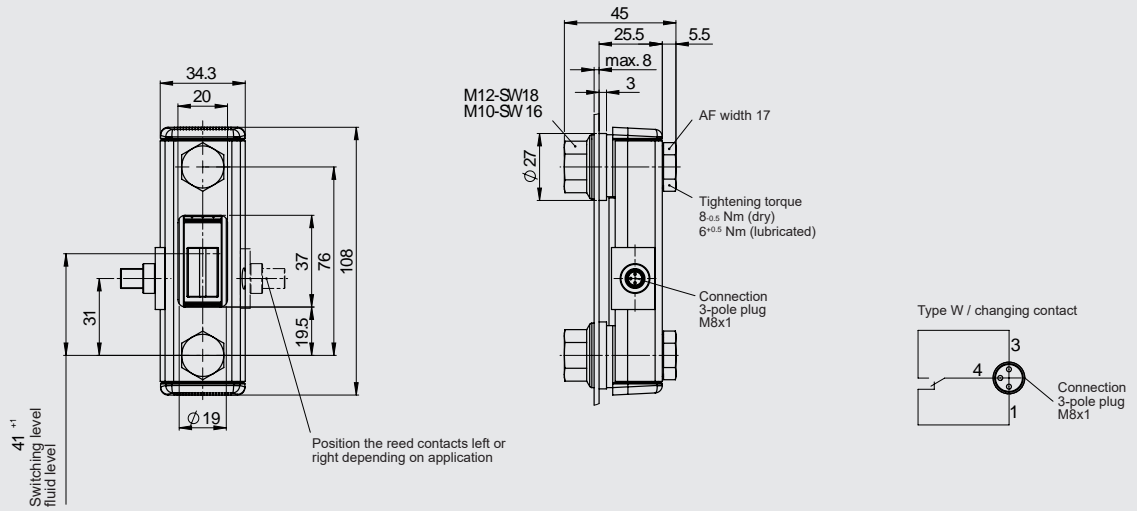
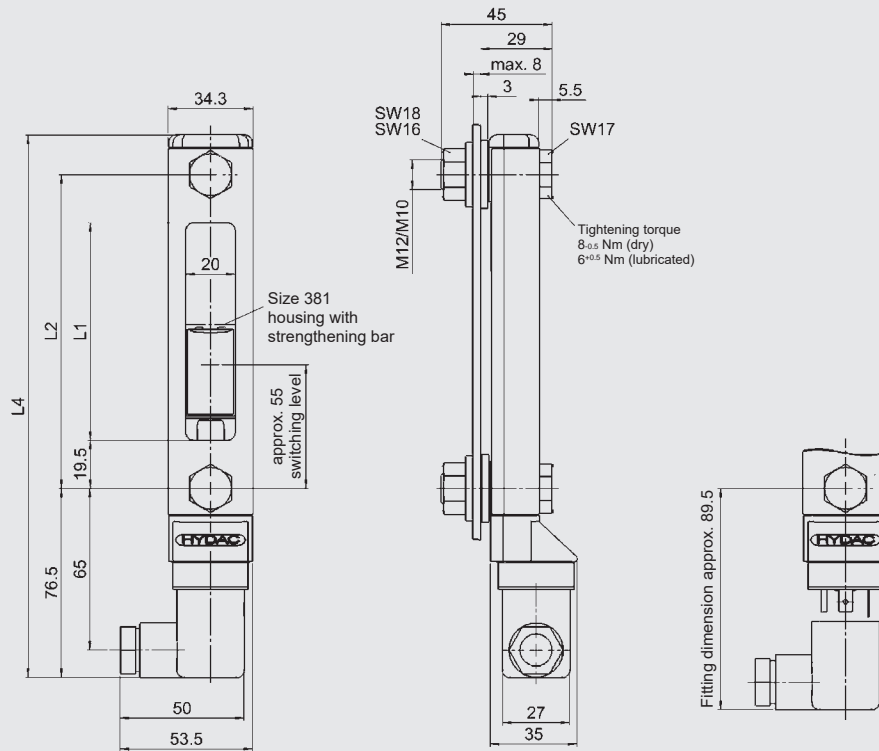
FSK 076

FSK plug Z4

Nominal size ≅	L1 [mm]	L2 [mm]	L3 [mm]
Centre distance of bolts			
127	88	127	219.5
176	137	176	268.5
254	215	254	346.5
381	342	381	473.5

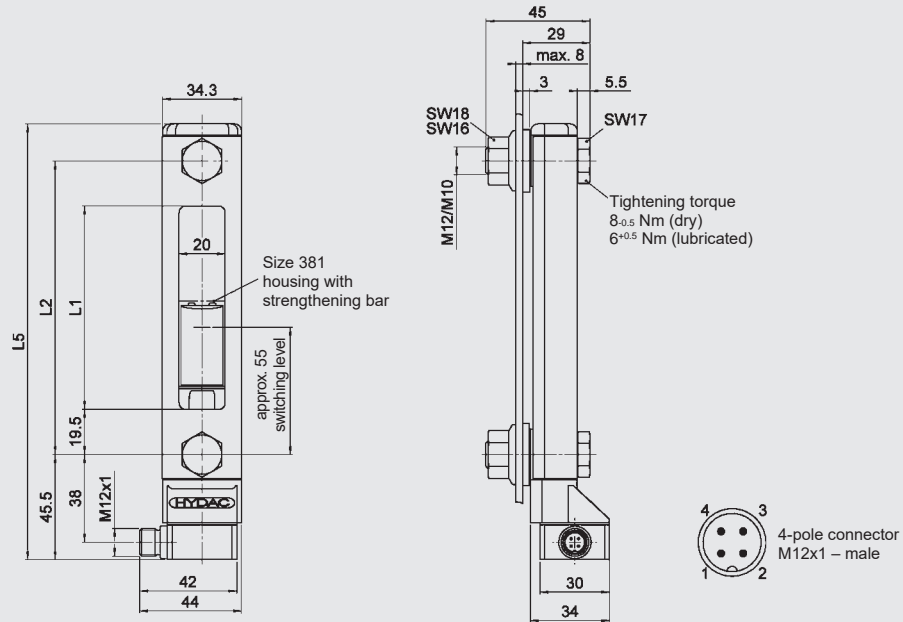
FSK sensor connection SEW-M12x1 horizontal

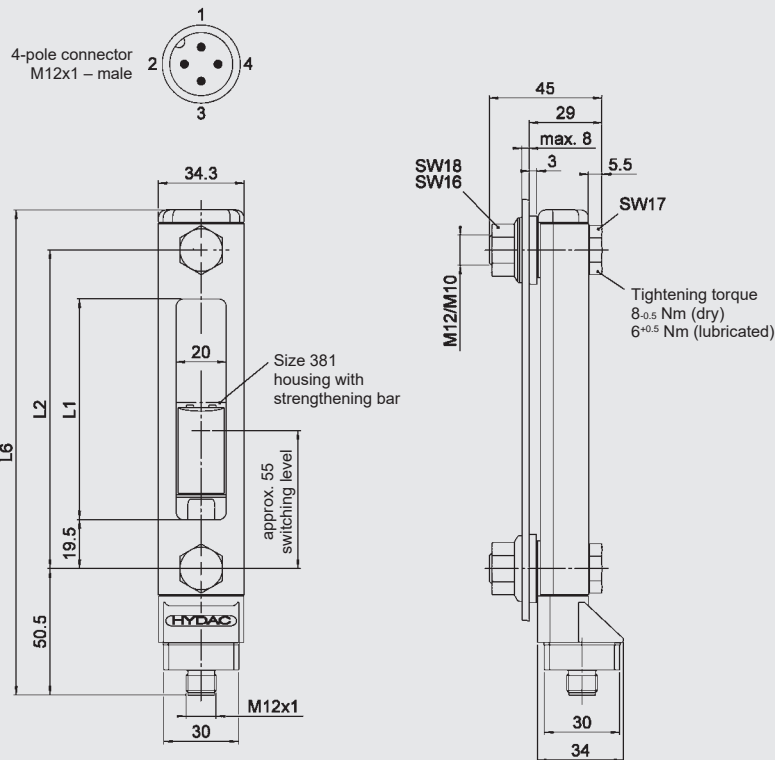

FSK sensor connection SES-M12x1 vertical



Nominal size \cong	L1	L2	L5	L6
Centre distance of bolts	[mm]	[mm]	[mm]	[mm]
127	88	127	188.5	193.5
176	137	176	237.5	242.5
254	215	254	315.5	320.5
381	342	381	442.5	447.5

FSK male connection Form B

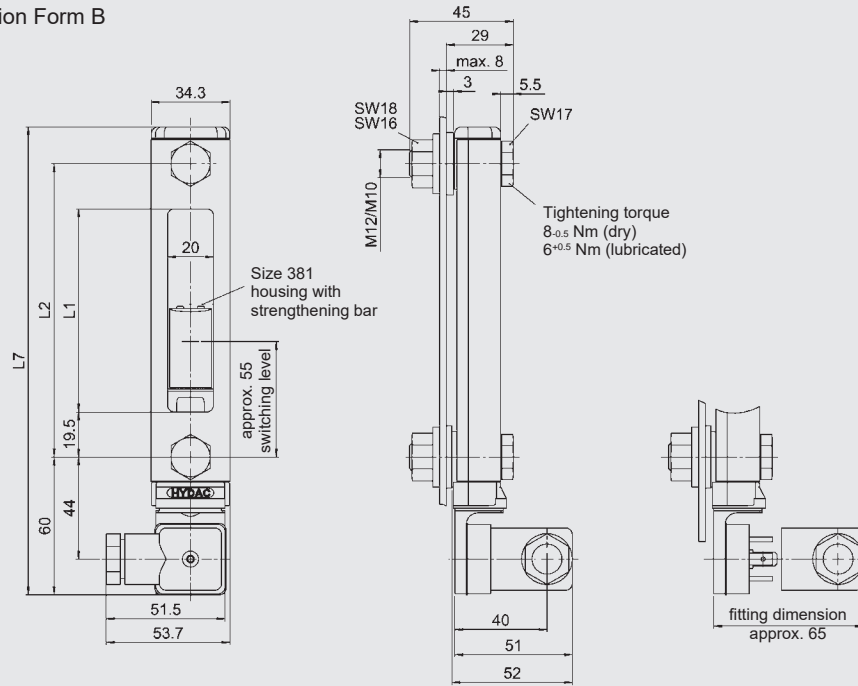

Nominal size \cong Centre distance of bolts	L1 [mm]	L2 [mm]	L7 [mm]
127	88	127	203
176	137	176	252
254	215	254	330
381	342	381	457

FSK with two switch points

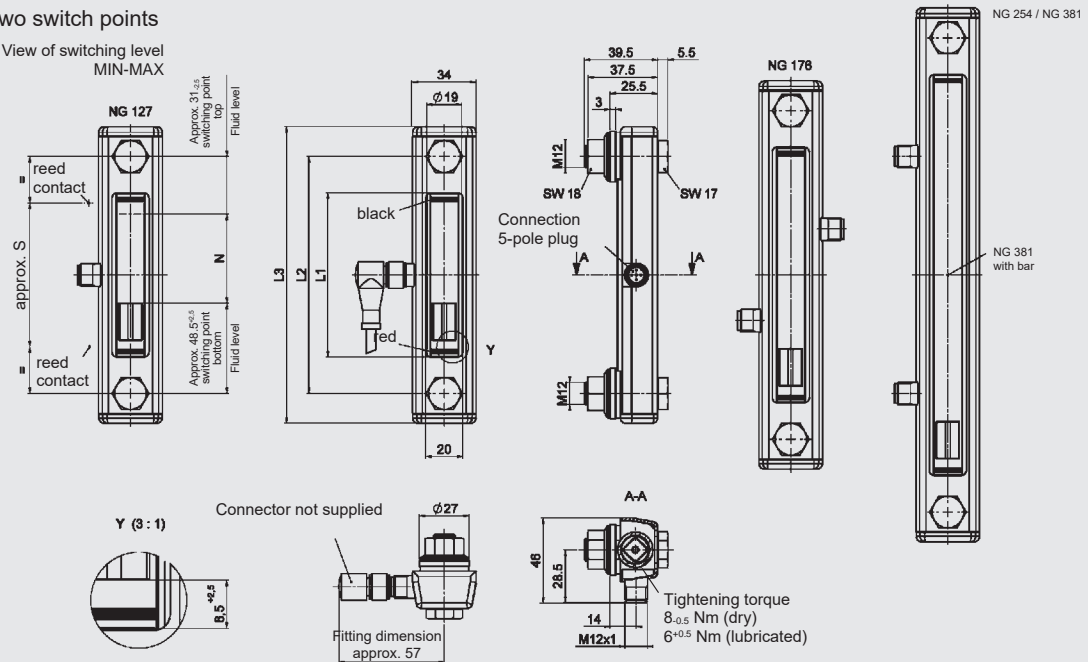
 View of switching level
MIN-MAX

Type	Nominal size \cong Centre distance of bolts	L1 [mm]	L2 [mm]	L3 [mm]	N [mm]	Approx. S [mm]
FSK-127-1.0/WI-/12/2SP	127	88	127	159	47.5	77
FSK-176-1.0/WI-/12/2SP	176	137	176	208	96.5	126
FSK-254-1.0/WI-/12/2SP	254	215	254	286	174.5	204
FSK-381-1.0/WI-/12/2SP	381	342	381	413	301.5	331



FSK with temperature switch TS-L

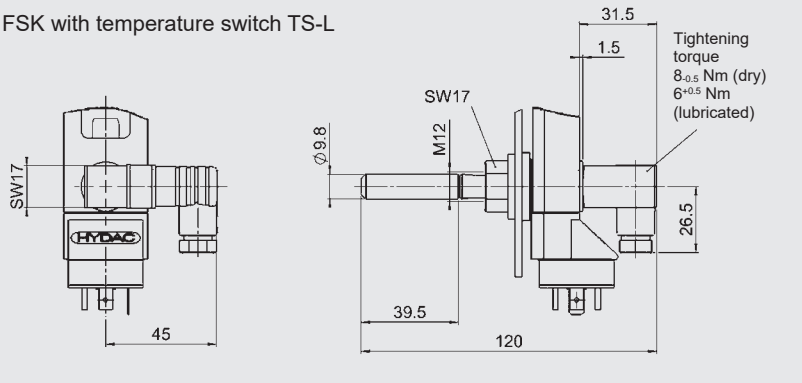

3.3. TEMPERATURE SWITCH TS / TS-L

See FSA with TS fitted
See FSK with TS-L fitted

3.4. ACCESSORIES

Temperature sensor TFP

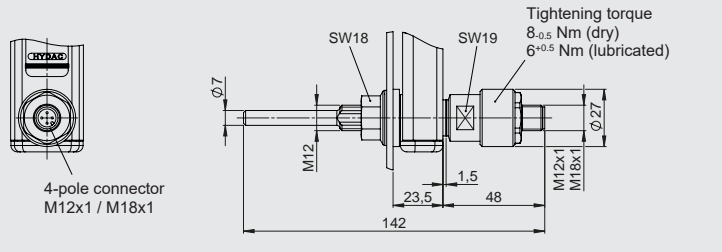

ABK

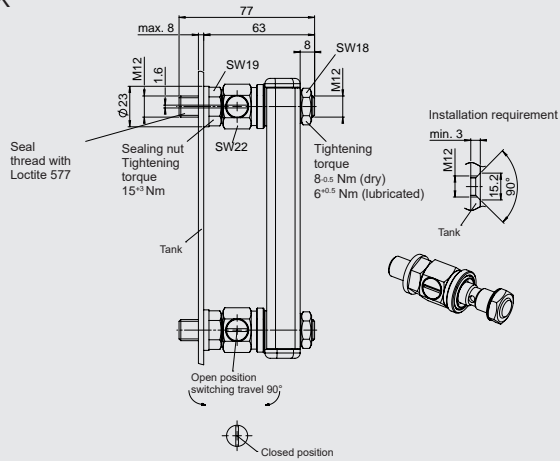

ABV

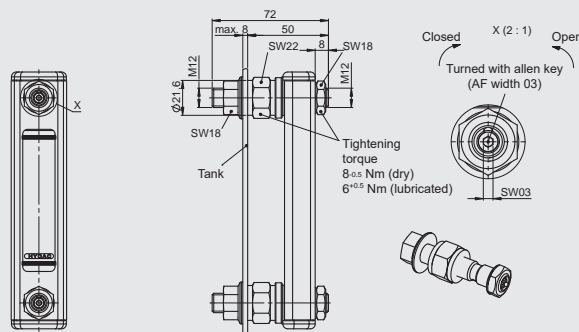

4. SPARE PARTS

4.1. SEAL KIT

Seal kit	Order no.= Part number
FSA - 76 - 381 - 1.X / - /12 NBR	704 616
FSA - 76 - 381 - 2.X / - /12 FKM	704 627
FSA - 76 - 381 - 1.X / - /10 NBR	3248767
FSA - 76 - 381 - 2.X / - /10 FKM	3395614

5. INSTALLATION INFORMATION

5.1. THROUGH-BORE

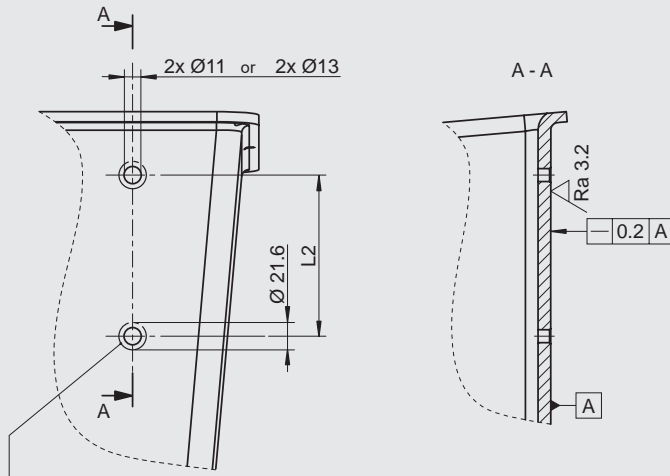

In sealing surface area $\text{Ø } 21.6$ Ra 3.2.
Sealing surface free from contamination,
welding beads, scale, varnish etc.

L2 [mm]
for through-bore
 $\text{Ø } 11$ or $\text{Ø } 13$

076 ± 0.3

127 ± 0.5

176 ± 0.5

254 ± 0.5

381 ± 0.5

500 ± 0.8

600 ± 0.8

700 ± 0.8

800 ± 0.8

900 ± 0.8

1000 ± 0.8

5.2. THREADED HOLE

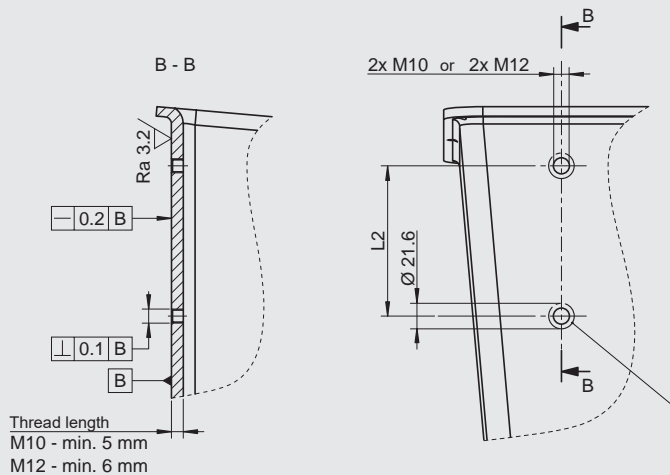

In sealing surface area $\text{Ø } 21.6$ Ra 3.2.
Sealing surface free from contamination,
welding beads, scale, varnish etc.

L2 [mm]
for threaded bore
M10 or M12

076 ± 0.2

127 ± 0.3

176 ± 0.3

254 ± 0.3

381 ± 0.3

500 ± 0.5

600 ± 0.5

700 ± 0.5

800 ± 0.5

900 ± 0.5

1000 ± 0.5



NOTE

The information in this brochure relates to the operating conditions and applications described. For applications and operating conditions not described, please contact the relevant technical department.

The operator is always responsible for determining the product suitability for the specific application. Quantified values for product characteristics are average values for a new product that undergo a time deterioration process.

Subject to technical modifications and errors.

HYDAC Accessories GmbH

Hirschbachstr. 2

66280 Sulzbach/Saar

Tel.: +49 (0)6897 - 509-01

Fax: +49 (0)6897 - 509-1009

Internet: www.hydac.com

E-Mail: accessories@hydac.com

EN 5.050.19/10.19