

MOTORS

Technical Information

OMS Orbital Motor

White is a leading global provider of
motor and steering solutions that power
the evolution of mobile and industrial
applications around the world.

Contents

Chapter 1 Orbital motors	5
Orbital Motors Features.....	6
Orbital Motors Application Areas.....	6
Technical Features.....	6
Speed, torque, and output.....	6
Chapter 2 OMS versions and code numbers	8
OMS with standard 4 hole flange.....	9
<i>OMS Standard motors code numbers</i>	9
OMS with special 4 hole flange.....	9
<i>OMS with special 4 hole flange code numbers</i>	10
OMS with A2 flange.....	10
<i>OMS with A2 flange code numbers</i>	10
OMS with Magneto flange.....	10
<i>OMS with Magneto flange code numbers</i>	11
OMS with SAE B flange.....	11
<i>OMS with SAE B flange code numbers</i>	11
OMS with Wheel (EU).....	11
<i>OMS with Wheel (EU) code numbers</i>	11
OMS with Wheel (US).....	12
<i>OMS with Wheel (US) code numbers</i>	12
OMS with Short flange.....	12
<i>OMS with Short flange code numbers</i>	12
<i>Features</i>	12
Chapter 3 OMS technical data	13
OMS, OMSW, OMSS technical data.....	14
Maximum pressures.....	15
Maximum torque for OMS shaft type.....	15
Maximum permissible shaft seal pressure.....	15
<i>Motor with check valves and without use of drain connection</i>	15
<i>Motor with check valves and with drain connection</i>	16
Pressure drop in motor.....	16
Oil flow in drain line.....	16
Direction of shaft rotation.....	17
Permissible shaft loads.....	17
<i>Shaft load and bearing life time</i>	17
Chapter 4 OMS function diagrams	21

WHITE can accept no responsibility for possible errors in catalogues, brochures, and other printed material. WHITE reserves the right to alter its products without notice. This also applies to products already on order provided that such alterations can be made without subsequent changes being necessary in specifications already agreed.

All trademarks in this material are the property of the respective companies. WHITE and the WHITE logotype are trademarks of WHITE Drive Motors & Steering LLC and WHITE Drive Motors and Steering Sp. z o.o..

All rights reserved.

Archivierung: 11/2025

OMS 80 function diagram.....	22
OMS 100 function diagram.....	22
OMS 125 function diagram.....	23
OMS 160 function diagram.....	23
OMS 200 function diagram.....	24
OMS 250 function diagram.....	24
OMS 315 function diagram.....	25
OMS 400 function diagram.....	25
OMS 500 function diagram.....	26
Chapter 5 Shaft version	27
OMS shaft version	28
OMS port thread versions	31
Chapter 6 OMS dimensions	32
OMS dimensions - European version.....	33
<i>OMS standard flange - European version</i>	33
<i>OMS special flange - European version</i>	35
<i>OMS wheel - European version</i>	36
<i>OMS short - European version</i>	37
OMS dimensions - US version.....	38
<i>OMS standard flange - US version</i>	38
<i>OMS A2 flange - US version</i>	39
<i>OMS magneto flange - US version</i>	41
<i>OMS SAE-B flange - US version</i>	42
<i>OMS Wheel - US version</i>	44
<i>OMS short - US version</i>	45
Chapter 7 OMSS.....	47
Installing the OMSS.....	48
Attached component dimensions	48
Internal spline data for the component to be attached.....	48
<i>Material</i>	48
<i>Hardening specification</i>	48
Motor or attached component drain connection.....	50
Tables.....	51
Figures.....	51

WHITE can accept no responsibility for possible errors in catalogues, brochures, and other printed material. WHITE reserves the right to alter its products without notice. This also applies to products already on order provided that such alterations can be made without subsequent changes being necessary in specifications already agreed.

All trademarks in this material are the property of the respective companies. WHITE and the WHITE logotype are trademarks of WHITE Drive Motors & Steering LLC and WHITE Drive Motors and Steering Sp. z o.o..

All rights reserved.

Archivierung: 11/2025

Chapter 1

Orbital motors

Topics:

- *Orbital Motors Features*
- *Orbital Motors Application Areas*
- *Technical Features*
- *Speed, torque, and output*

WHITE can accept no responsibility for possible errors in catalogues, brochures, and other printed material. WHITE reserves the right to alter its products without notice. This also applies to products already on order provided that such alterations can be made without subsequent changes being necessary in specifications already agreed.

All trademarks in this material are the property of the respective companies. WHITE and the WHITE logotype are trademarks of WHITE Drive Motors & Steering LLC and WHITE Drive Motors and Steering Sp. z o.o..

All rights reserved.

Archivierung: 11/2025

Orbital Motors Features

- Smooth running over the entire speed range
- Constant operating torque over a wide speed range
- High starting torque
- High return pressure without the use of drain line (high pressure shaft seal)
- High efficiency
- High radial and axial bearing capacity
- Long life under extreme operating conditions
- Robust and compact design
- For applications in both open and closed loop hydraulic systems
- Suitable for a wide variety of hydraulics fluids

Orbital Motors Application Areas

The orbital motors are used in the following application areas:

- Construction equipment
- Agricultural equipment
- Material handling & Lifting equipment
- Forestry equipment
- Lawn and turf equipment
- Machine tools and stationary equipment
- Marine equipment
- Special purpose

Technical Features

The program is characterized by technical features appealing to a large number of applications and by motors that can be adapted to a given application.

Adaptions comprise the following variants:

- Motors with:
 - corrosion resistant parts
 - needle bearing (OMP, OMR)
 - needle bearing (OMPW X N, OMR X N)
 - low leakage version or super low leakage version (OMR, OMR X)
 - integrated negative holding brake
 - speed sensor
 - black finish paint
- Short motors without bearings or ultra short motors
- Wheel motors with recessed mounting flange

Speed, torque, and output

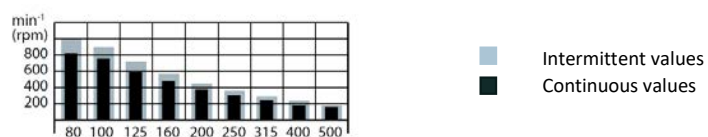

Figure 1 Maximum speed

WHITE can accept no responsibility for possible errors in catalogues, brochures, and other printed material. WHITE reserves the right to alter its products without notice. This also applies to products already on order provided that such alterations can be made without subsequent changes being necessary in specifications already agreed.

All trademarks in this material are the property of the respective companies. WHITE and the WHITE logotype are trademarks of WHITE Drive Motors & Steering LLC and WHITE Drive Motors and Steering Sp. z o.o..

All rights reserved.

Archivierung: 11/2025

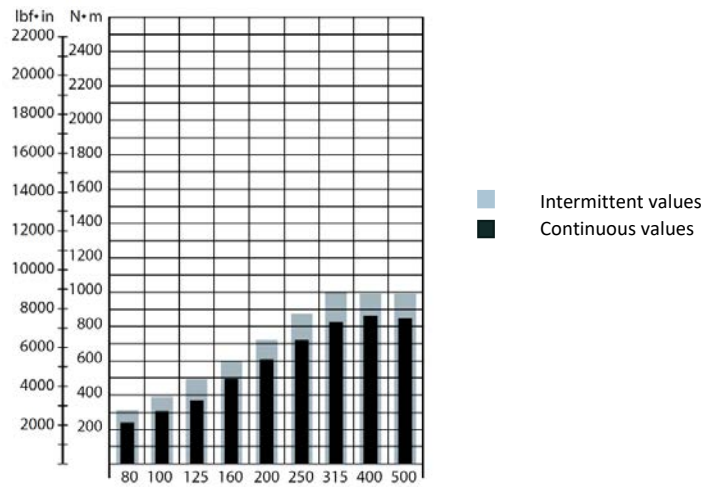

Figure 2 Maximum torque

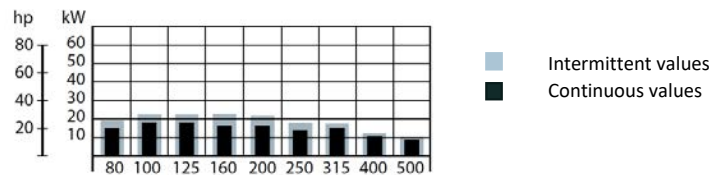

Figure 3 Maximum output

The bar diagrams above are useful for a quick selection of relevant motor size for the application. The final motor size can be determined by using the function diagram for each motor size: see [Chapter 4 OMS function diagrams](#).

The function diagrams are based on actual tests on a representative number of motors from our production. The diagrams apply to a return pressure between 5 and 10 bar [75 and 150 psi] when using mineral based hydraulic oil with a viscosity of 35 mm²/s [165 SUS] and a temperature of 50°C [120°F].

WHITE can accept no responsibility for possible errors in catalogues, brochures, and other printed material. WHITE reserves the right to alter its products without notice. This also applies to products already on order provided that such alterations can be made without subsequent changes being necessary in specifications already agreed.

All trademarks in this material are the property of the respective companies. WHITE and the WHITE logotype are trademarks of WHITE Drive Motors & Steering LLC and WHITE Drive Motors and Steering Sp. z o.o..

All rights reserved.

Chapter 2

OMS versions and code numbers

Topics:

- *OMS with standard 4 hole flange*
- *OMS with special 4 hole flange*
- *OMS with A2 flange*
- *OMS with Magneto flange*
- *OMS with SAE B flange*
- *OMS with Wheel (EU)*
- *OMS with Wheel (US)*
- *OMS with Wheel (US)*
- *OMS with Short flange*

WHITE can accept no responsibility for possible errors in catalogues, brochures, and other printed material. WHITE reserves the right to alter its products without notice. This also applies to products already on order provided that such alterations can be made without subsequent changes being necessary in specifications already agreed.

All trademarks in this material are the property of the respective companies. WHITE and the WHITE logotype are trademarks of WHITE Drive Motors & Steering LLC and WHITE Drive Motors and Steering Sp. z o.o..

All rights reserved.

Archivierung: 11/2025

OMS with standard 4 hole flange

Spigot diameter	Ø82.5mm [3.25 in]						
Bolt circle diameter	Ø106.4 mm [4.20 in]						
Shaft	Main Port size	Drain Port size	Check valve	European version	US version	Main type designation	Conf. code
Cyl. Ø32 mm	G 1/2	G 1/4	Yes	Yes	-	OMS	A1
Cyl. 1.25 in	7/8-14 UNF	7/16-20 UNF	Yes	-	Yes	OMS	A2
Splined 1.25 in	G 1/2	G 1/4	Yes	Yes	-	OMS	A3
Splined 1.25 in	7/8-14 UNF	7/16-20 UNF	Yes	-	Yes	OMS	A4
Tapered 35 mm	G 1/2	G 1/4	Yes	Yes	-	OMS	A5
Tapered 1.25 in	7/8-14 UNF	7/16-20 UNF	Yes	-	Yes	OMS	A6
P.t.o.	G 1/2	G 1/4	Yes	Yes	-	OMS	A7

Table 1 Mounting flange: Standard 4 hole flange

OMS Standard motors code numbers

Conf. code	Displacement								
	80	100	125	160	200	250	315	400	500
A1	151F0500	151F0501	151F0502	151F0503	151F0504	151F0505	151F0506	151F0605	151F0655
A2	151F2200	151F2201	151F2202	151F2203	151F2204	151F2205	151F2206	151F2261	151F2268
A3	151F0507	151F0508	151F0509	151F0510	151F0511	151F0512	151F0513	151F0567	-
A4	151F2207	151F2208	151F2209	151F2210	151F2211	151F2212	151F2213	151F2262	151F2269
A5	151F0514	151F0515	151F0516	151F0517	151F0518	151F0519	151F0520	-	-
A6	151F2214	151F2215	151F2216	151F2217	151F2218	151F2219	151F2220	151F2264	151F2270
A7	151F0560	151F0561	151F0562	151F0563	151F0564	151F0565	151F0566	-	-

Table 2 Code numbers: OMS Standard 4 hole flange

OMS with special 4 hole flange

Spigot diameter	Ø82.5mm [3.25 in]						
Bolt circle diameter	Ø106.4 mm [4.20 in]						
Shaft	Main Port size	Drain Port size	Check valve	European version	US version	Main type designation	Conf. code
Splined 1.25 in	G 1/2	G 1/4	Yes	Yes	-	OMS	B1

Table 3 Mounting flange: Special 4 hole flange

WHITE can accept no responsibility for possible errors in catalogues, brochures, and other printed material. WHITE reserves the right to alter its products without notice. This also applies to products already on order provided that such alterations can be made without subsequent changes being necessary in specifications already agreed.

All trademarks in this material are the property of the respective companies. WHITE and the WHITE logotype are trademarks of WHITE Drive Motors & Steering LLC and WHITE Drive Motors and Steering Sp. z o.o..

All rights reserved.

Archivierung: 11/2025

OMS with special 4 hole flange code numbers

Conf. code	Displacement								
	80	100	125	160	200	250	315	400	500
B1	151F0542	151F0543	151F0544	151F0545	151F0546	151F0547	151F0548	-	-

Table 4 Code numbers: OMS Special 4 hole flange

OMS with A2 flange

Spigot diameter		Ø82.5mm [3.25 in]							
Bolt circle diameter		Ø106.4 mm [4.20 in]							
Shaft	Main Port size	Drain Port size	Check valve	European version	US version	Main type designation	Conf. code		
Cyl. 1 in	7/8-14 UNF	7/16-20 UNF	Yes	-	Yes	OMS	C1		
Cyl. 1.25 in							C2		
Splined 1 in							C3		
Splined 1.25 in							C4		
Tapered 1.25 in							C5		

Table 5 Mounting flange: A2 flange

OMS with A2 flange code numbers

Conf. code	Displacement								
	80	100	125	160	200	250	315	400	500
C1	151F2300	151F2301	151F2302	151F2303	151F2304	151F2305	151F2306	151F2307	151F2345
C2	151F2316	151F2317	151F2318	151F2319	151F2320	151F2321	151F2322	151F2323	151F2347
C3	151F2308	151F2309	151F2310	151F2311	151F2312	151F2313	151F2314	151F2315	151F2346
C4	151F2324	151F2325	151F2326	151F2327	151F2328	151F2329	151F2330	151F2331	151F2348
C5	151F2332	151F2333	151F2334	151F2335	151F2336	151F2337	151F2338	151F2339	151F2349

Table 6 Code numbers: OMS A2 flange

OMS with Magneto flange

Spigot diameter		Ø82.5mm [3.25 in]							
Bolt circle diameter		Ø106.4 mm [4.20 in]							
Shaft	Main Port size	Drain Port size	Check valve	European version	US version	Main type designation	Conf. code		
Cyl. 1 in	7/8-14 UNF	7/16-20 UNF	Yes	-	Yes	OMS	D1		
Cyl. 1.25 in							D2		
Splined 1 in							D3		
Splined 1.25 in							D4		

Table 7 Mounting flange: Magneto flange

WHITE can accept no responsibility for possible errors in catalogues, brochures, and other printed material. WHITE reserves the right to alter its products without notice. This also applies to products already on order provided that such alterations can be made without subsequent changes being necessary in specifications already agreed.

All trademarks in this material are the property of the respective companies. WHITE and the WHITE logotype are trademarks of WHITE Drive Motors & Steering LLC and WHITE Drive Motors and Steering Sp. z o.o..

All rights reserved.

Archivierung: 11/2025

OMS with Magneto flange code numbers

Conf. code	Displacement								
	80	100	125	160	200	250	315	400	500
D1	151F2377	151F2378	151F2379	151F2380	151F2381	151F2382	151F2383	151F2384	151F2385
D2	151F2368	151F2369	151F2370	151F2371	151F2372	151F2373	151F2374	151F2375	151F2376
D3	151F2359	151F2360	151F2361	151F2362	151F2363	151F2364	151F2365	151F2366	151F2367
D4	151F2350	151F2351	151F2352	151F2353	151F2354	151F2355	151F2356	151F2357	151F2358

Table 8 Code numbers: OMS Magneto flange

OMS with SAE B flange

Spigot diameter		Ø101.6 mm [4.00 in]							
Bolt circle diameter		Ø146 mm [5.75 in]							
Shaft	Main Port size	Drain Port size	Check valve	European version	US version	Main type designation	Conf. code		
Splined 0.875 in	7/8-14 UNF	7/16-20 UNF	Yes	-	Yes	OMS	E1		
Splined 1.25 in							E2		

Table 9 Mounting flange: SAE B flange

OMS with SAE B flange code numbers

Conf. code	Displacement								
	80	100	125	160	200	250	315	400	500
E1	151F2413	151F2414	151F2415	151F2416	151F2417	11126590	-	-	-
E2	151F2395	151F2396	151F2397	151F2398	151F2399	151F2400	151F2401	151F2402	151F2403

Table 10 Code numbers: OMS SAE B flange

OMS with Wheel (EU)

Spigot diameter		Ø125 mm [4.92 in]							
Bolt circle diameter		Ø160 mm [6.35 in]							
Shaft	Main Port size	Drain Port size	Check valve	European version	US version	Main type designation	Conf. code		
Cyl. Ø32 mm	G 1/2	G 1/4	Yes	Yes	-	OMSW	F1		
Tapered 35 mm							F2		

Table 11 Mounting flange: Wheel EU

OMS with Wheel (EU) code numbers

Conf. code	Displacement								
	80	100	125	160	200	250	315	400	500
F1	151F0521	151F0522	151F0523	151F0524	151F0525	151F0526	151F0527	151F0610	-
F2	151F0528	151F0529	151F0530	151F0531	151F0532	151F0533	151F0534	151F0609	-

Table 12 Code numbers: Wheel (EU)

WHITE can accept no responsibility for possible errors in catalogues, brochures, and other printed material. WHITE reserves the right to alter its products without notice. This also applies to products already on order provided that such alterations can be made without subsequent changes being necessary in specifications already agreed.

All trademarks in this material are the property of the respective companies. WHITE and the WHITE logotype are trademarks of WHITE Drive Motors & Steering LLC and WHITE Drive Motors and Steering Sp. z o.o..

All rights reserved.

Archivierung: 11/2025

OMS with Wheel (US)

Spigot diameter		Ø127 mm [5.00 in]					
Bolt circle diameter		Ø161.9 mm [6.375 in]					
Shaft	Main Port size	Drain Port size	Check valve	European version	US version	Main type designation	Conf. code
Cyl. 1.25 in	7/8-14 UNF	7/16-20 UNF	Yes	-	Yes	OMSW	G1
Tapered 1.25 in							G2

Table 13 Mounting flange: Wheel US

OMS with Wheel (US) code numbers

Conf. code	Displacement								
	80	100	125	160	200	250	315	400	500
G1	151F2235	151F2236	151F2237	151F2238	151F2239	151F2240	151F2241	151F2265	151F2266
G2	151F2242	151F2243	151F2244	151F2245	151F2246	151F2247	151F2248	151F2263	151F2267

Table 14 Code numbers: Wheel (US)

OMS with Short flange

Spigot diameter		Ø100 mm [3.94 in]					
Bolt circle diameter		Ø125 mm [4.92 in]					
Shaft	Main Port size	Drain Port size	Check valve	European version	US version	Main type designation	Conf. code
No output shaft	G 1/2	G 1/4	Yes	Yes	-	OMSS	H1
	7/8-14 UNF	7/16-20 UNF	Yes	-	Yes	OMSS	H2

Table 15 Mounting flange: Short

OMS with Short flange code numbers

Conf. code	Displacement								
	80	100	125	160	200	250	315	400	500
H1	151F0535	151F0536	151F0537	151F0538	151F0539	151F0540	151F0541	151F0608	-
H2	151F2249	151F2250	151F2251	151F2252	151F2253	151F2254	151F2255	151F2256	151F2257

Table 16 Code numbers: Short

Features

Features available (options):

- Speed sensor
- Motor with tachometer connection
- High pressure shaft seal
- Viton shaft seal
- Painted
- Ultra short

WHITE can accept no responsibility for possible errors in catalogues, brochures, and other printed material. WHITE reserves the right to alter its products without notice. This also applies to products already on order provided that such alterations can be made without subsequent changes being necessary in specifications already agreed.

All trademarks in this material are the property of the respective companies. WHITE and the WHITE logotype are trademarks of WHITE Drive Motors & Steering LLC and WHITE Drive Motors and Steering Sp. z o.o..

All rights reserved.

Archivierung: 11/2025

Chapter 3

OMS technical data

Topics:

- *OMS, OMSW, OMSS technical data*
- *Maximum permissible shaft seal pressure*
- *Pressure drop in motor*
- *Oil flow in drain line*
- *Direction of shaft rotation*
- *Permissible shaft loads*

WHITE can accept no responsibility for possible errors in catalogues, brochures, and other printed material. WHITE reserves the right to alter its products without notice. This also applies to products already on order provided that such alterations can be made without subsequent changes being necessary in specifications already agreed.

All trademarks in this material are the property of the respective companies. WHITE and the WHITE logotype are trademarks of WHITE Drive Motors & Steering LLC and WHITE Drive Motors and Steering Sp. z o.o..

All rights reserved.

Archivierung: 11/2025

OMS, OMSW, OMSS technical data

Type			OMS OMSW OMSS								
			80	100	125	160	200	250	315	400	500
Motor size											
Geometric displacement	cm ³		80.5	100.0	125.7	159.7	200.0	250.0	314.9	393.0	488.0
	[in ³]		[4.91]	[6.10]	[7.67]	[9.75]	[12.20]	[15.26]	[19.22]	[23.98]	[29.78]
Maximum speed	min ⁻¹	cont.	810	750	600	470	375	300	240	190	155
	[rpm]	int. ¹⁾	1000	900	720	560	450	360	285	230	185
Maximum torque	N•m [lbf•in]	cont.	240	305	375	490	610	720	825	865	850
			[2120]	[2700]	[3320]	[4340]	[5400]	[6370]	[7300]	[7660]	[7520]
		int. ¹⁾	310	390	490	600	720	870	1000	990	990
			[2740]	[3450]	[4340]	[5310]	[6370]	[7700]	[8850]	[8760]	[8760]
Maximum output	kW [hp]	cont.	15.5	18.0	18.0	16.5	16.5	14.5	15.0	11.0	9.0
			[20.8]	[24.1]	[24.1]	[22.1]	[22.1]	[19.4]	[20.1]	[14.8]	[12.1]
		int. ¹⁾	19.5	22.5	22.5	23.0	22.0	18.0	17.0	12.5	10.5
			[26.2]	[30.2]	[30.2]	[30.8]	[29.5]	[24.1]	[22.8]	[16.8]	[14.1]
Maximum pressure drop.	bar [psi]	cont.	210	210	210	210	210	200	200	160	120
			[3050]	[3050]	[3050]	[3050]	[3050]	[2900]	[2900]	[2320]	[1740]
		int. ¹⁾	275	275	275	260	250	250	240	190	140
			[3990]	[3990]	[3990]	[3770]	[3630]	[3630]	[3480]	[2760]	[2030]
peak ²⁾	295	295	295	280	270	270	260	210	160		
	[4280]	[4280]	[4280]	[4060]	[3920]	[3920]	[3770]	[3050]	[2320]		
Maximum oil flow	l/min [US gal/ min]	cont.	65	75	75	75	75	75	75	75	75
			[17.2]	[19.8]	[19.8]	[19.8]	[19.8]	[19.8]	[19.8]	[19.8]	[19.8]
		int. ¹⁾	80	90	90	90	90	90	90	90	90
			[21.1]	[23.8]	[23.8]	[23.8]	[23.8]	[23.8]	[23.8]	[23.8]	
Maximum starting pressure with unloaded shaft	bar [psi]		12	10	10	8	8	8	8	8	8
			[175]	[145]	[145]	[115]	[115]	[115]	[115]	[115]	[115]
Minimum starting torque	at max. press. drop cont. N•m [lbf•in]		180	230	290	370	470	560	710	710	660
			[1590]	[2040]	[2570]	[3270]	[4160]	[4960]	[6280]	[6280]	[5840]
		at max. press. drop int. ¹⁾ N•m [lbf•in]	235	300	380	460	560	700	850	840	770
	[2080]		[2660]	[3360]	[4070]	[4960]	[6200]	[7520]	[7430]	[6820]	

Table 17 OMS, OMSW, OMSS technical data

- 1) Intermittent operation: the permissible values may occur for max. 10% of every minute.
 2) Peak load: the permissible values may occur for max. 1% of every minute.

Note:

For max. permissible combination of flow and pressure, see function diagram for actual motor.

Maximum pressures

Type			Maximum inlet pressure	Maximum return pressure with drain line
OMS OMSW OMSS	bar [psi]	cont.	230 [3340]	140 [2030]
		int.	295 [4280]	175 [2540]
		peak	300 [4350]	210 [3050]

Table 18 Maximum pressures

Maximum torque for OMS shaft type

			Splined 1 in	Cyl. 1 in	Splined 0.875 in
Max torque for shaft type	Nm [lbf•in]	cont.	360 [3190]	300 [2660]	200 [1770]
		int.	450 [3980]	410 [3630]	200 [1770]

Table 19 Maximum torque for OMS shaft type

Maximum permissible shaft seal pressure

Motor with check valves and without use of drain connection

The pressure on the shaft seal never exceeds the pressure in the return line.

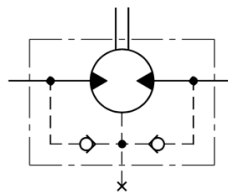
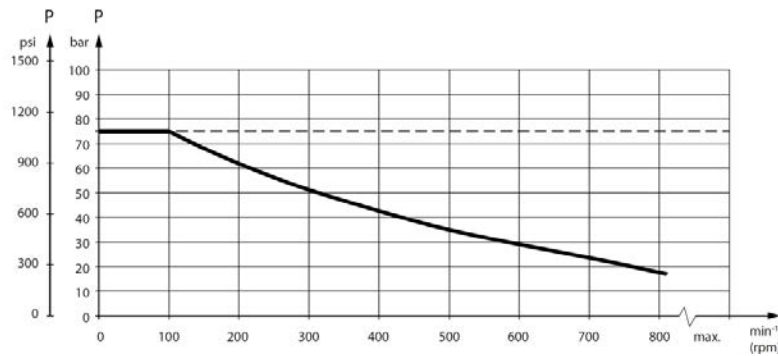

Figure 4 OMS with check valves without drain connection

Motor with check valves and with drain connection

The shaft seal pressure equals the pressure on the drain line.



--- Intermittent operation: the permissible values may occur for max. 10% of every minute.
 — Continuous operation

Figure 5 Maximum return pressure without drain line or maximum pressure in the drain line

Pressure drop in motor

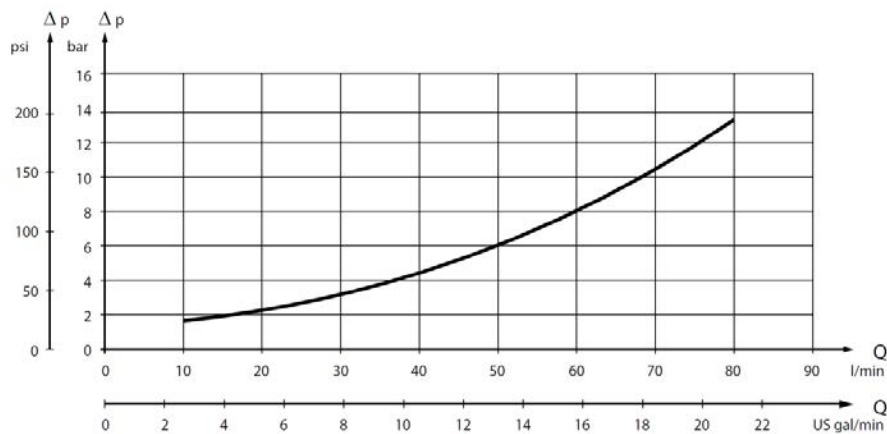

Figure 6 Pressure Drop in OMSW

The curve applies to an unloaded motor shaft and an oil viscosity of 35 mm²/s [165 SUS]

Oil flow in drain line

The table below shows the max. oil flow in the drain line at a return pressure less than 5-10 bar [75-150 psi]. Pressure Viscosity Oil flow in drop drain line bar mm²/s l/min [psi] [SUS] [US gal/min]

Pressure drop bar [psi]	Viscosity mm ² /s [SUS]	Oil flow in drain line l/min [US gal/min]
140 [2030]	20 [100]	1.5 [0.40]
	35 [165]	1.0 [0.26]
210 [3050]	20 [100]	3.0 [0.79]
	35 [165]	2.0 [0.53]

Table 20 Oil flow in drain line

WHITE can accept no responsibility for possible errors in catalogues, brochures, and other printed material. WHITE reserves the right to alter its products without notice. This also applies to products already on order provided that such alterations can be made without subsequent changes being necessary in specifications already agreed.

All trademarks in this material are the property of the respective companies. WHITE and the WHITE logotype are trademarks of WHITE Drive Motors & Steering LLC and WHITE Drive Motors and Steering Sp. z o.o..

All rights reserved.

Archivierung: 11/2025

Direction of shaft rotation

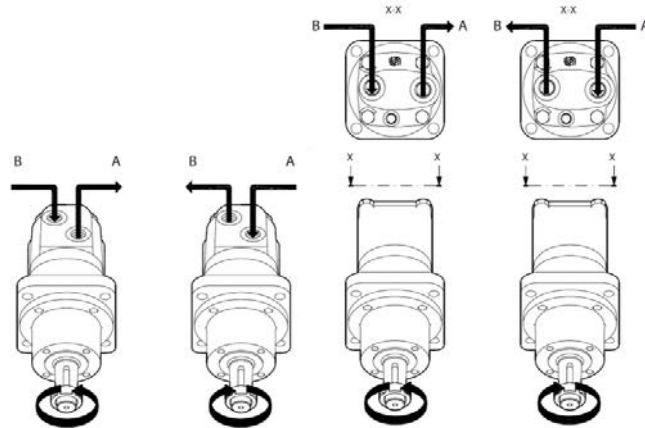

Figure 7 direction of shaft rotation

Permissible shaft loads

Shaft load and bearing life time

The output shaft runs in tapered roller bearings that permit high axial and radial forces.

The permissible radial load on the shaft is shown for an axial load of 0 N as a function of the distance from the mounting flange to the point of load application.

The curve is based on B10 bearing life (2000 hours or 12,000,000 shaft revolutions at 100 min^{-1}) at rated output torque, when mineral-based hydraulic oil with a sufficient content of anti-wear additives, is used.

For 3,000,000 shaft revolutions or 500 hours – increase these shaft loads with 52%.

The dash curve shows maximum radial shaft load. Any shaft load exceeding the values shown in the curve will involve a risk of breakage.

Bearing life calculations can be made using the explanation and formula provided in the chapter *Bearing dimensioning* in the technical information *General Orbital Motors*.

OMS mounting flange: Standard – A2 – Magneto – SAE B

Shaft:

- Cyl. 32 mm
- Cyl. 1.25 in
- Splined 1.25 in.
- Tapered 35 mm
- Tapered 1.25 in
- P.t.o.

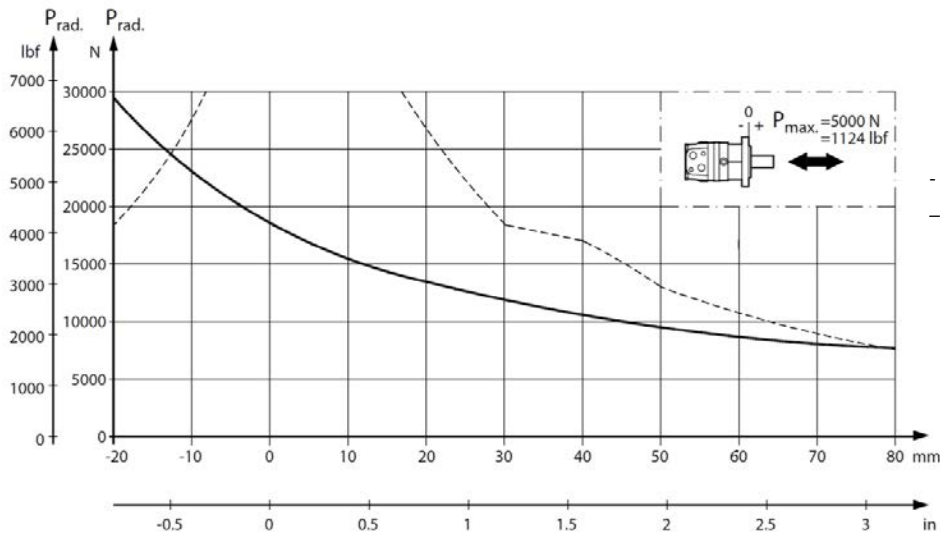

Figure 8 OMS Mounting flange: Standard, A2, Magneto, SAE B

OMS mounting flange: Wheel

Shaft:

- All shaft types

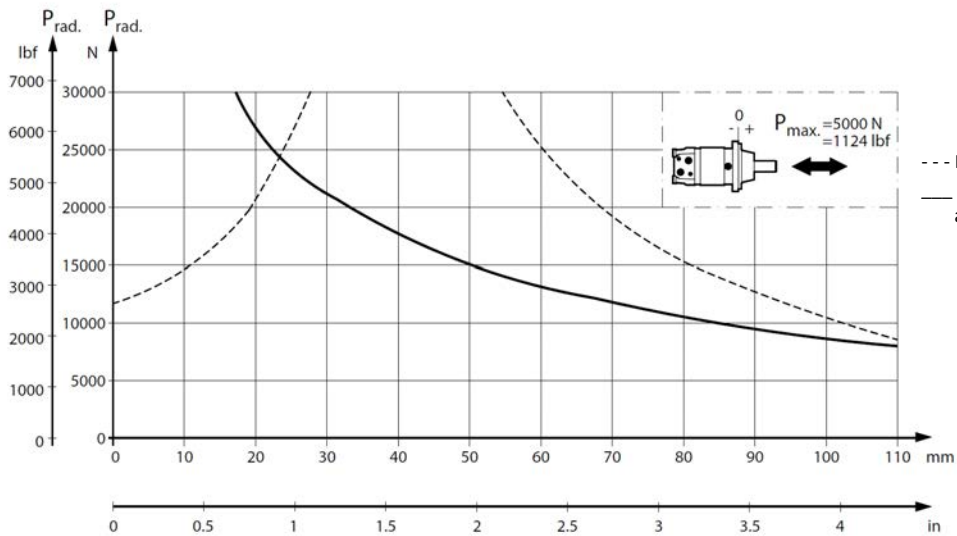

Figure 9 OMS Mounting flange: Wheel

WHITE can accept no responsibility for possible errors in catalogues, brochures, and other printed material. WHITE reserves the right to alter its products without notice. This also applies to products already on order provided that such alterations can be made without subsequent changes being necessary in specifications already agreed.

All trademarks in this material are the property of the respective companies. WHITE and the WHITE logotype are trademarks of WHITE Drive Motors & Steering LLC and WHITE Drive Motors and Steering Sp. z o.o..

All rights reserved.

Archivierung: 11/2025

OMS mounting flange: Special

Shaft:

- Splined 1.25 in

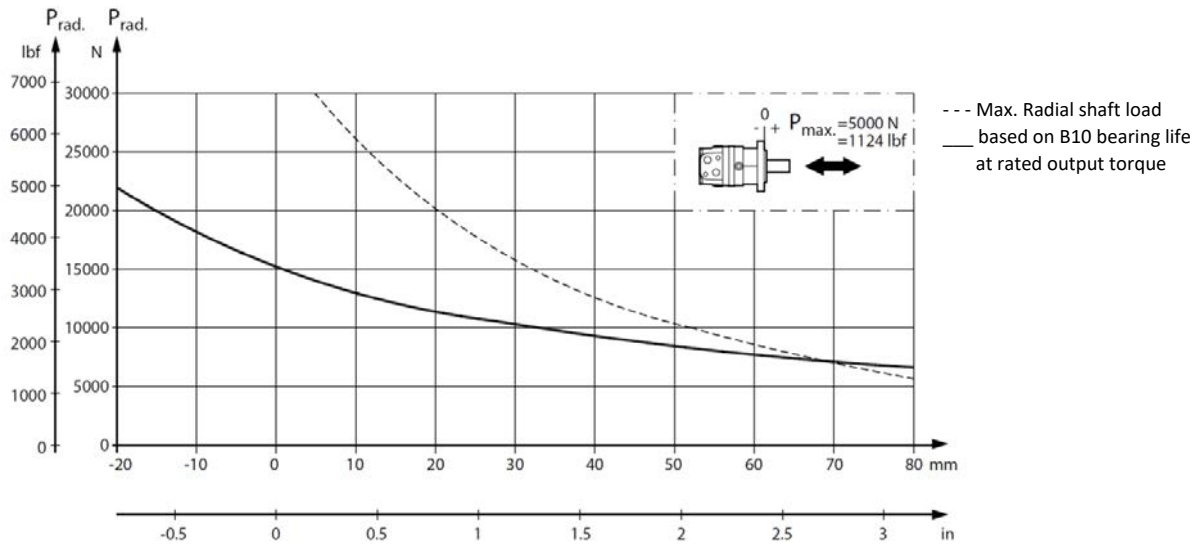

Figure 10 OMS Mounting flange: special

OMS mounting flange: A2 – Magneto

Shaft:

- A2 – Magneto
- Cyl. 1 in – Splined 1 in

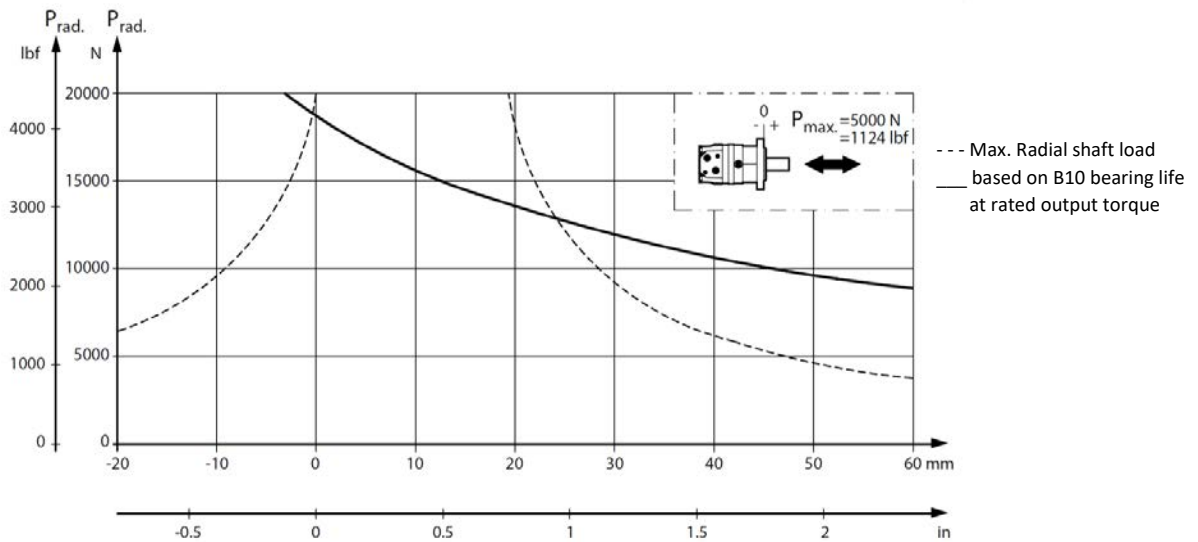

Figure 11 Mounting flange: A2-Magneto

WHITE can accept no responsibility for possible errors in catalogues, brochures, and other printed material. WHITE reserves the right to alter its products without notice. This also applies to products already on order provided that such alterations can be made without subsequent changes being necessary in specifications already agreed.

All trademarks in this material are the property of the respective companies. WHITE and the WHITE logotype are trademarks of WHITE Drive Motors & Steering LLC and WHITE Drive Motors and Steering Sp. z o.o.

All rights reserved.

Archivierung: 11/2025

OMS mounting flange: SAE B

Shaft:

- Splined 0.875 in

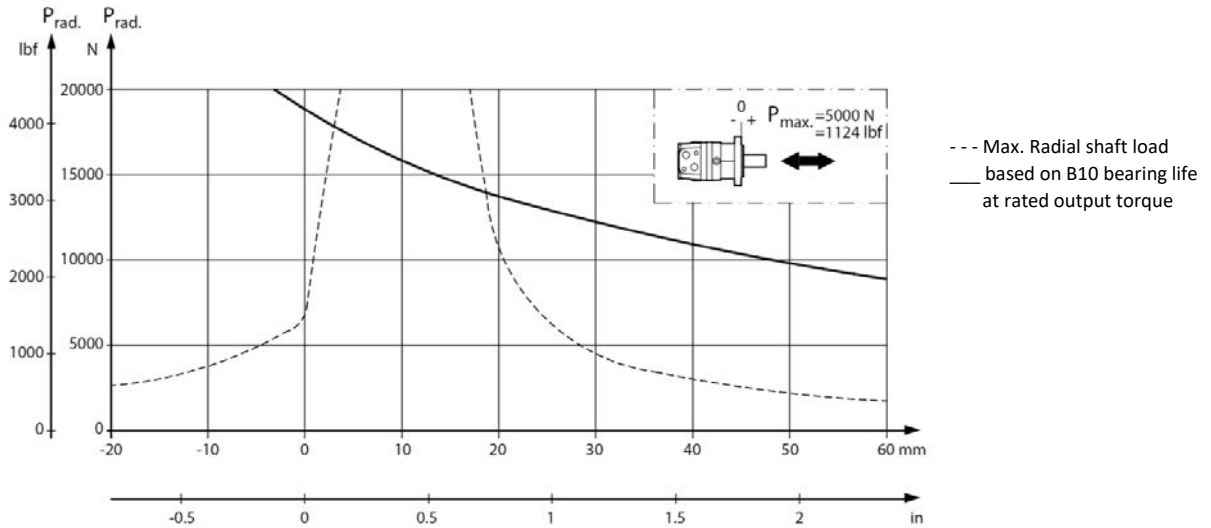

Figure 12 Mounting flange: SAE B

WHITE can accept no responsibility for possible errors in catalogues, brochures, and other printed material. WHITE reserves the right to alter its products without notice. This also applies to products already on order provided that such alterations can be made without subsequent changes being necessary in specifications already agreed.

All trademarks in this material are the property of the respective companies. WHITE and the WHITE logotype are trademarks of WHITE Drive Motors & Steering LLC and WHITE Drive Motors and Steering Sp. z o.o..

All rights reserved.

Archivierung: 11/2025

Chapter 4

OMS function diagrams

Topics:

- *OMS 80 function diagram*
- *OMS 100 function diagram*
- *OMS 125 function diagram*
- *OMS 160 function diagram*
- *OMS 200 function diagram*
- *OMS 250 function diagram*
- *OMS 315 function diagram*
- *OMS 400 function diagram*
- *OMS 500 function diagram*

WHITE can accept no responsibility for possible errors in catalogues, brochures, and other printed material. WHITE reserves the right to alter its products without notice. This also applies to products already on order provided that such alterations can be made without subsequent changes being necessary in specifications already agreed.

All trademarks in this material are the property of the respective companies. WHITE and the WHITE logotype are trademarks of WHITE Drive Motors & Steering LLC and WHITE Drive Motors and Steering Sp. z o.o..

All rights reserved.

Archivierung: 11/2025

OMS 80 function diagram

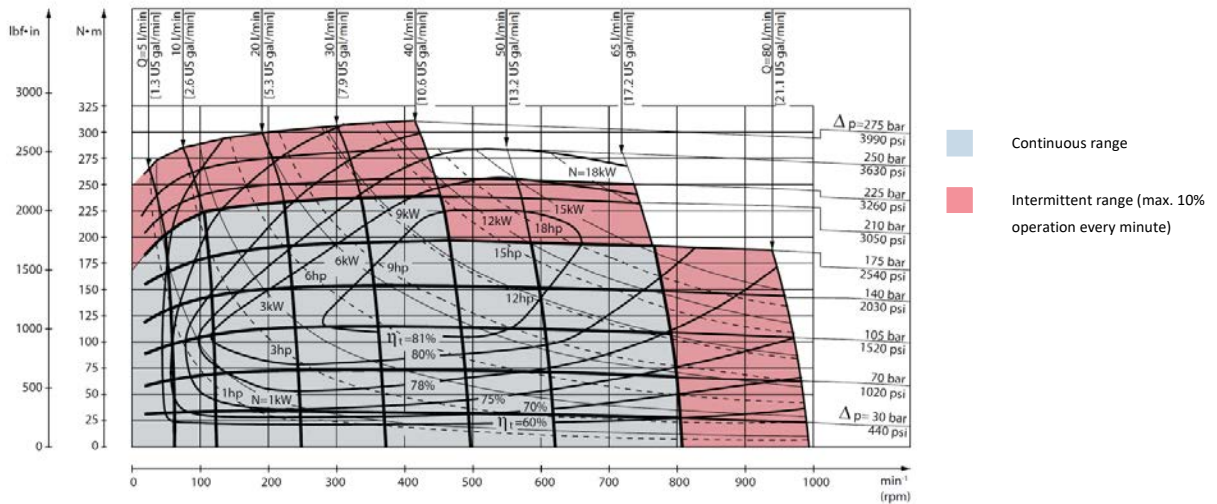

Figure 13 OMS 80 function diagram

OMS 100 function diagram

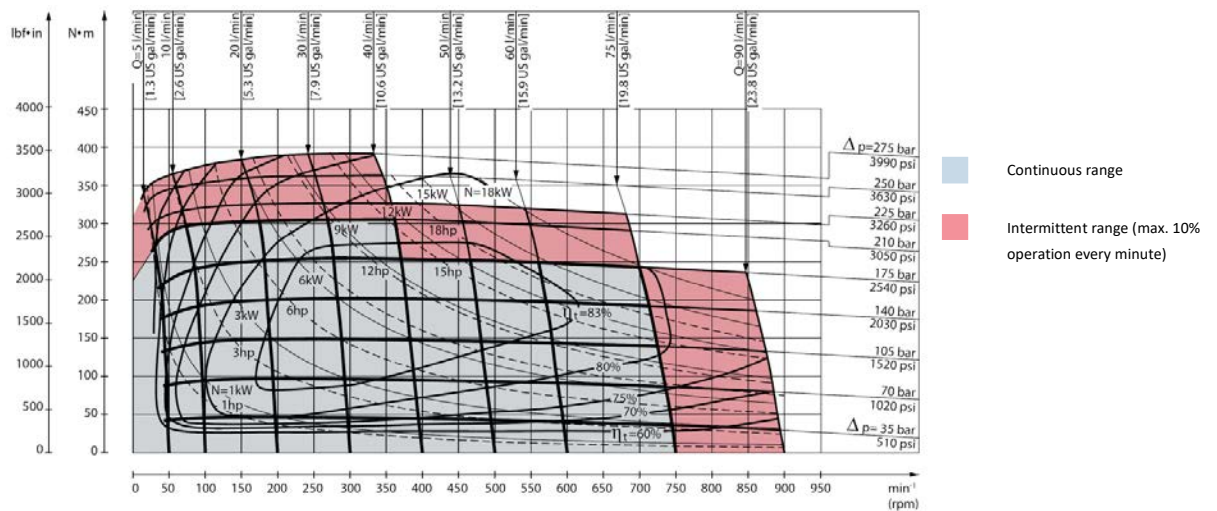

Figure 14 OMS 100 function diagram

WHITE can accept no responsibility for possible errors in catalogues, brochures, and other printed material. WHITE reserves the right to alter its products without notice. This also applies to products already on order provided that such alterations can be made without subsequent changes being necessary in specifications already agreed.

All trademarks in this material are the property of the respective companies. WHITE and the WHITE logotype are trademarks of WHITE Drive Motors & Steering LLC and WHITE Drive Motors and Steering Sp. z o.o..

All rights reserved.

Archivierung: 11/2025

OMS 125 function diagram

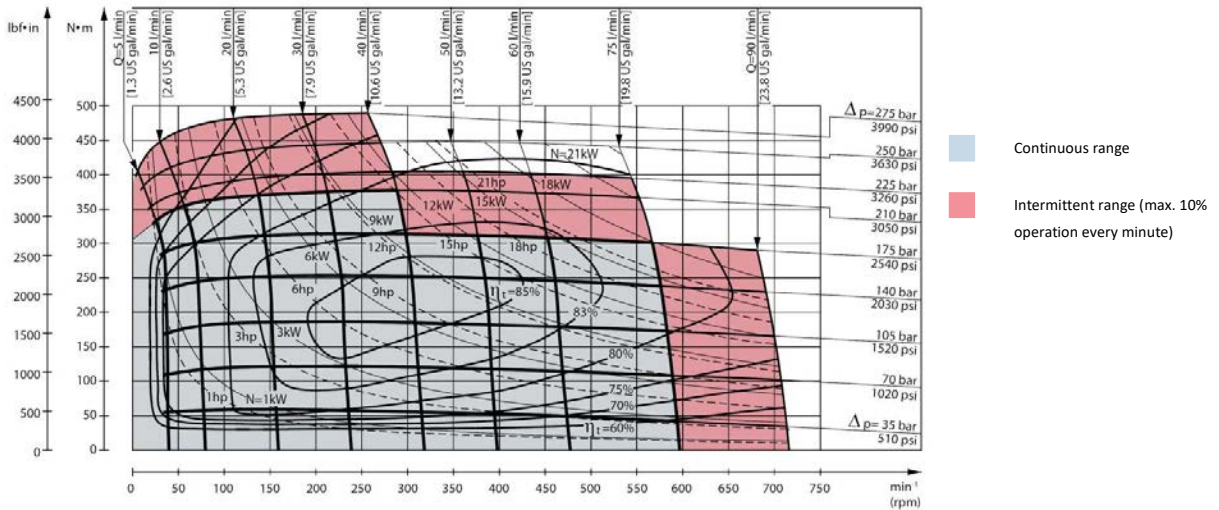

Figure 15 OMS 125 function diagram

OMS 160 function diagram

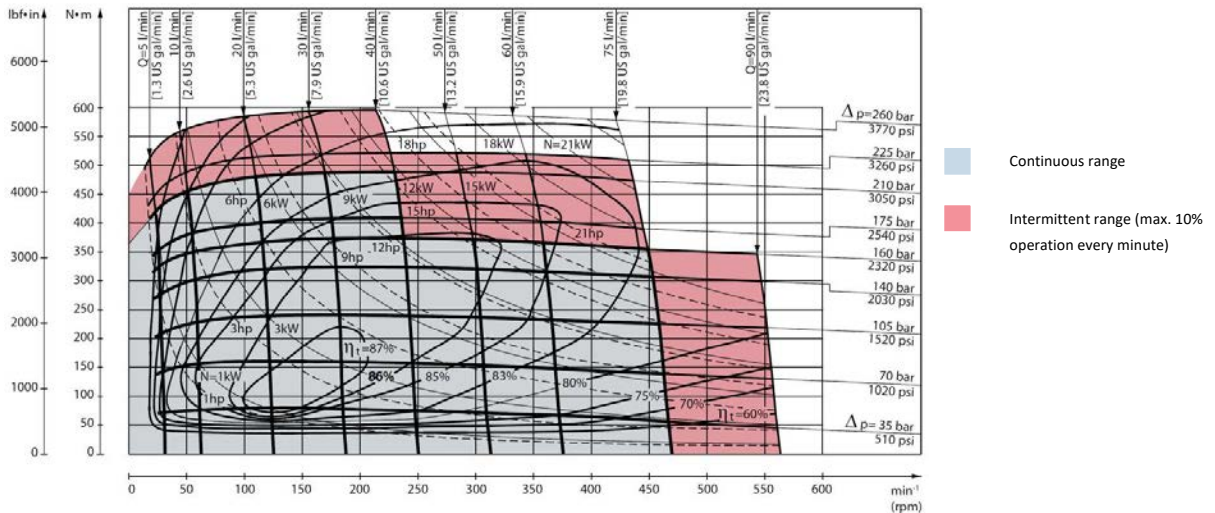

Figure 16 OMS 160 function diagram

WHITE can accept no responsibility for possible errors in catalogues, brochures, and other printed material. WHITE reserves the right to alter its products without notice. This also applies to products already on order provided that such alterations can be made without subsequent changes being necessary in specifications already agreed.

All trademarks in this material are the property of the respective companies. WHITE and the WHITE logotype are trademarks of WHITE Drive Motors & Steering LLC and WHITE Drive Motors and Steering Sp. z o.o..

All rights reserved.

Archivierung: 11/2025

OMS 200 function diagram

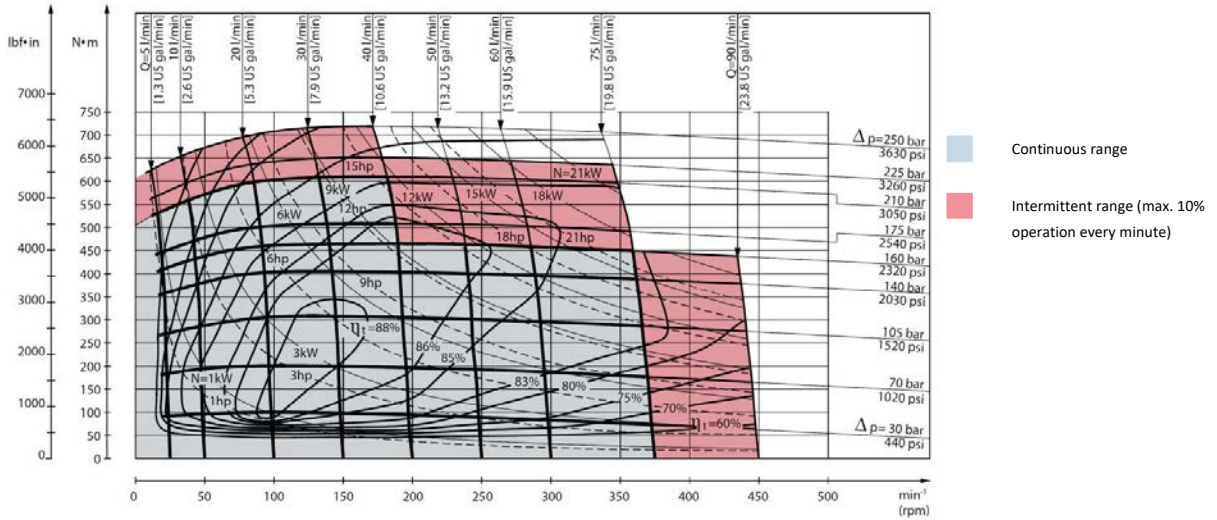

Figure 17 OMS 200 function diagram

OMS 250 function diagram

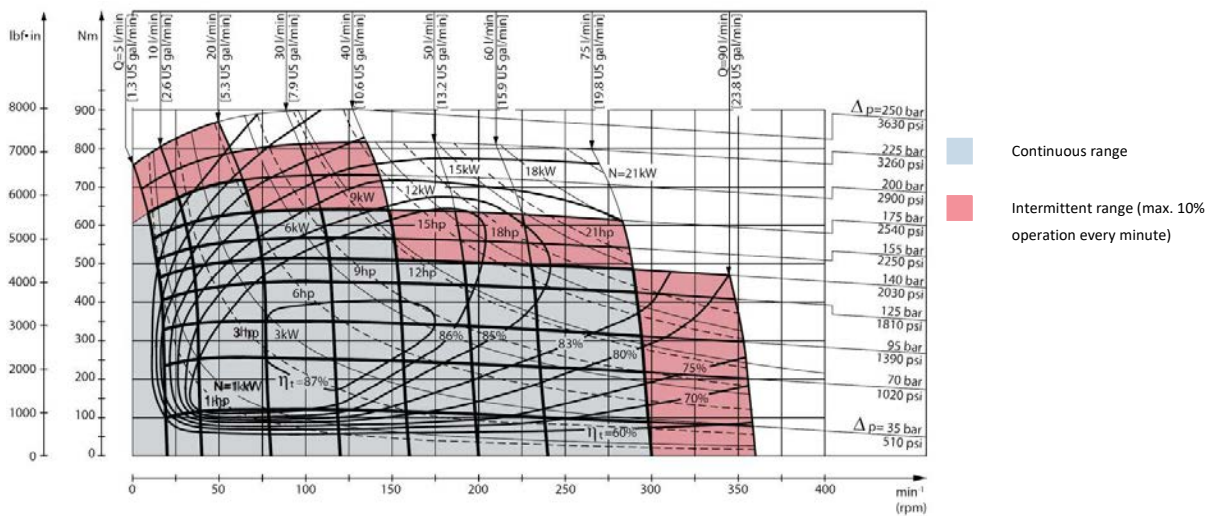

Figure 18 OMS 250 function diagram

WHITE can accept no responsibility for possible errors in catalogues, brochures, and other printed material. WHITE reserves the right to alter its products without notice. This also applies to products already on order provided that such alterations can be made without subsequent changes being necessary in specifications already agreed.

All trademarks in this material are the property of the respective companies. WHITE and the WHITE logotype are trademarks of WHITE Drive Motors & Steering LLC and WHITE Drive Motors and Steering Sp. z o.o..

All rights reserved.

Archivierung: 11/2025

OMS 315 function diagram

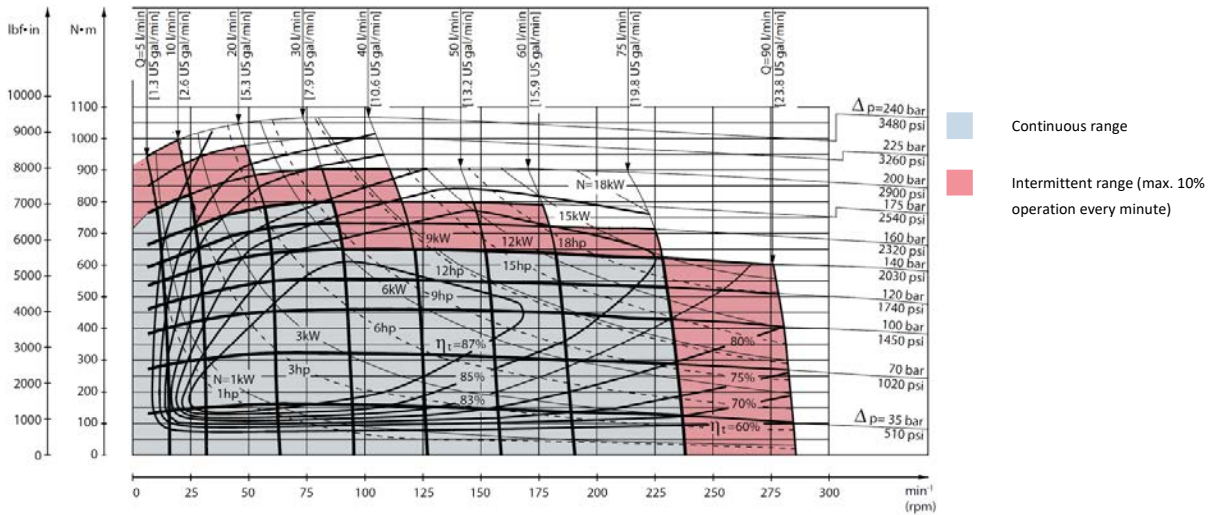

Figure 19 OMS 315 function diagram

OMS 400 function diagram

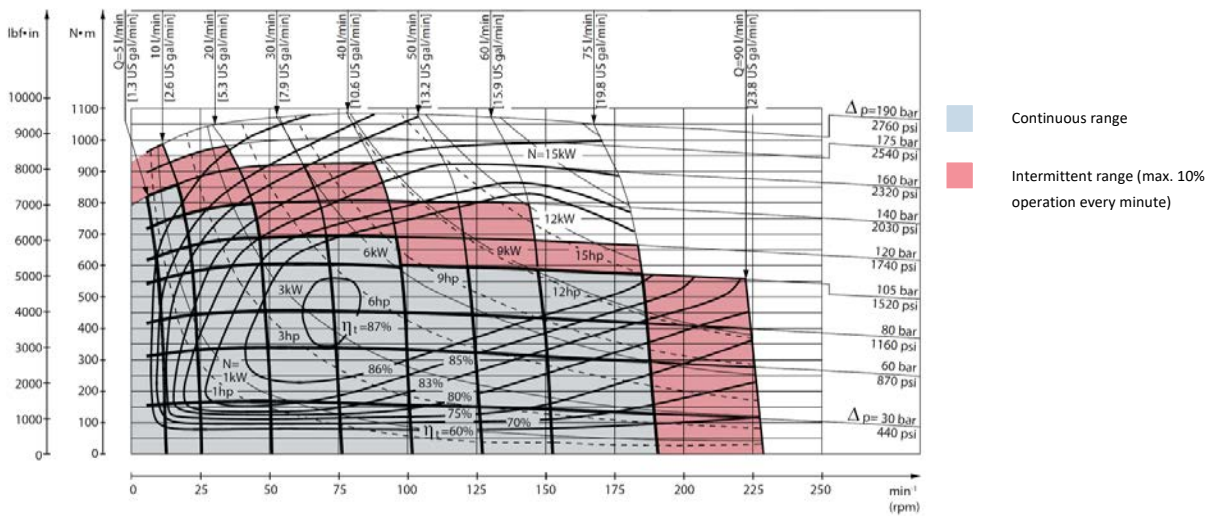

Figure 20 OMS 400 function diagram

WHITE can accept no responsibility for possible errors in catalogues, brochures, and other printed material. WHITE reserves the right to alter its products without notice. This also applies to products already on order provided that such alterations can be made without subsequent changes being necessary in specifications already agreed.

All trademarks in this material are the property of the respective companies. WHITE and the WHITE logotype are trademarks of WHITE Drive Motors & Steering LLC and WHITE Drive Motors and Steering Sp. z o.o..

All rights reserved.

Archivierung: 11/2025

OMS 500 function diagram

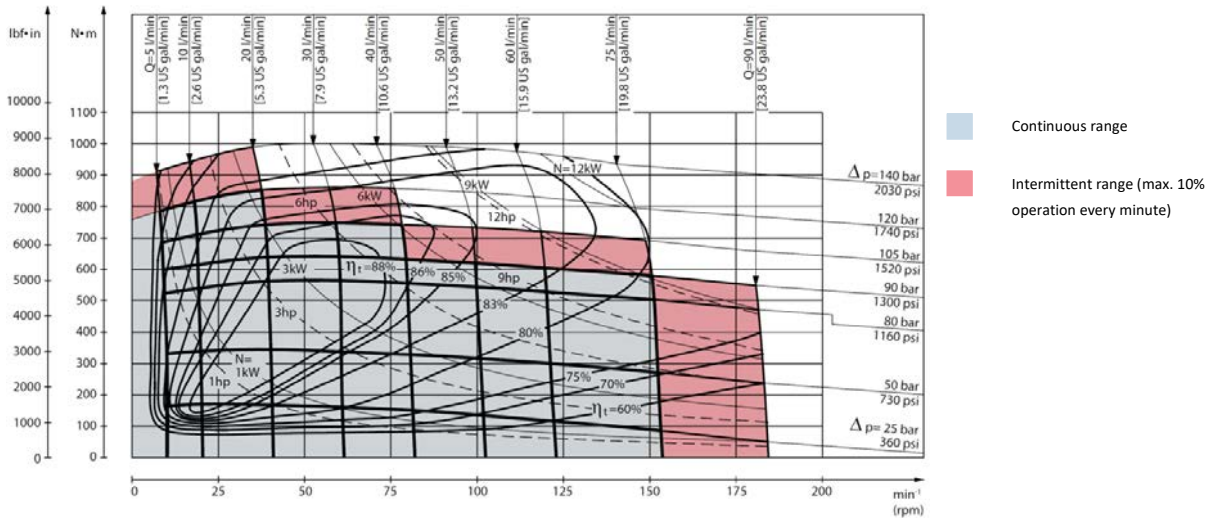

Figure 21 OMS 500 function diagram

WHITE can accept no responsibility for possible errors in catalogues, brochures, and other printed material. WHITE reserves the right to alter its products without notice. This also applies to products already on order provided that such alterations can be made without subsequent changes being necessary in specifications already agreed.

All trademarks in this material are the property of the respective companies. WHITE and the WHITE logotype are trademarks of WHITE Drive Motors & Steering LLC and WHITE Drive Motors and Steering Sp. z o.o..

All rights reserved.

Archivierung: 11/2025

Chapter 5

Shaft version

Topics:

- *OMS shaft version*
- *OMS port thread versions*

WHITE can accept no responsibility for possible errors in catalogues, brochures, and other printed material. WHITE reserves the right to alter its products without notice. This also applies to products already on order provided that such alterations can be made without subsequent changes being necessary in specifications already agreed.

All trademarks in this material are the property of the respective companies. WHITE and the WHITE logotype are trademarks of WHITE Drive Motors & Steering LLC and WHITE Drive Motors and Steering Sp. z o.o..

All rights reserved.

Archivierung: 11/2025

OMS shaft version

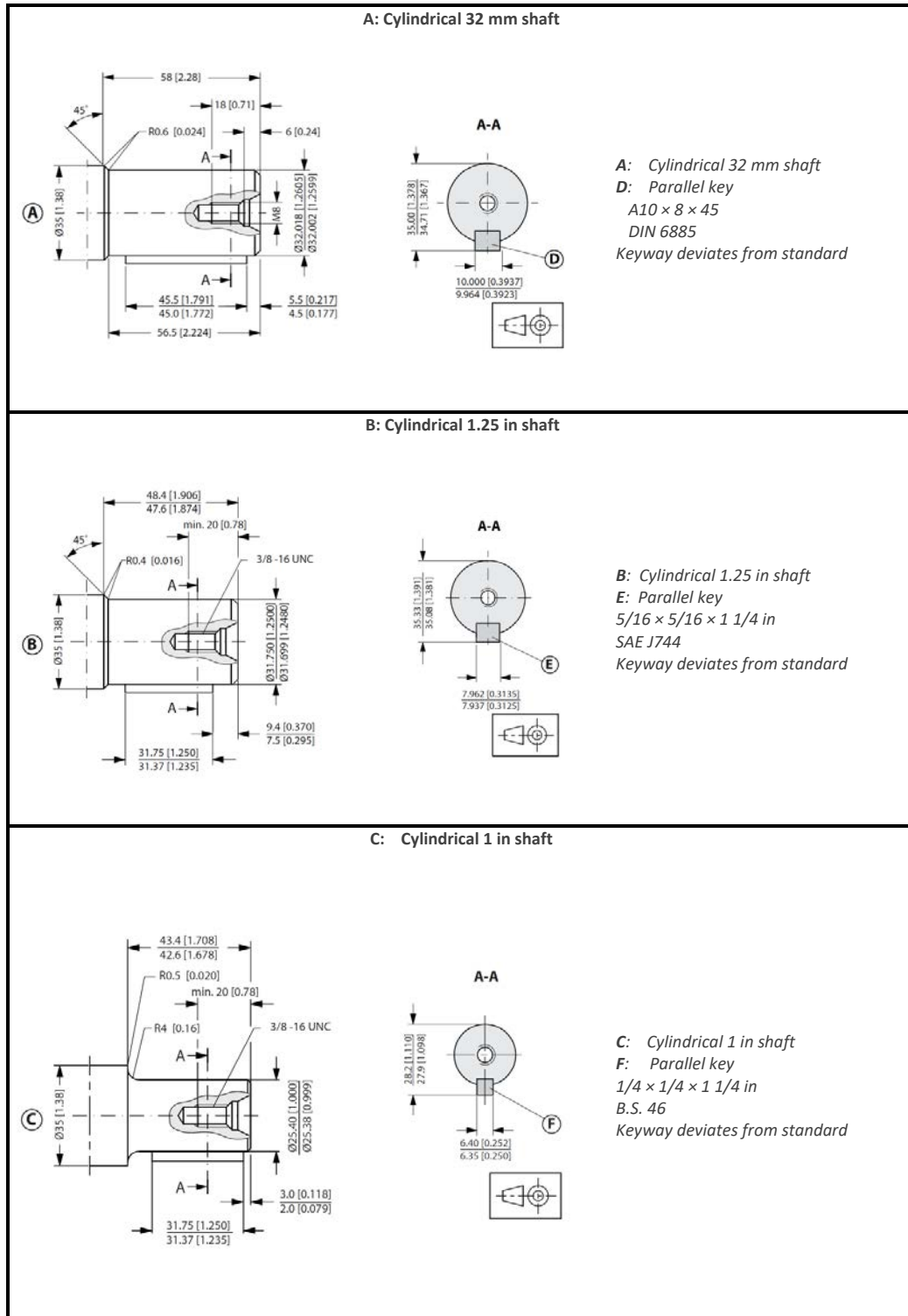

WHITE can accept no responsibility for possible errors in catalogues, brochures, and other printed material. WHITE reserves the right to alter its products without notice. This also applies to products already on order provided that such alterations can be made without subsequent changes being necessary in specifications already agreed.

All trademarks in this material are the property of the respective companies. WHITE and the WHITE logotype are trademarks of WHITE Drive Motors & Steering LLC and WHITE Drive Motors and Steering Sp. z o.o..

All rights reserved.

Archivierung: 11/2025

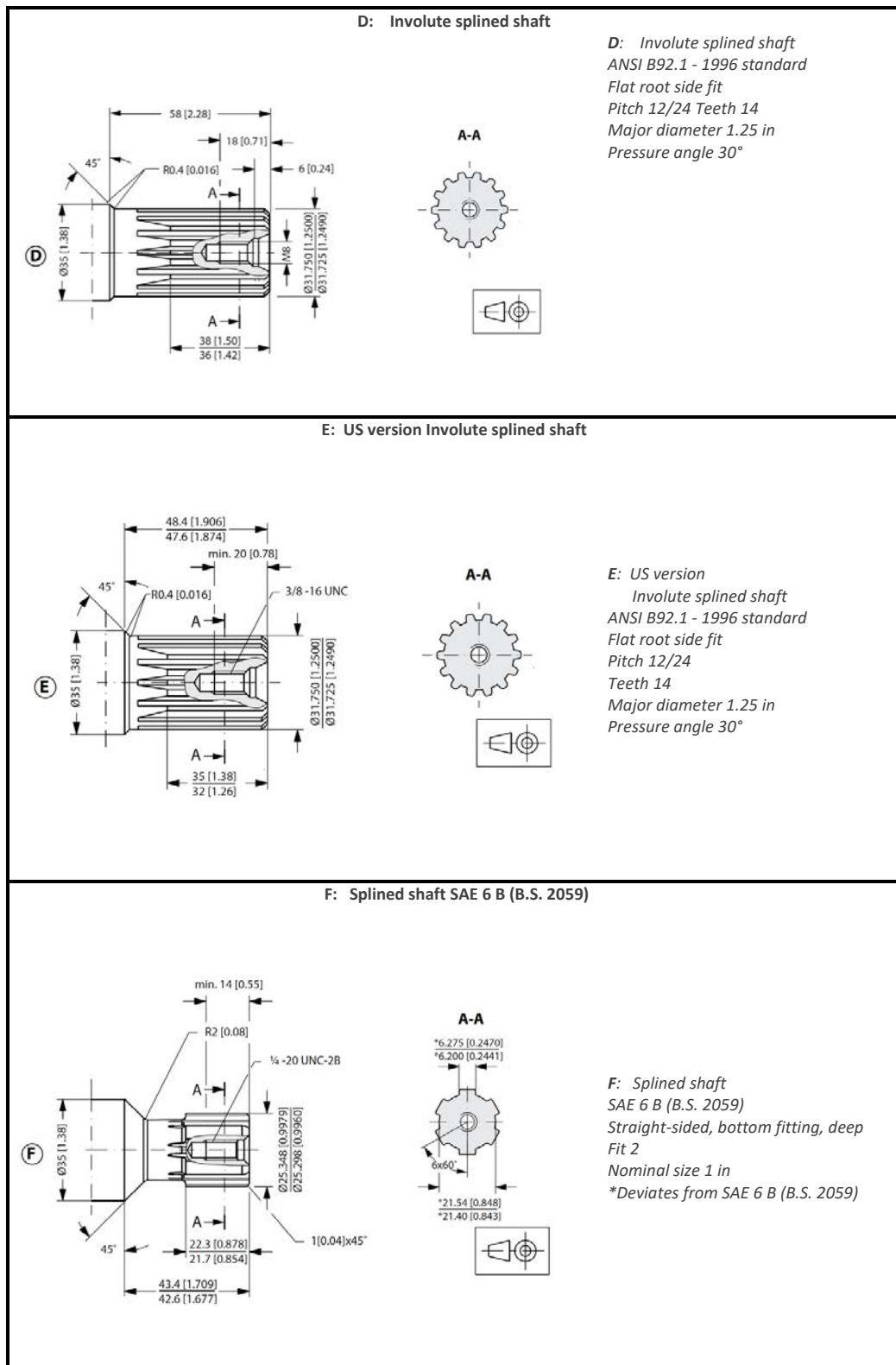

WHITE can accept no responsibility for possible errors in catalogues, brochures, and other printed material. WHITE reserves the right to alter its products without notice. This also applies to products already on order provided that such alterations can be made without subsequent changes being necessary in specifications already agreed.

All trademarks in this material are the property of the respective companies. WHITE and the WHITE logotype are trademarks of WHITE Drive Motors & Steering LLC and WHITE Drive Motors and Steering Sp. z o.o..

All rights reserved.

Archivierung: 11/2025

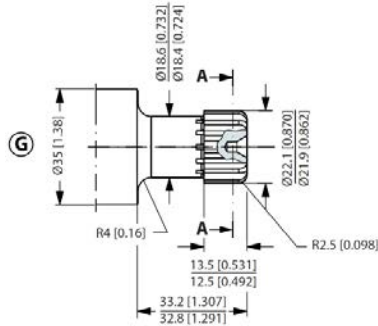
G: Involute splined shaft ANSI B92.1 - 1996 standard

A-A

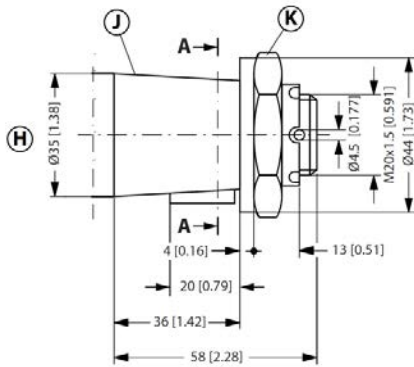

G: Involute splined shaft
 ANSI B92.1 - 1996 standard
 Flat root side fit
 Pitch 16/32
 Teeth 13
 Major dia. 0.875 in
 Pressure angle 30°

H: Tapered 35 mm shaft (ISO/R775)

A-A

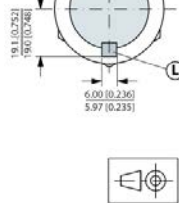

H: Tapered 35 mm shaft (ISO/R775)
 K: DIN 937
 Across flats: 41 mm
 Tightening torque: 200 ± 10 N•m
 [1770 ± 85 lbf•in]
 J: Taper 1:10
 L: Parallel key
 B6 × 6 × 20
 DIN 6885
 Keyway deviates from standard

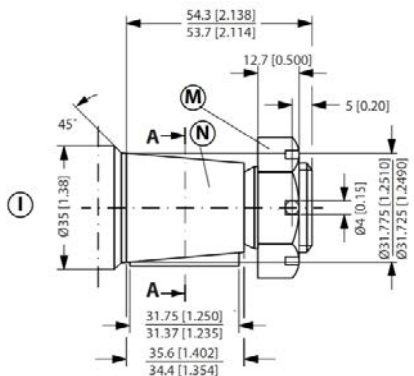
I: Tapered 1 1/4 in shaft

A-A

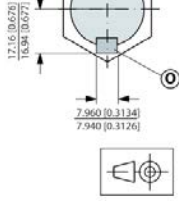

I: Tapered 1 1/4 in shaft
 M: 1 - 20 UNEF
 Across flats 1 7/16 in
 Tightening torque: 200 ± 10 N•m
 (1770 ± 85 lbf•in)
 N: Cone 1:8
 SAE J501
 O: Parallel key
 5/16 × 5/16 × 1 1/4
 SAE J501
 Keyway deviates from standard

WHITE can accept no responsibility for possible errors in catalogues, brochures, and other printed material. WHITE reserves the right to alter its products without notice. This also applies to products already on order provided that such alterations can be made without subsequent changes being necessary in specifications already agreed.

All trademarks in this material are the property of the respective companies. WHITE and the WHITE logotype are trademarks of WHITE Drive Motors & Steering LLC and WHITE Drive Motors and Steering Sp. z o.o..

All rights reserved.

Archivierung: 11/2025

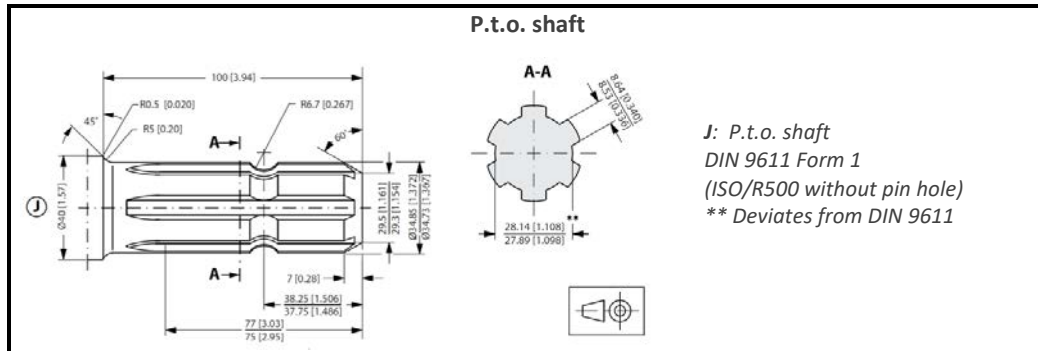

Table 21 Shaft versions

OMS port thread versions

<p>G main ports</p> 	<p>A: G main ports E: ISO 228/1 - G1/2</p>
<p>UNF main ports</p> 	<p>B: UNF main ports F: 7/8 - 14 UNF O-ring boss port</p>
<p>G drain port</p> 	<p>C: G drain port G: ISO 228/1 - G1/4</p>
<p>UNF drain port</p> 	<p>D: UNF drain port H: 7/16 - 20 UNF O-ring boss port</p>

Table 22 Port thread versions

WHITE can accept no responsibility for possible errors in catalogues, brochures, and other printed material. WHITE reserves the right to alter its products without notice. This also applies to products already on order provided that such alterations can be made without subsequent changes being necessary in specifications already agreed.

All trademarks in this material are the property of the respective companies. WHITE and the WHITE logotype are trademarks of WHITE Drive Motors & Steering LLC and WHITE Drive Motors and Steering Sp. z o.o..

All rights reserved.

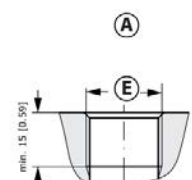
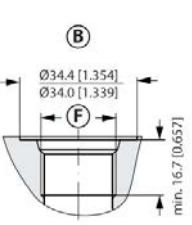
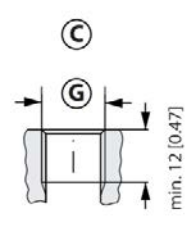
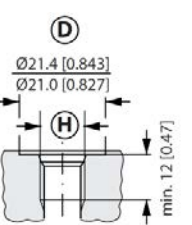
Archivierung: 11/2025

Chapter 6

OMS dimensions

Topics:

- [OMS dimensions - European version](#)
- [OMS dimensions - US version](#)

WHITE can accept no responsibility for possible errors in catalogues, brochures, and other printed material. WHITE reserves the right to alter its products without notice. This also applies to products already on order provided that such alterations can be made without subsequent changes being necessary in specifications already agreed.

All trademarks in this material are the property of the respective companies. WHITE and the WHITE logotype are trademarks of WHITE Drive Motors & Steering LLC and WHITE Drive Motors and Steering Sp. z o.o..

All rights reserved.

Archivierung: 11/2025

OMS dimensions - European version

OMS standard flange - European version

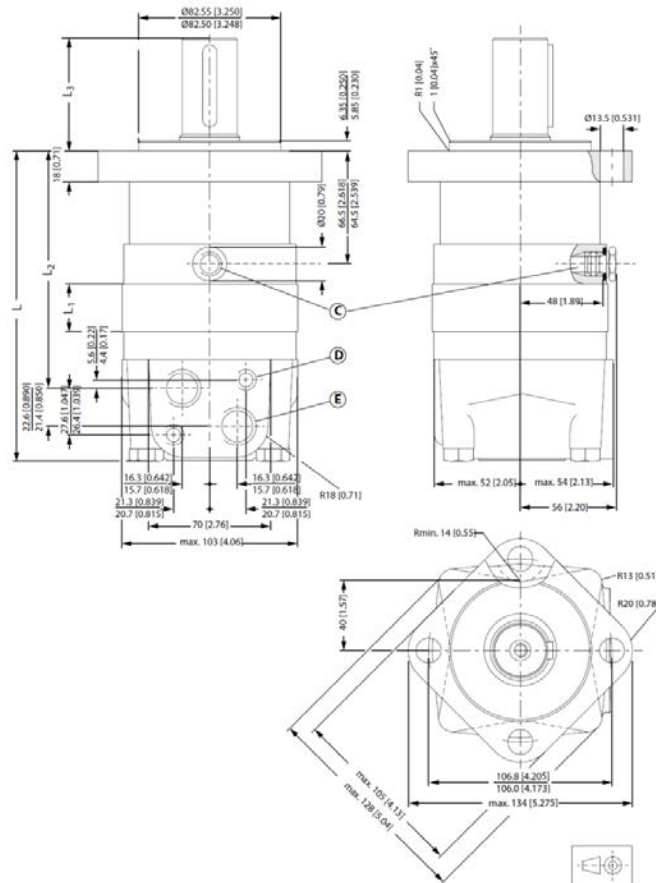

C: Drain connection, G 1/4; 12 mm [0.47 in] deep

D: M10; 13 mm [0.51 in] deep

E: G 1/2; 15 mm [0.59 in] deep

Figure 22 Standard flange EU version

Type		L _{max} mm[in]	L ₁ mm[in]	L ₂ mm[in]	Weight kg[lb]
OMS standard flange	80	168	14.0	124	9.8
		[6.61]	[0.551]	[4.88]	[21.6]
	100	172	17.4	127	10.0
		[6.77]	[0.685]	[5.00]	[22.1]
	125	176	21.8	132	10.3
		[6.93]	[0.858]	[5.20]	[22.7]
	160	182	27.8	138	10.7
		[7.17]	[1.094]	[5.43]	[23.6]
	200	189	34.8	145	11.1
		[7.44]	[1.370]	[5.71]	[24.5]
250	198	43.5	153	11.6	
	[7.80]	[1.713]	[6.02]	[25.6]	
315	209	54.8	165	12.3	
	[8.23]	[2.157]	[6.50]	[27.1]	
400	223	68.4	178	13.1	
	[8.80]	[2.693]	[7.01]	[28.9]	
500	223	68.4	178	13.1	
	[8.80]	[2.693]	[7.01]	[28.9]	

Table 23 Standard flange EU version

WHITE can accept no responsibility for possible errors in catalogues, brochures, and other printed material. WHITE reserves the right to alter its products without notice. This also applies to products already on order provided that such alterations can be made without subsequent changes being necessary in specifications already agreed.

All trademarks in this material are the property of the respective companies. WHITE and the WHITE logotype are trademarks of WHITE Drive Motors & Steering LLC and WHITE Drive Motors and Steering Sp. z o.o..

All rights reserved.

Archivierung: 11/2025

Output shaft		L ₃ mm[in]
All shafts (except P.to. shaft)	Maximum	67 [2.64]
	Minimum	65 [2.56]
P.t.o. shaft	Maximum	109 [4.29]
	Minimum	107 [4.21]

Table 24 Output shaft

WHITE can accept no responsibility for possible errors in catalogues, brochures, and other printed material. WHITE reserves the right to alter its products without notice. This also applies to products already on order provided that such alterations can be made without subsequent changes being necessary in specifications already agreed.

All trademarks in this material are the property of the respective companies. WHITE and the WHITE logotype are trademarks of WHITE Drive Motors & Steering LLC and WHITE Drive Motors and Steering Sp. z o.o..

All rights reserved.

Archivierung: 11/2025

OMS special flange - European version

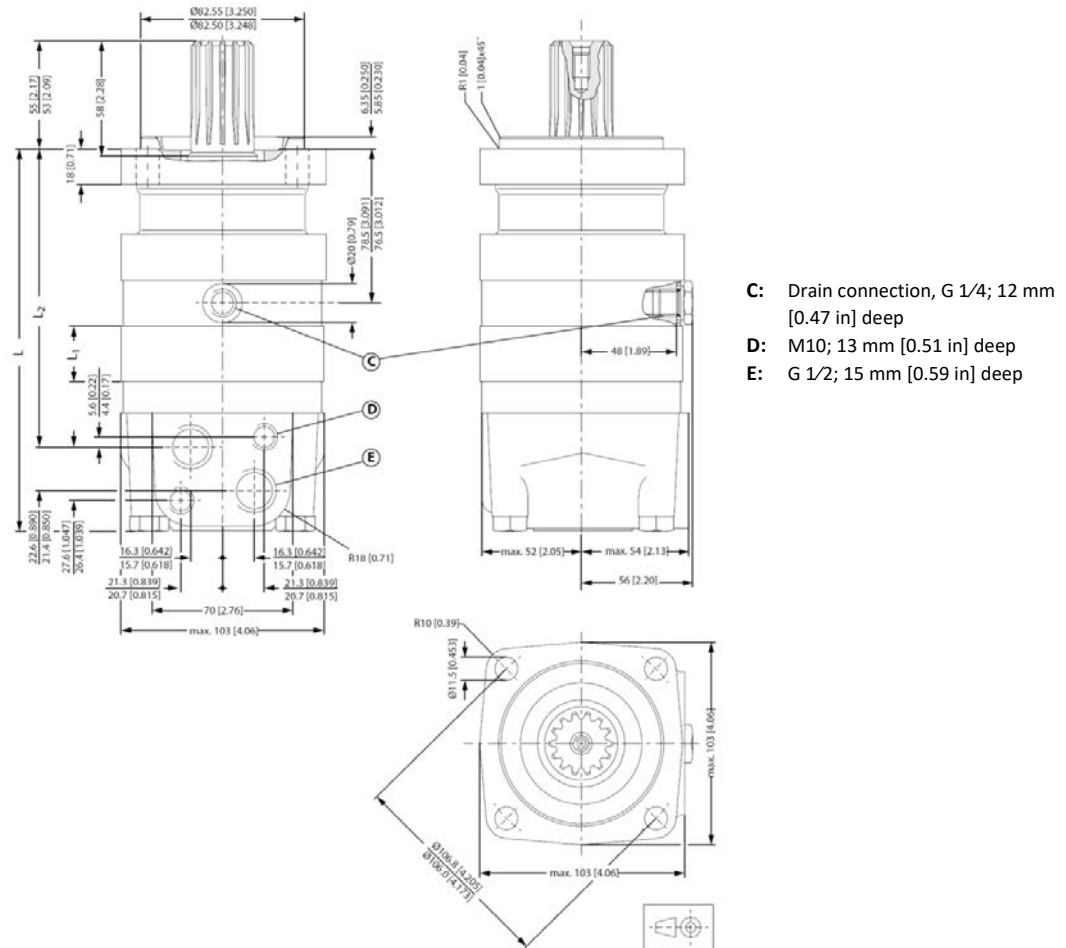

Figure 23 Special flange - EU version

Type		L _{max} mm[in]	L ₁ mm[in]	L ₂ mm[in]	Weight kg[lb]
OMS Special flange	80	180 [7.09]	14 [0.551]	136 [5.35]	10.2 [22.5]
	100	183 [7.20]	17.4 [0.685]	140 [5.51]	10.4 [22.9]
	125	188 [7.40]	21.8 [0.858]	144 [5.67]	10.7 [23.6]
	160	194 [7.64]	27.8 [1.094]	150 [5.91]	11.1 [24.5]
	200	201 [7.91]	34.8 [1.370]	157 [6.18]	11.5 [25.4]
	250	210 [8.27]	43.5 [1.713]	166 [6.54]	12 [26.5]
	315	221 [8.70]	54.8 [2.157]	177 [6.97]	12.7 [28.0]
	400	232 [9.13]	68.4 [2.693]	190 [7.48]	13.5 [29.8]

Table 25 Special flange EU version

WHITE can accept no responsibility for possible errors in catalogues, brochures, and other printed material. WHITE reserves the right to alter its products without notice. This also applies to products already on order provided that such alterations can be made without subsequent changes being necessary in specifications already agreed.

All trademarks in this material are the property of the respective companies. WHITE and the WHITE logotype are trademarks of WHITE Drive Motors & Steering LLC and WHITE Drive Motors and Steering Sp. z o.o..

All rights reserved.

Archivierung: 11/2025

OMS wheel - European version

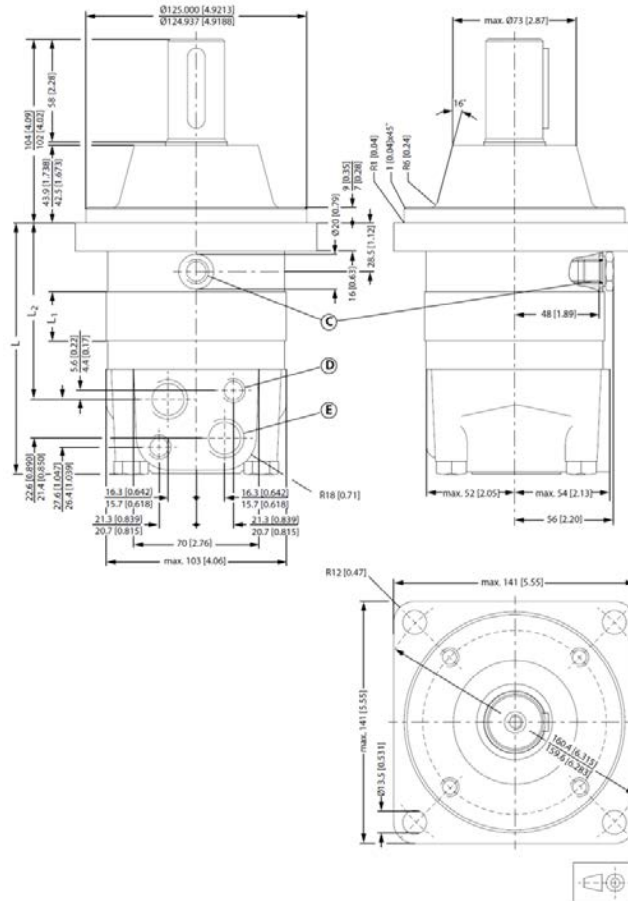

- C:** Drain connection, G 1/4; 12 mm [0.47 in] deep
D: M10; 13 mm [0.51 in] deep
E: G 1/2; 15 mm [0.59 in] deep

Figure 24 Wheel - EU version

Type	L_{max} mm[in]	L_1 mm[in]	L_2 mm[in]	Weight kg[lb]	
OMSW	80	131 [5.16]	14.0 [0.551]	87 [3.43]	10.3 [22.7]
	100	135 [5.31]	17.4 [0.685]	90 [3.54]	10.5 [23.1]
	125	139 [5.47]	21.8 [0.858]	95 [3.74]	10.8 [23.8]
	160	145 [5.70]	27.8 [1.094]	101 [3.98]	11.2 [24.7]
	200	152 [5.98]	34.8 [1.370]	108 [4.25]	11.6 [25.6]
	250	161 [6.34]	43.5 [1.713]	116 [4.57]	12.1 [26.7]
	315	172 [6.77]	54.8 [2.157]	128 [5.04]	12.8 [28.2]
	400	186 [7.32]	68.4 [2.693]	142 [5.59]	13.6 [30.0]
	500	186 [7.32]	68.4 [2.693]	142 [5.59]	13.6 [30.0]

Table 26 Wheel EU version

WHITE can accept no responsibility for possible errors in catalogues, brochures, and other printed material. WHITE reserves the right to alter its products without notice. This also applies to products already on order provided that such alterations can be made without subsequent changes being necessary in specifications already agreed.

All trademarks in this material are the property of the respective companies. WHITE and the WHITE logotype are trademarks of WHITE Drive Motors & Steering LLC and WHITE Drive Motors and Steering Sp. z o.o..

All rights reserved.

Archivierung: 11/2025

OMS short - European version

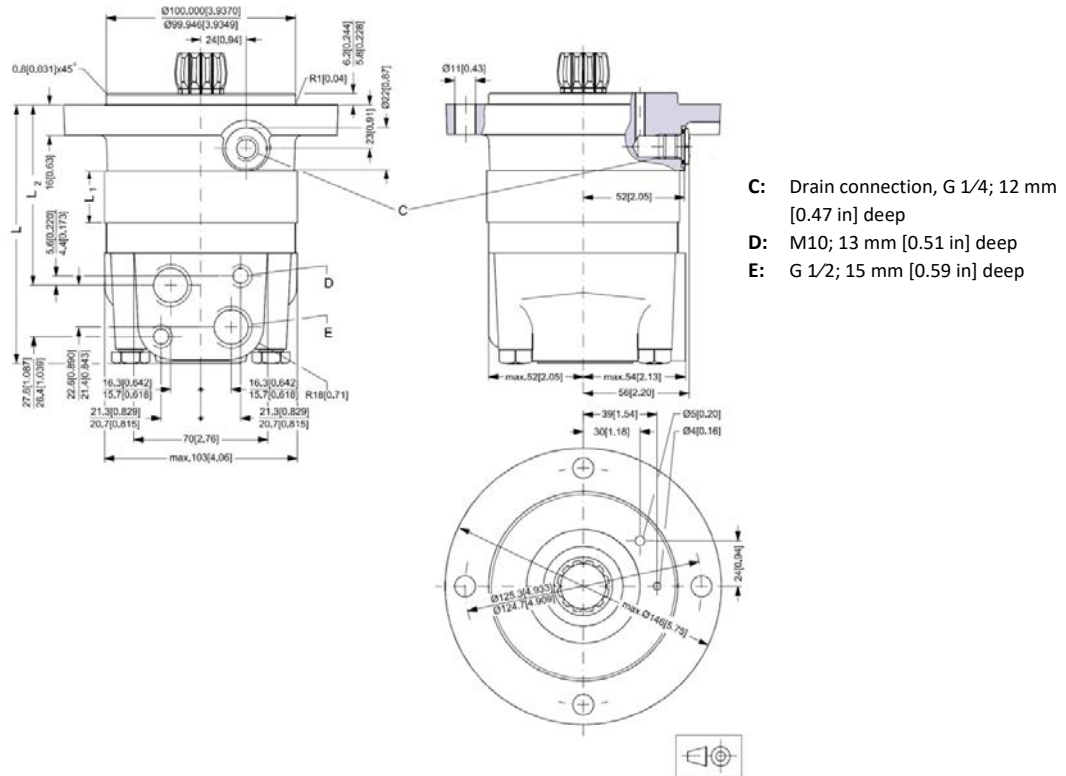

Figure 25 Short EU version

Type		L _{max} mm[in]	L ₁ mm[in]	L ₂ mm[in]	Weight kg[lb]
OMSS	80	126 [4.96]	14.0 [0.551]	83 [3.27]	7.8 [17.2]
	100	129 [5.09]	17.4 [0.685]	86 [3.39]	8 [17.6]
	125	134 [5.28]	21.8 [0.858]	90 [3.54]	8.3 [18.3]
	160	140 [5.51]	27.8 [1.094]	96 [3.78]	8.7 [19.2]
	200	147 [5.79]	34.8 [1.370]	103 [4.06]	9.1 [20.1]
	250	156 [6.14]	43.5 [1.713]	112 [4.41]	9.6 [21.2]
	315	167 [6.57]	54.8 [2.157]	123 [4.84]	10.3 [22.7]
	400	180 [7.09]	68.4 [2.693]	137 [5.39]	11.1 [24.3]
	500	180 [7.09]	68.4 [2.693]	137 [5.39]	11.1 [24.3]

Table 27 Short EU version

WHITE can accept no responsibility for possible errors in catalogues, brochures, and other printed material. WHITE reserves the right to alter its products without notice. This also applies to products already on order provided that such alterations can be made without subsequent changes being necessary in specifications already agreed.

All trademarks in this material are the property of the respective companies. WHITE and the WHITE logotype are trademarks of WHITE Drive Motors & Steering LLC and WHITE Drive Motors and Steering Sp. z o.o..

All rights reserved.

Archivierung: 11/2025

OMS dimensions - US version

OMS standard flange - US version

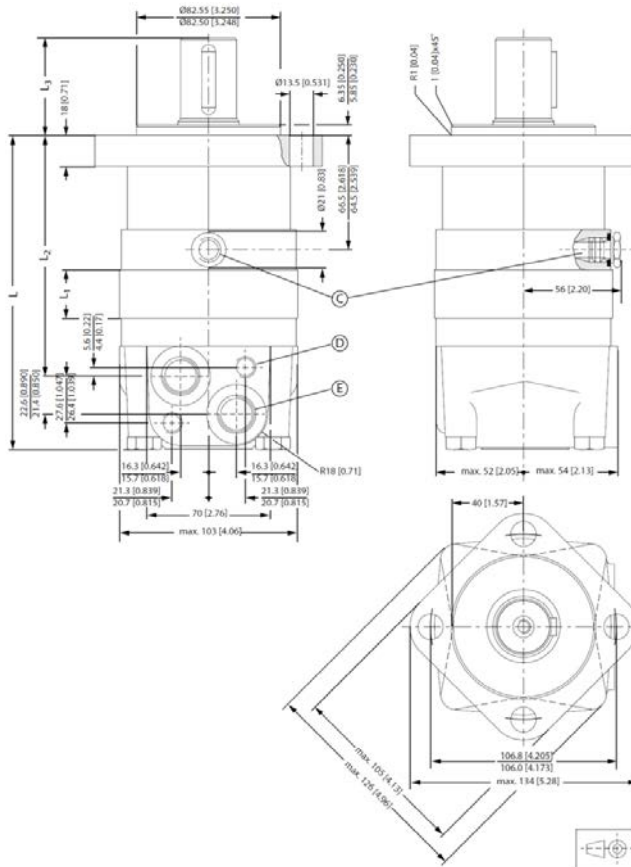

- C:** Drain connection, 7/16 - 20 UNF; 12 mm [0.47 in] deep, O-ring boss port
- D:** M10; 13 mm [0.51 in] deep
- E:** 7/8 - 14 UNF; 16.7 mm [0.657 in] deep, O-ring boss port

Figure 26 Standard flange US version

Type		L _{max} mm[in]	L ₁ mm[in]	L ₂ mm[in]	Weight kg[lb]
OMS	80	168 [6.61]	14.0 [0.551]	124 [4.88]	9.8 [21.6]
	100	172 [6.77]	17.4 [0.685]	127 [5.00]	10.0 [22.1]
	125	176 [6.93]	21.8 [0.858]	132 [5.20]	10.3 [22.7]
	160	182 [7.17]	27.8 [1.094]	138 [5.43]	10.7 [23.6]
	200	189 [7.44]	34.8 [1.370]	145 [5.71]	11.1 [24.5]
	250	198 [7.80]	43.5 [1.713]	153 [6.02]	11.6 [25.6]
	315	209 [8.23]	54.8 [2.157]	165 [5.60]	12.3 [27.1]
	400	223 [8.80]	68.4 [2.693]	178 [7.01]	13.1 [28.9]
	500	223 [8.80]	68.4 [2.693]	178 [7.01]	13.1 [28.9]

Table 28 Standard US version

WHITE can accept no responsibility for possible errors in catalogues, brochures, and other printed material. WHITE reserves the right to alter its products without notice. This also applies to products already on order provided that such alterations can be made without subsequent changes being necessary in specifications already agreed.

All trademarks in this material are the property of the respective companies. WHITE and the WHITE logotype are trademarks of WHITE Drive Motors & Steering LLC and WHITE Drive Motors and Steering Sp. z o.o..

All rights reserved.

Archivierung: 11/2025

Output shaft		L ₃ mm[in]
Cyl.1.25 in, Splined 1.25 in	Maximum	57 [2.24]
	Minimum	55 [2.17]
Tapered 1.25 in	Maximum	67 [2.64]
	Minimum	65 [2.56]

Table 29 Output shaft US version

OMS A2 flange - US version

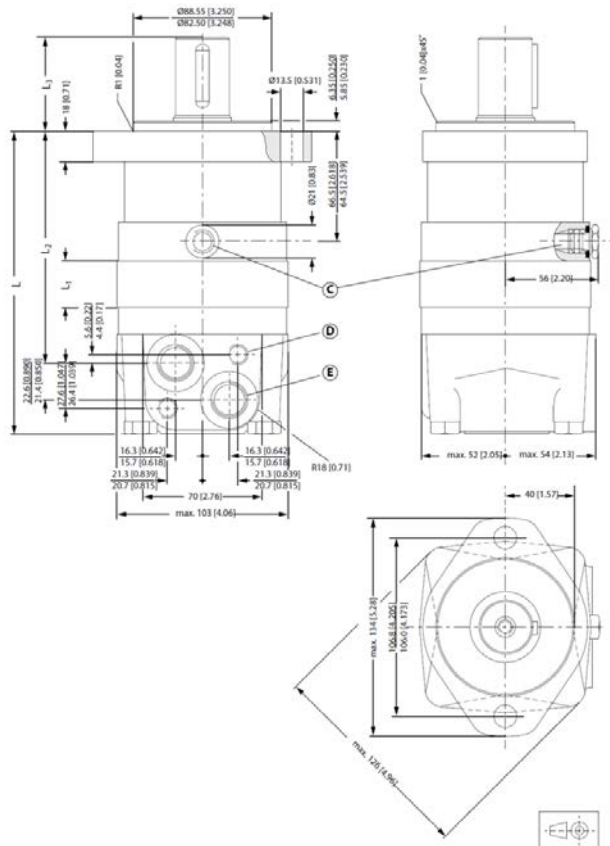

Figure 27 A2 flange US version

- C:** Drain connection, 7/16 - 20 UNF; 12 mm [0.47 in] deep, O-ring boss port
- D:** M10; 13 mm [0.51 in] deep
- E:** 7/8 - 14 UNF; 16.7 mm [0.657 in] deep, O-ring boss port

WHITE can accept no responsibility for possible errors in catalogues, brochures, and other printed material. WHITE reserves the right to alter its products without notice. This also applies to products already on order provided that such alterations can be made without subsequent changes being necessary in specifications already agreed.

All trademarks in this material are the property of the respective companies. WHITE and the WHITE logotype are trademarks of WHITE Drive Motors & Steering LLC and WHITE Drive Motors and Steering Sp. z o.o..

All rights reserved.

Archivierung: 11/2025

Type		L _{max} mm[in]	L ₁ mm[in]	L ₂ mm[in]	Weight kg[lb]
OMS	80	168 [6.61]	14.0 [0.551]	124 [4.88]	9.8 [21.6]
	100	172 [6.77]	17.4 [0.685]	127 [5.00]	10.0 [22.1]
	125	176 [6.93]	21.8 [0.858]	132 [5.20]	10.3 [22.7]
	160	182 [7.17]	27.8 [1.094]	138 [5.43]	10.7 [23.6]
	200	189 [7.44]	34.8 [1.370]	145 [5.71]	11.1 [24.5]
	250	198 [7.80]	43.5 [1.713]	153 [6.02]	11.6 [25.6]
	315	209 [8.23]	54.8 [2.157]	165 [5.60]	12.3 [27.1]
	400	223 [8.80]	68.4 [2.693]	178 [7.01]	13.1 [28.9]
	500	223 [8.80]	68.4 [2.693]	178 [7.01]	13.1 [28.9]

Table 30 A2 flange US version

Output shaft		L ₃ mm[in]
Cyl.1 in, Splined 1 in	Maximum	52 [2.05]
	Minimum	50 [1.97]
Cyl.1.25 in, Splined 1.25 in	Maximum	57 [2.24]
	Minimum	55 [2.17]
Tapered 1.25 in	Maximum	67 [2.64]
	Minimum	65 [2.56]

Table 31 Output shaft US version

WHITE can accept no responsibility for possible errors in catalogues, brochures, and other printed material. WHITE reserves the right to alter its products without notice. This also applies to products already on order provided that such alterations can be made without subsequent changes being necessary in specifications already agreed.

All trademarks in this material are the property of the respective companies. WHITE and the WHITE logotype are trademarks of WHITE Drive Motors & Steering LLC and WHITE Drive Motors and Steering Sp. z o.o..

All rights reserved.

Archivierung: 11/2025

OMS magneto flange - US version

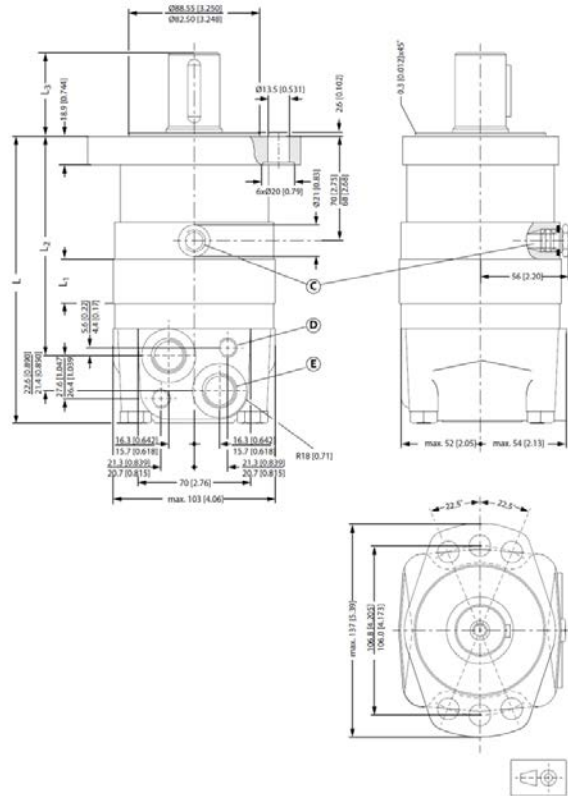

- C:** Drain connection, 7/16 - 20 UNF; 12 mm [0.47 in] deep, O-ring boss port
D: M10; 13 mm [0.51 in] deep
E: 7/8 - 14 UNF; 16.7 mm [0.657 in] deep, O-ring boss port

Figure 28 Magneto flange

Type		L _{max} mm[in]	L ₁ mm[in]	L ₂ mm[in]	Weight kg[lb]
OMS	80	172 [6.77]	14.0 [0.551]	124 [4.88]	9.8 [21.6]
	100	175 [6.89]	17.4 [0.685]	127 [5.00]	10.0 [22.1]
	125	180 [7.08]	21.8 [0.858]	132 [5.20]	10.3 [22.7]
	160	186 [7.32]	27.8 [1.094]	138 [5.43]	10.7 [23.6]
	200	193 [7.60]	34.8 [1.370]	145 [5.71]	11.1 [24.5]
	250	201 [7.91]	43.5 [1.713]	153 [6.02]	11.6 [25.6]
	315	213 [8.39]	54.8 [2.157]	165 [5.60]	12.3 [27.1]
	400	226 [8.90]	68.4 [2.693]	178 [7.01]	13.1 [28.9]
	500	226 [8.90]	68.4 [2.693]	178 [7.01]	13.1 [28.9]

Table 32 Magneto flange US version

WHITE can accept no responsibility for possible errors in catalogues, brochures, and other printed material. WHITE reserves the right to alter its products without notice. This also applies to products already on order provided that such alterations can be made without subsequent changes being necessary in specifications already agreed.

All trademarks in this material are the property of the respective companies. WHITE and the WHITE logotype are trademarks of WHITE Drive Motors & Steering LLC and WHITE Drive Motors and Steering Sp. z o.o..

All rights reserved.

Archivierung: 11/2025

Output shaft		L ₃ mm[in]
Cyl.1 in, Splined 1 in	Maximum	49 [1.93]
	Minimum	47 [1.85]
Cyl.1.25 in, Splined 1.25 in	Maximum	54 [2.13]
	Minimum	52 [2.05]

Table 33 Output shaft US version

OMS SAE-B flange - US version

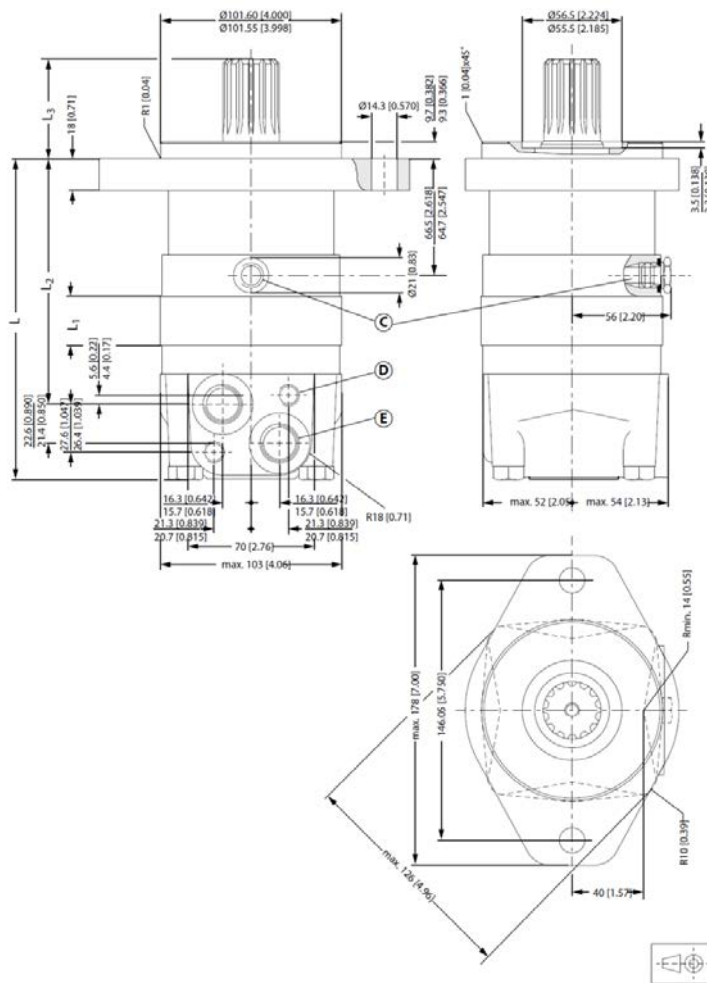

Figure 29 SAE B flange US version

WHITE can accept no responsibility for possible errors in catalogues, brochures, and other printed material. WHITE reserves the right to alter its products without notice. This also applies to products already on order provided that such alterations can be made without subsequent changes being necessary in specifications already agreed.

All trademarks in this material are the property of the respective companies. WHITE and the WHITE logotype are trademarks of WHITE Drive Motors & Steering LLC and WHITE Drive Motors and Steering Sp. z o.o..

All rights reserved.

Archivierung: 11/2025

Type		L _{max} mm[in]	L ₁ mm[in]	L ₂ mm[in]	Weight kg[lb]
OMS	80	168 [6.61]	14.0 [0.551]	124 [4.88]	9.8 [21.6]
	100	172 [6.77]	17.4 [0.685]	127 [5.00]	10.0 [22.1]
	125	176 [6.93]	21.8 [0.858]	132 [5.20]	10.3 [22.7]
	160	182 [7.17]	27.8 [1.094]	138 [5.43]	10.7 [23.6]
	200	189 [7.44]	34.8 [1.370]	145 [5.71]	11.1 [24.5]
	250	198 [7.80]	43.5 [1.713]	153 [6.02]	11.6 [25.6]
	315	209 [8.23]	54.8 [2.157]	165 [5.60]	12.3 [27.1]
	400	223 [8.80]	68.4 [2.693]	178 [7.01]	13.1 [28.9]
	500	223 [8.80]	68.4 [2.693]	178 [7.01]	13.1 [28.9]

Table 34 SAE B flange US version

Output shaft		L ₃ mm[in]
Splined 1.25 in	Maximum	57 [2.24]
	Minimum	55 [2.17]
Splined 0.875 in	Maximum	42 [1.65]
	Minimum	40 [1.57]

Table 35 Output shaft US version

WHITE can accept no responsibility for possible errors in catalogues, brochures, and other printed material. WHITE reserves the right to alter its products without notice. This also applies to products already on order provided that such alterations can be made without subsequent changes being necessary in specifications already agreed.

All trademarks in this material are the property of the respective companies. WHITE and the WHITE logotype are trademarks of WHITE Drive Motors & Steering LLC and WHITE Drive Motors and Steering Sp. z o.o..

All rights reserved.

Archivierung: 11/2025

OMS Wheel - US version

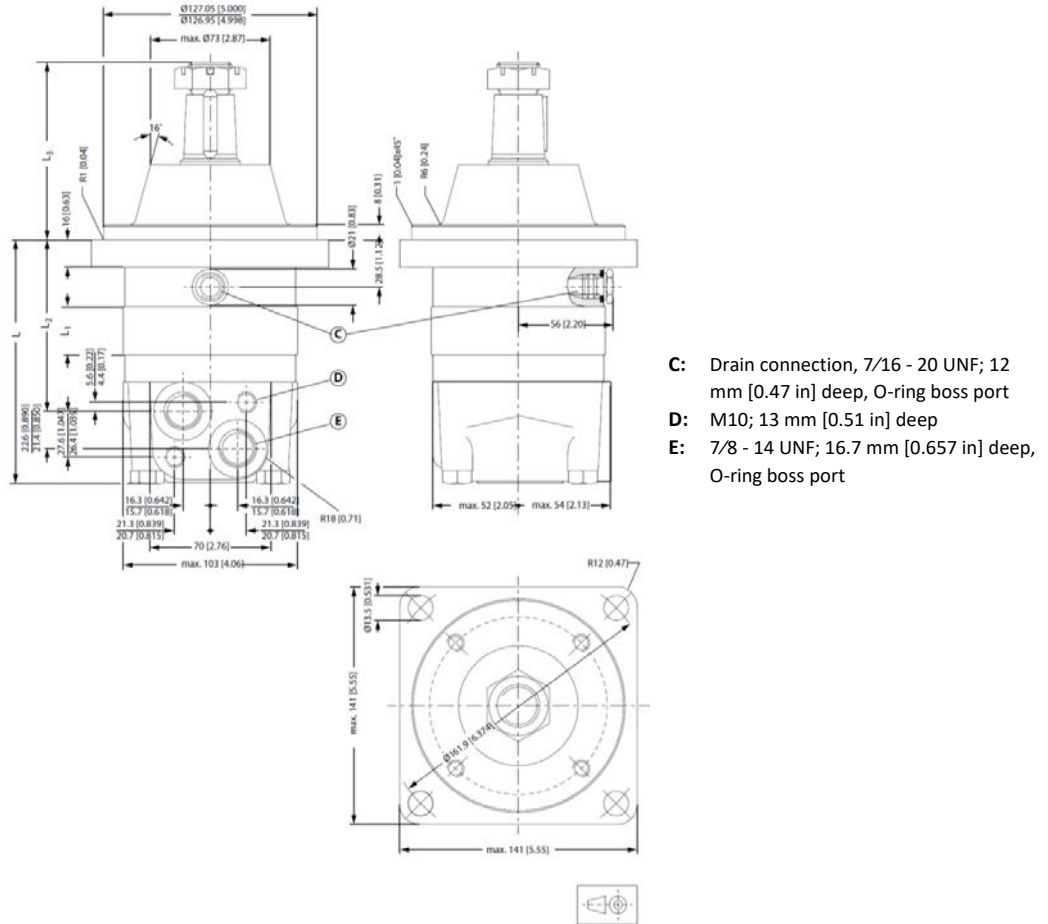

Figure 30 Wheel US version

Type	L_{max} mm[in]	L_1 mm[in]	L_2 mm[in]	Weight kg[lb]
OMS	80	130 [5.12]	14.0 [0.551]	88 [22.7]
	100	133 [5.24]	17.4 [0.685]	10.5 [23.1]
	125	139 [5.47]	21.8 [0.858]	10.8 [23.8]
	160	145 [5.71]	27.8 [1.094]	11.2 [24.7]
	200	152 [5.98]	34.8 [1.370]	11.6 [25.6]
	250	161 [6.34]	43.5 [1.713]	12.1 [26.7]
	315	172 [6.77]	54.8 [2.157]	12.8 [28.2]
	400	186 [7.32]	68.4 [2.693]	13.6 [30.0]
	500	186 [7.32]	68.4 [2.693]	13.6 [30.0]

Table 36 Wheel US version

WHITE can accept no responsibility for possible errors in catalogues, brochures, and other printed material. WHITE reserves the right to alter its products without notice. This also applies to products already on order provided that such alterations can be made without subsequent changes being necessary in specifications already agreed.

All trademarks in this material are the property of the respective companies. WHITE and the WHITE logotype are trademarks of WHITE Drive Motors & Steering LLC and WHITE Drive Motors and Steering Sp. z o.o..

All rights reserved.

Archivierung: 11/2025

Output shaft		L ₃ mm[in]
Cyl.1.25 in	Maximum	94 [3.70]
	Minimum	92 [3.62]
Tapered 1.25 in	Maximum	104 [4.09]
	Minimum	102 [4.02]

Table 37 Output shaft US version

OMS short - US version

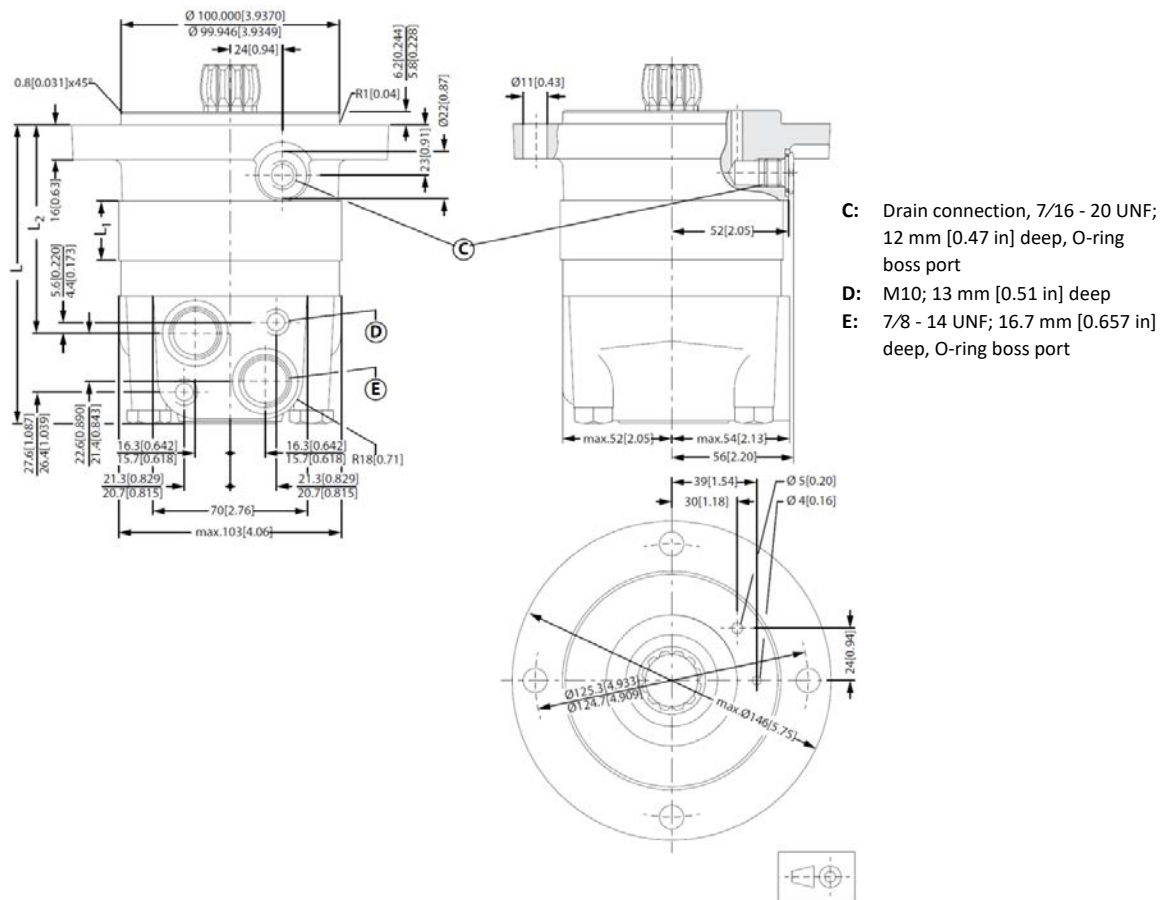

Figure 31 OMSS US version

WHITE can accept no responsibility for possible errors in catalogues, brochures, and other printed material. WHITE reserves the right to alter its products without notice. This also applies to products already on order provided that such alterations can be made without subsequent changes being necessary in specifications already agreed.

All trademarks in this material are the property of the respective companies. WHITE and the WHITE logotype are trademarks of WHITE Drive Motors & Steering LLC and WHITE Drive Motors and Steering Sp. z o.o..

All rights reserved.

Archivierung: 11/2025

Type		L _{max} mm[in]	L ₁ mm[in]	L ₂ mm[in]	Weight kg[lb]
OMSS	80	126 [4.96]	14.0 [0.551]	83 [3.27]	7.8 [17.2]
	100	129 [5.09]	17.4 [0.685]	86 [3.39]	8 [17.6]
	125	134 [5.28]	21.8 [0.858]	90 [3.54]	8.3 [18.3]
	160	140 [5.51]	27.8 [1.094]	96 [3.78]	8.7 [19.2]
	200	147 [5.79]	34.8 [1.370]	103 [4.06]	9.1 [20.1]
	250	156 [6.14]	43.5 [1.713]	112 [4.41]	9.6 [21.2]
	315	167 [6.57]	54.8 [2.157]	123 [4.84]	10.3 [22.7]
	400	180 [7.09]	68.4 [2.693]	137 [5.39]	11.1 [24.3]
	500	180 [7.09]	68.4 [2.693]	137 [5.39]	11.1 [24.3]

Table 38 Wheel US version

Output shaft		L ₃ mm[in]
Cyl. 1.25 in	Maximum	94 [3.70]
	Minimum	92 [3.70]
Tapered 1.25 in	Maximum	104 [4.09]
	Minimum	102 [4.02]

Table 39 Output shaft US version

WHITE can accept no responsibility for possible errors in catalogues, brochures, and other printed material. WHITE reserves the right to alter its products without notice. This also applies to products already on order provided that such alterations can be made without subsequent changes being necessary in specifications already agreed.

All trademarks in this material are the property of the respective companies. WHITE and the WHITE logotype are trademarks of WHITE Drive Motors & Steering LLC and WHITE Drive Motors and Steering Sp. z o.o..

All rights reserved.

Archivierung: 11/2025

Chapter 7

OMSS

Topics:

- *Installing the OMSS*
- *Attached component dimensions*
- *Internal spline data for the component to be attached*
- *Motor or attached component drain connection*

WHITE can accept no responsibility for possible errors in catalogues, brochures, and other printed material. WHITE reserves the right to alter its products without notice. This also applies to products already on order provided that such alterations can be made without subsequent changes being necessary in specifications already agreed.

All trademarks in this material are the property of the respective companies. WHITE and the WHITE logotype are trademarks of WHITE Drive Motors & Steering LLC and WHITE Drive Motors and Steering Sp. z o.o..

All rights reserved.

Archivierung: 11/2025

Installing the OMSS

The cardan shaft of the OMSS motor acts as an “output shaft”. Because of the movement of the shaft, no seal can be fitted at the shaft output.

Internal oil leakage from the motor will therefore flow into the attached component.

During start and operation it is important that the spline connection and the bearings in the attached component receive oil and are adequately lubricated. To ensure that the spline connection receives sufficient oil, a conical sealing ring between the shaft of the attached component and the motor intermediate plate is recommended. This method is used in the OMS.

The conical sealing ring (code. no. 633B9023) is supplied with the motor.

To ensure that oil runs to the bearings and other parts of the attached component, the stop plate must have a hole in it (see fig. below).

We recommend an O-ring between motor and attached component. The O-ring (code no. 151F1033) is supplied with the motor. If motor and attached component have been separated, remember to refill before starting up. Fill the oil through the drain connection.

Attached component dimensions

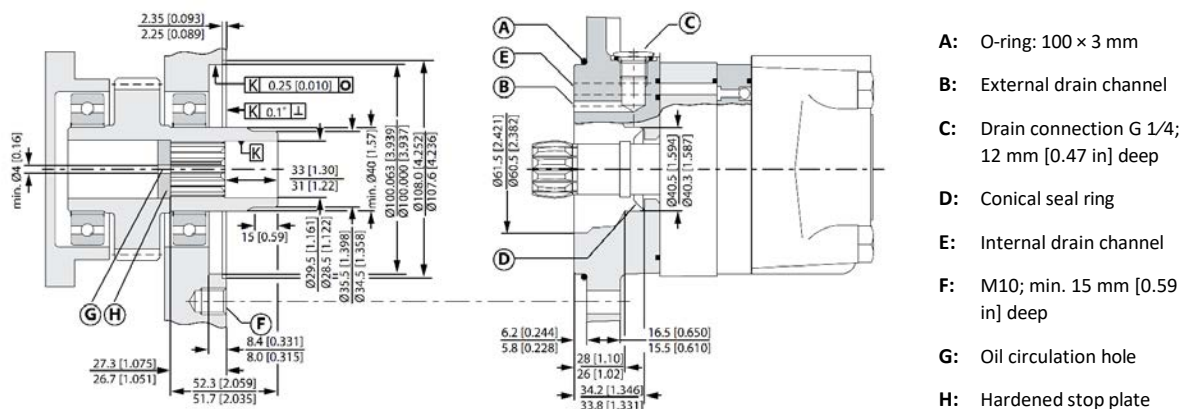

Figure 32 OMSS dimensions of the attached component

Internal spline data for the component to be attached

The attached component must have internal splines corresponding to the external splines on the motor cardan shaft (see drawing below).

Material

Case hardening steel with a tensile strength corresponding at least to 20 MoCr4 (900 N/mm²) or SAE 8620.

Hardening specification

- On the surface: HV = 750 ± 50
- 0.7 ± 0.2 mm under the surface: HV = 560

Flat root side fit		mm	[in]
Number of teeth	z	12	
Pitch	DP	12/24	
Pressure angle		30°	
Pitch diameter	D	25.4	[1.0]
Major diameter	D_{ri}	$28.0_{-0.1}^0$	[$1.10_{-0.004}^0$]
Form diameter (min.)	D_{fi}	27.6	[1.09]
Minor diameter	D_i	$23.0_{+0.033}^0$	[$0.9055_{+0.0013}^0$]
Space width (circular)	L_o	4.308 ± 0.020	[0.1696 ± 0.0008]
Tooth thickness (circular)	S_o	2.341	[0.09217]
Fillet radius	R_{min}	0.2	[0.008]
Maximum measurement between pins	l	$17.62_{+0.15}^0$	[$0.700_{-0.006}^0$]
Pin diameter	d	4.835 ± 0.001	[0.1903 ± 0.00004]

Table 40 Internal involute spline data

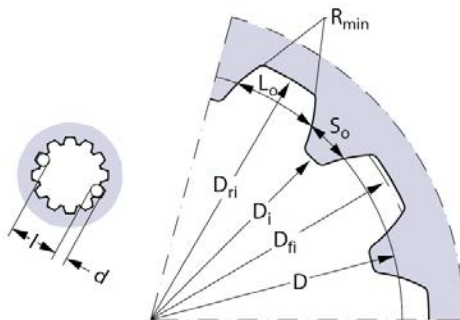

Figure 33 Finished dimensions (when hardened).

Internal involute spline data

 Standard ANSI B92.1-1996, class 5 (corrected $m \cdot X = 0.8$; $m = 2.1166$)

WHITE can accept no responsibility for possible errors in catalogues, brochures, and other printed material. WHITE reserves the right to alter its products without notice. This also applies to products already on order provided that such alterations can be made without subsequent changes being necessary in specifications already agreed.

All trademarks in this material are the property of the respective companies. WHITE and the WHITE logotype are trademarks of WHITE Drive Motors & Steering LLC and WHITE Drive Motors and Steering Sp. z o.o..

All rights reserved.

Archivierung: 11/2025

Motor or attached component drain connection

Use the drain line when pressure in the return line exceeds the permissible pressure on the shaft seal of the attached component.

Connect the drain line either at the:

- Motor drain connection
- Drain connection of the attached component

If a drain line is fitted to the attached component, it must be possible for oil to flow freely between motor and attached component.

The drain line must be led to the tank in such a way that there is no risk of the motor and attached component being drained of oil when at rest.

The maximum pressure in the drain line is limited by the attached component and its shaft seal.

Tables

Table 1 Mounting flange: Standard 4 hole flange	9
Table 2 Code numbers: OMS Standard 4 hole flange	9
Table 3 Mounting flange: Special 4 hole flange	9
Table 4 Code numbers: OMS Special 4 hole flange	10
Table 5 Mounting flange: A2 flange.....	10
Table 6 Code numbers: OMS A2 flange	10
Table 7 Mounting flange: Magneto flange	10
Table 8 Code numbers: OMS Magneto flange.....	11
Table 9 Mounting flange: SAE B flange.....	11
Table 10 Code numbers: OMS SAE B flange	11
Table 11 Mounting flange: Wheel EU	11
Table 12 Code numbers: Wheel (EU).....	11
Table 13 Mounting flange: Wheel US	12
Table 14 Code numbers: Wheel (US).....	12
Table 15 Mounting flange: Short	12
Table 16 Code numbers: Short	12
Table 17 OMS, OMSW, OMSS technical data	14
Table 18 Maximum pressures.....	15
Table 19 Maximum torque for OMS shaft type.....	15
Table 20 Oil flow in drain line	16
Table 21 Shaft versions	31
Table 22 Port thread versions.....	31
Table 23 Standard flange EU version	33
Table 24 Output shaft	34
Table 25 Special flange EU version	35
Table 26 Wheel EU version	36
Table 27 Short EU version	37
Table 28 Standard US version	38
Table 29 Output shaft US version	39
Table 30 A2 flange US version	40
Table 31 Output shaft US version	40
Table 32 Magneto flange US version	41
Table 33 Output shaft US version	42
Table 34 SAE B flange US version.....	43
Table 35 Output shaft US version	43
Table 36 Wheel US version	44
Table 37 Output shaft US version	45
Table 38 Wheel US version	46
Table 39 Output shaft US version	46
Table 40 Internal involute spline data; Standard ANSI B92.1-1996, class 5 (corrected $m \cdot X = 0.8$; $m = 2.1166$)	49

Figures

Figure 1 Maximum speed	6
Figure 2 Maximum torque	7
Figure 3 Maximum output	7
Figure 4 OMS with check valves without drain connection.....	15
Figure 5 Maximum return pressure without drain line or maximum pressure in the drain line.....	16
Figure 6 Pressure Drop in OMSW	16

WHITE can accept no responsibility for possible errors in catalogues, brochures, and other printed material. WHITE reserves the right to alter its products without notice. This also applies to products already on order provided that such alterations can be made without subsequent changes being necessary in specifications already agreed.

All trademarks in this material are the property of the respective companies. WHITE and the WHITE logotype are trademarks of WHITE Drive Motors & Steering LLC and WHITE Drive Motors & Steering SP. z o.o..

All rights reserved.

Archivierung: 11/2025

Figure 7 direction of shaft rotation.....	17
Figure 8 OMS Mounting flange: Standard, A2, Magneto, SAE B.....	18
Figure 9 OMS Mounting flange: Wheel	18
Figure 10 OMS Mounting flange: special.....	19
Figure 11 Mounting flange: A2-Magneto	19
Figure 12 Mounting flange: SAE B	20
Figure 13 OMS 80 function diagram	22
Figure 14 OMS 100 function diagram	22
Figure 15 OMS 125 function diagram	23
Figure 16 OMS 160 function diagram	23
Figure 17 OMS 200 function diagram	24
Figure 18 OMS 250 function diagram	24
Figure 19 OMS 315 function diagram	25
Figure 20 OMS 400 function diagram	25
Figure 21 OMS 500 function diagram	26
Figure 22 Standard flange EU version.....	33
Figure 23 Special flange - EU version.....	35
Figure 24 Wheel - EU version.....	36
Figure 25 Short EU version	37
Figure 26 Standard flange US version	38
Figure 27 A2 flange US version	39
Figure 28 Magneto flange.....	41
Figure 29 SAE B flange US version	42
Figure 30 Wheel US version.....	44
Figure 31 OMSS US version.....	45
Figure 32 OMSS dimensions of the attached component	48
Figure 33 Finished dimensions (when hardened).....	49

WHITE can accept no responsibility for possible errors in catalogues, brochures, and other printed material. WHITE reserves the right to alter its products without notice. This also applies to products already on order provided that such alterations can be made without subsequent changes being necessary in specifications already agreed.

All trademarks in this material are the property of the respective companies. WHITE and the WHITE logotype are trademarks of WHITE Drive Motors & Steering LLC and WHITE Drive Motors & Steering SP. z o.o..

All rights reserved.

Archivierung: 11/2025



White Drive Motors & Steering, LLC
110 Bill Bryan Blvd, Hopkinsville, Kentucky, 42240

White Drive Motors and Steering sp. z o.o.
ul. Logistyczna 1, Bielany Wrocławskie, 55-040 Kobierzyce

whitedriveproducts.com