

HYDAC INTERNATIONAL



DF / DFF Pressure filter / pressure filter for reversible oil flow

Symbol for hydraulic systems:

DF

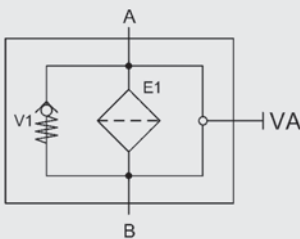



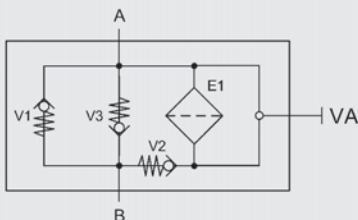















DFF



- A Inlet
- B Outlet
- E1 Filter element
- V1 Bypass valve
- V2 Check valve
- V3 Check valve

1. SIZES

DF/DFF...1.X/2.X											DF...3.X							
30	60	110	140	160	240	280	330	500	660	990	1320	1500	330	500	660	990	1320	1500
																		

2. TECHNICAL DATA

Filter characteristics

Nominal pressure	420 bar
Maximum flow rate	960 l/min
Temperature range	-30 °C to + 100 °C (-30 °C to -10 °C: max. 210 bar)

Filter head material EN-GJS 400-15

Filter bowl material Steel

Clogging indicator

Type	VD
Response pressure	5.0 bar (DFF: 8.0 bar)

Bypass (optional)

Cracking pressure	6.0 bar
-------------------	---------

Other

Seals	NBR (= Perbunan)
Installation	As inline filter with or without reversible oil flow
Spare parts and accessories	<ul style="list-style-type: none"> ■ FKM seals ■ With bypass valve (except for DFF 1500) ■ Element removable from above – type code: 3.X (only DF filter 330-1320)
Spare parts	See original spare parts list
Certificates and approvals	On request

3. GENERAL DESCRIPTION

3.1 FILTER HOUSING

Design

The filter housings are designed in accordance with international regulations. They consist of a filter head that the filter bowl is screwed into. The DFF filters are suitable for both directions of flow. Filtration in just one direction (see symbol for hydraulic systems).

Series design

- Hole for clogging indicator in filter head
- Without bypass valve
- Drain plug with pressure release (DF/DFF 330 and above)
- Choice of 1- or 2-piece filter bowl for DF/DFF 660
- 2-piece filter bowl for DF/DFF 990 and above

3.2 FILTER ELEMENTS

The HYDAC filter elements are validated according to the following standards and their quality is constantly monitored: ISO 2941, ISO 2942, ISO 2943, ISO 3724, ISO 3968, ISO 11170, ISO 16889.

Collapse pressure strengths

Designation	Model code	Collapse pressure
SUSTAINMICRON®	SN	20 bar
Betamicon®	BH4HC	170 bar
Stainless steel wire mesh	W, W/HC	20 bar

3.3 FATIGUE STRENGTH

The fatigue strength is:

- DF 30-1320: 2,000,000 load reversals at nominal pressure
- DF 1500: 3,000,000 load reversals at 280 bar
300,000 load reversals at 420 bar

3.4 COMPATIBILITY WITH PRESSURISED FLUIDS (ISO 2943)

- Hydraulic oils HL to HVLP (DIN 51524)
- Lubrication oils (DIN 51517, API, ACEA, DIN 51515, ISO 6743)
- Compressor oils (DIN 51506)
- Readily biodegradable hydraulic fluids HETG, HEES, HEPG (VDMA 24568) only possible with FKM seal
- Flame-retardant hydraulic fluids HFA, HFB, HFC and HFD (ISO 12922) and fluids with high water content on request (>50% water) on request

3.5 WARNINGS

- The filter housings must be earthed, for example via the system/pipework.
- If electrical clogging indicators are used, the system must be de-energised before removing the clogging indicator connector.

4. MODEL CODE

4.1 FILTER ASSEMBLY

DF SN 1500 T L L 10 D 1 . X /-L24

Filter type

DF, DFF

Filter material

SN SUSTAINMICRON®

BH/HC Betamicron®

W stainless steel wire mesh (not possible for version 2.X)

W/HC stainless steel wire mesh

Size of filter

30, 60, 110, 140, 160, 240, 280, 330, 500, 660, 990, 1320, 1500

Operating pressure

T 420 bar

Head form

Omitted inline filter design

L flow in L form (only DF/DFF 1500)

Connection type/size

Type	Connection	Filter size													
		30	60	110	140	160	240	280	330	500	660	990	1320	1500	
B	G ½	•													
C	G ¾		•	•	•										
E	G 1 ¼					•	•	•							
F	G 1 ½								•	•	•	•	•		
G	G 2													•	
I	SAE DN 20		•	•	•										
J	SAE DN 32					•	•	•							
L	SAE DN 50								•	•	•	•	•	•	•

Filtration rating in µm

SN 003, 005, 010, 020

BH/HC 003, 005, 010, 020

W 025, 050, 100, 200

W/HC 025, 050, 100, 200

Clogging indicator design

A Hole sealed with locking screw

B Visual

BM Visual indicator display with red pin for manual reset

C Electric

D Visual and electric

LE Visual indicator, electrical switch at 100% of response pressure

LZ Visual indicator, electrical switch at 75% and 100% of response pressure

Type code

1 One-piece filter bowl (up to DF/DFF 660)

2 Two-piece filter bowl (DF/DFF 660 and above)

3 Element removable from above (DF/DFF 330-1320)

Change number

X The latest version of the specific type is always supplied

Supplementary details

V FKM seal, omitted = NBR seal

A. Response pressure (e.g.: A2 = 2 bar), omitted = 5 bar (DF), 8 bar (DFF)

B. Bypass cracking pressure (e.g.: B6 = 6 bar), omitted = without bypass valve (bypass not possible for DFF 1500)

SO184 Pressure unloading plug / drain plug (for DF/DFF 330 series and above)

W Suitable for oil-in-water emulsions HFA, HFC (only necessary for use of a clogging indicator, or V or W elements)

L... Lamp with corresponding voltage (24V, 48V, 110V, 220V) (CI design: D)

LED Two LEDs up to 24-volt voltage (CI design: D)

SO135 For low current (PLC control, ATEX)

DB Connector in acc. with Daimler-Benz (CI design: LZ)

AV Connector in acc. with Audi, VW (CI design: LZ)

BO Connector in acc. with BMW, Opel, Ford (CI design: LZ)

4.2 SPARE ELEMENT
0067 D 010 SN /-V
Size

0030, 0067, 0117, 0147, 0167, 0247, 0287, 0330, 0337, 0500, 0507, 0660, 0667, 0990, 0997, 1320, 1327, 1500

Version

D

Filtration rating in μm

SN 003, 005, 010, 020

BH4HC 003, 005, 010, 020

W 025, 050, 100, 200

W/HC 025, 050, 100, 200

Filter material

SN, BH4HC, W, W/HC

Supplementary details

V, W (for descriptions, see section 4.1)

4.3 CLOGGING INDICATOR
VD 5 D . X /-L24
Type

VD Differential pressure measurement up to 420 bar operating pressure

Response pressure

5 Standard for DF filter: 5 bar

8 Standard for DFF filter: 8 bar

Version

D See section 4.1

Change number

X The latest version of the specific type is always supplied

Supplementary details

L..., LED, V, W (for descriptions, see section 4.1)

5. FILTER CALCULATION

The total pressure loss of a filter at a certain **volume flow Q** and a **viscosity ν** consists of the sum of the **housing pressure loss $\Delta p_{\text{housing}}$** and the **element differential pressure $\Delta p_{\text{element}}$** and is calculated as follows:

$$\Delta p_{\text{total}} = \Delta p_{\text{total}} + \Delta p_{\text{element}}$$

$$\Delta p_{\text{housing}} \text{ [bar]} = \text{see performance curves}$$

$$\Delta p_{\text{element}} \text{ [bar]} = Q \text{ [l/min]} \cdot \frac{SK \text{ [mbar / (l/min)]}}{1000} \cdot \frac{\nu \text{ [mm}^2\text{/s]}}{30}$$

SK = slope coefficient (see section 5.2)

For straightforward filter dimensioning without having to perform any calculations yourself, use our free-of-charge filter dimensioning program available at:

www.hydac.com/de-de/service/online-tools

5.1 HOUSING PERFORMANCE CURVES

The housing performance curves were determined on the basis of ISO 3968. They apply to mineral oil with a density of 0.86 kg/dm³ and a kinematic viscosity of 30 mm²/s. The differential pressure changes proportionally to the density.

DF 30

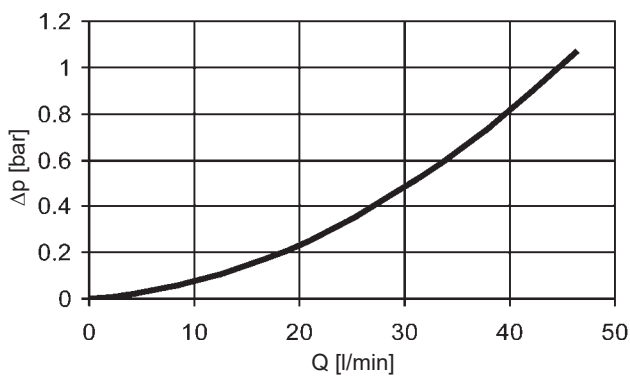

DF 60, 110, 140

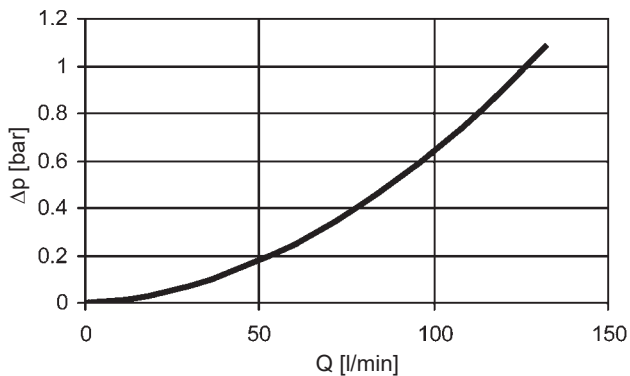

DFF 60, 110, 140

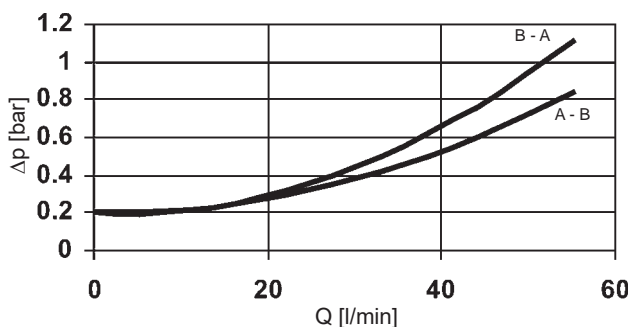

DF 160, 240, 280

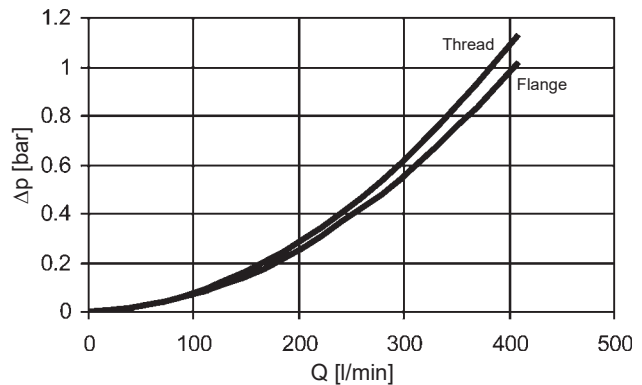

DFF 160, 240, 280

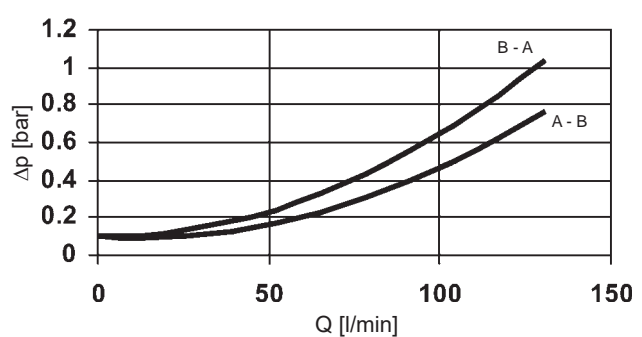

DF 330, 500, 660, 990, 1320

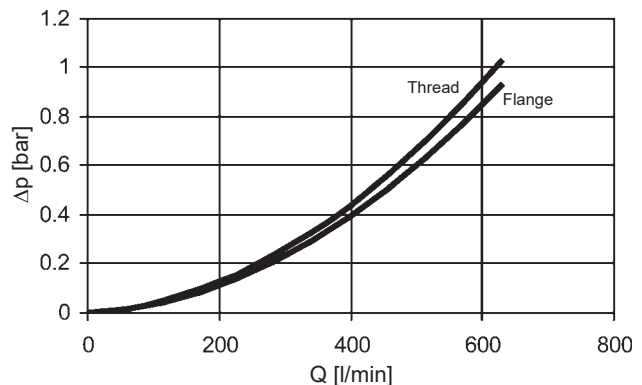

DFF 330, 500, 660, 990, 1320

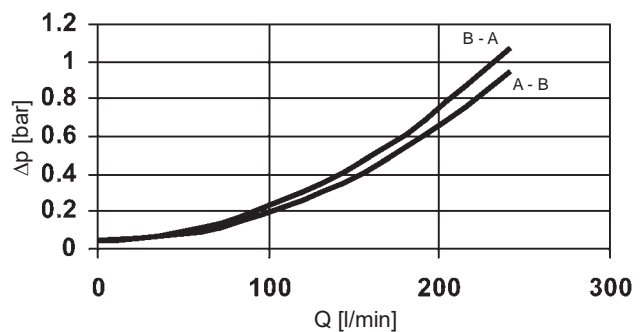

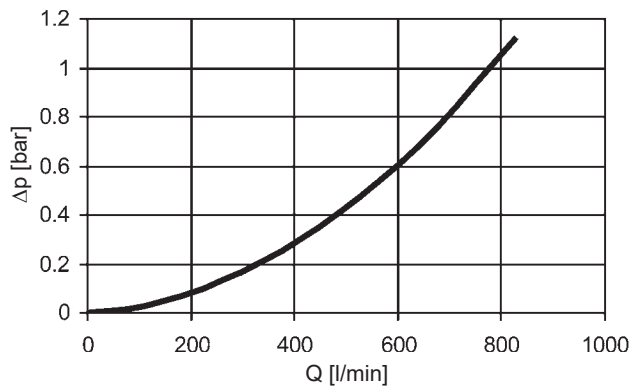
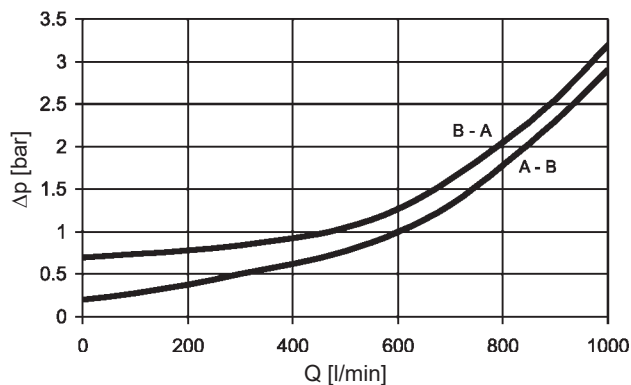
DF 1500

DFF 1500

5.2 SLOPE COEFFICIENTS (SK)

The slope coefficients in mbar/(l/min) apply to mineral oils with a kinematic viscosity of 30 mm²/s. The pressure loss changes in proportion to the change in the viscosity.

Size	SN			
	3 μm	5 μm	10 μm	20 μm
0030	49.705	33.136	16.178	11.300
0067	23.913	16.470	10.285	5.535
0117	11.318	8.649	5.151	2.620
0147	8.423	6.651	3.723	1.950
0167	7.890	6.930	3.198	2.776
0247	5.022	4.272	2.664	1.887
0287	2.556	2.192	1.162	1.066
0330	3.496	3.033	1.968	1.035
0337	3.496	3.033	1.968	1.035
0500	2.138	1.863	0.984	0.633
0507	2.138	1.863	0.984	0.633
0660	1.600	1.404	0.744	0.474
0667	1.600	1.404	0.744	0.474
0990	1.065	0.928	0.490	0.315
0997	1.065	0.928	0.490	0.315
1320	0.784	0.683	0.361	0.232
1327	0.784	0.683	0.361	0.232
1500	0.791	0.651	0.407	0.245

Size	BH4HC			
	3 μm	5 μm	10 μm	20 μm
0030	91.2	50.7	36.3	19.0
0067	58.6	32.6	18.1	12.2
0117	25.4	14.9	8.9	5.6
0147	19.9	11.3	8.1	4.3
0167	16.8	10.4	5.9	4.4
0247	10.6	6.8	3.9	2.9
0287	5.7	3.4	1.8	1.6
0330	7.7	4.5	2.8	2.0
0337	7.7	4.5	2.8	2.0
0500	4.2	2.6	1.5	1.2
0507	4.2	2.6	1.5	1.2
0660	3.3	1.9	1.0	0.9
0667	3.3	1.9	1.0	0.9
0990	2.2	1.3	0.8	0.6
0997	2.2	1.3	0.8	0.6
1320	1.6	1.0	0.6	0.4
1327	1.6	1.0	0.6	0.4
1500	1.4	0.8	0.6	0.5

Size	W	W/HC
0030	3.030	-
0067	0.757	0.757
0117	0.413	0.413
0147	0.324	0.324
0167	0.284	0.284
0247	0.189	0.189
0287	0.162	0.162
0330	0.138	0.138
0337	0.138	0.138
0500	0.091	0.091
0507	0.091	0.091
0660	0.069	0.069
0667	0.069	0.069
0990	0.046	0.046
0997	0.046	0.046
1320	0.035	0.035
1327	0.035	0.035
1500	0.020	-

5.3 MAXIMUM FLOW RATE

For the different unit sizes and connections sizes, the following maximum permitted flow rates (Q_{\max}) apply for DF filters (DFF filters on request):

Size	Connection	Q_{\max} [l/min]
30	B	30
60	C, I	80
110	C, I	110
140	C, I	120
160	E, J	260
240	E, J	280
280	E, J	360
330	F	380
330	L	450
500	F	460
500	L	570
660	F	500
660	L	610
990	F	520
990	L	660
1320	F	540
1320	L	680
1500	G, L	877
1500	G, L (L flow)	960

Design note:

The hydraulic load on the filter element is essentially defined by the volume flow and the respective filter element geometry. Exceeding the maximum permissible peak volume flow (Q_{\max}) and thus the permissible hydraulic load can lead to the destruction of the filter element.

The choice of operating medium can also affect system performance and lead to application problems such as electrostatic discharges.

Compliance with the permissible volume flow should always be ensured during system planning.

If you have any questions regarding design and project planning, please contact HYDAC Filbertechnik's technical sales department.

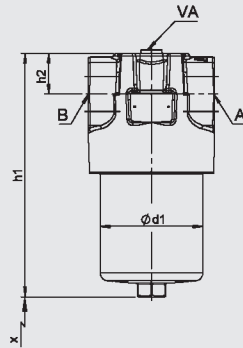
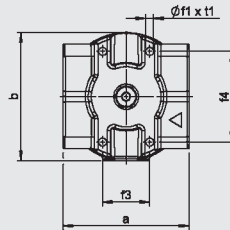
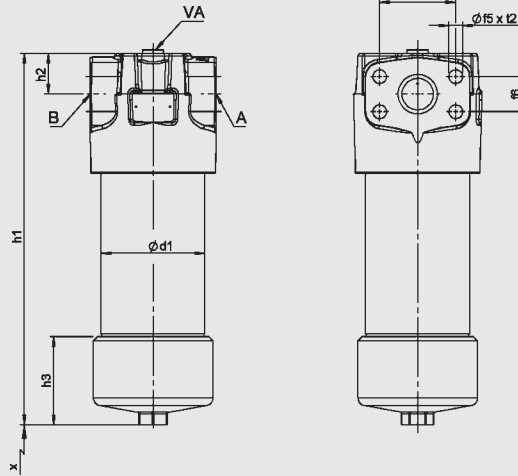
6. DIMENSIONS
DF 30, DF/DF 60 - 1500
Variant 1.X

Variant 2.X

VA = clogging indicator

Size	a	b	$\phi d1$	$\phi f1$	f3	f4	$\phi f5$	f6	f7	h1	h2	h3	SW	t1	t2	x	Weight with element [kg]	Pressure chamber capacity [l]	
30... B...	1.X	68	69	52	M5	30	45	-	-	-	168.5	38	-	24	6	-	75	2.3	0.13
60... C...	1.X	90	86	68	M6	32	56	-	-	-	184	40	-	27	9	-	85	4.5	0.2
60... I...	1.X	89	86	68	M6	32	56	M10	23.8	50.8	184	40	-	27	9	15	85	4.5	0.2
110... C...	1.X	90	86	68	M6	32	56	-	-	-	253.5	40	-	27	9	-	85	5.4	0.33
110... I...	1.X	89	86	68	M6	32	56	M10	23.8	50.8	253.5	40	-	27	9	15	85	5.4	0.33
140... C...	1.X	90	86	68	M6	32	56	-	-	-	294.5	40	-	27	9	-	85	6	0.4
140... I...	1.X	89	86	68	M6	32	56	M10	23.8	50.8	294.5	40	-	27	9	15	85	6	0.4
160... E...	1.X	125	119	95	M10	35	85	-	-	-	244	47	-	32	14	-	105	10.3	0.6
160... J...	1.X	125	119	95	M10	35	85	M14	31.8	66.7	244	47	-	32	14	19	105	10.3	0.6
240... E...	1.X	125	119	95	M10	35	85	-	-	-	303	47	-	32	14	-	105	11.8	0.8
240... J...	1.X	125	119	95	M10	35	85	M14	31.8	66.7	303	47	-	32	14	19	105	11.8	0.8
280... E...	1.X	125	119	95	M10	35	85	-	-	-	485	47	-	32	14	-	105	16.3	1.6
280... J...	1.X	125	119	95	M10	35	85	M14	31.8	66.7	485	47	-	32	14	19	105	16.3	1.6
330... F...	1.X	160	163	130	M12	60	115	-	-	-	309.5	52	-	36	17	-	115	24.5	1.5
330... L...	1.X	160	163	130	M12	60	115	M20	44.5	96.8	309.5	52	-	36	17	25	115	24.5	1.5
500... F...	1.X	160	163	130	M12	60	115	-	-	-	409.5	52	-	36	17	-	115	28.6	2.3
500... L...	1.X	160	163	130	M12	60	115	M20	44.5	96.8	409.5	52	-	36	17	25	115	28.6	2.3
660... F...	1.X	160	163	130	M12	60	115	-	-	-	479	52	-	36	17	-	115	31.6	3
660... L...	1.X	160	163	130	M12	60	115	M20	44.5	96.8	479	52	-	36	17	25	115	31.6	3
330... F...	2.X	160	163	132	M12	60	115	-	-	-	306	52	112	36	17	-	180	27.4	1.5
330... L...	2.X	160	163	132	M12	60	115	M20	44.5	96.8	306	52	112	36	17	25	180	27.4	1.5
500... F...	2.X	160	163	132	M12	60	115	-	-	-	395	52	112	36	17	-	270	31.5	2.3
500... L...	2.X	160	163	132	M12	60	115	M20	44.5	96.8	395	52	112	36	17	25	270	31.5	2.3
660... F...	2.X	160	163	132	M12	60	115	-	-	-	472	52	112	36	17	-	350	34.4	3
660... L...	2.X	160	163	132	M12	60	115	M20	44.5	96.8	472	52	112	36	17	25	350	34.4	3
990... F...	2.X	160	163	132	M12	60	115	-	-	-	628	52	112	36	17	-	500	43.4	4.2
990... L...	2.X	160	163	132	M12	60	115	M20	44.5	96.8	628	52	112	36	17	25	500	43.4	4.2
1320... F...	2.X	160	163	132	M12	60	115	-	-	-	794	52	112	36	17	-	670	51.1	5.6
1320... L...	2.X	160	163	132	M12	60	115	M20	44.5	96.8	794	52	112	36	17	25	670	51.1	5.6
1500... G...	2.X	196	176	152	M12	54	110	-	-	-	884.5	60	122	36	22	-	700	69.3	8.2
1500... L...	2.X	196	176	152	M12	54	110	M20	44.5	96.8	884.5	60	122	36	22	30	700	69.3	8.2

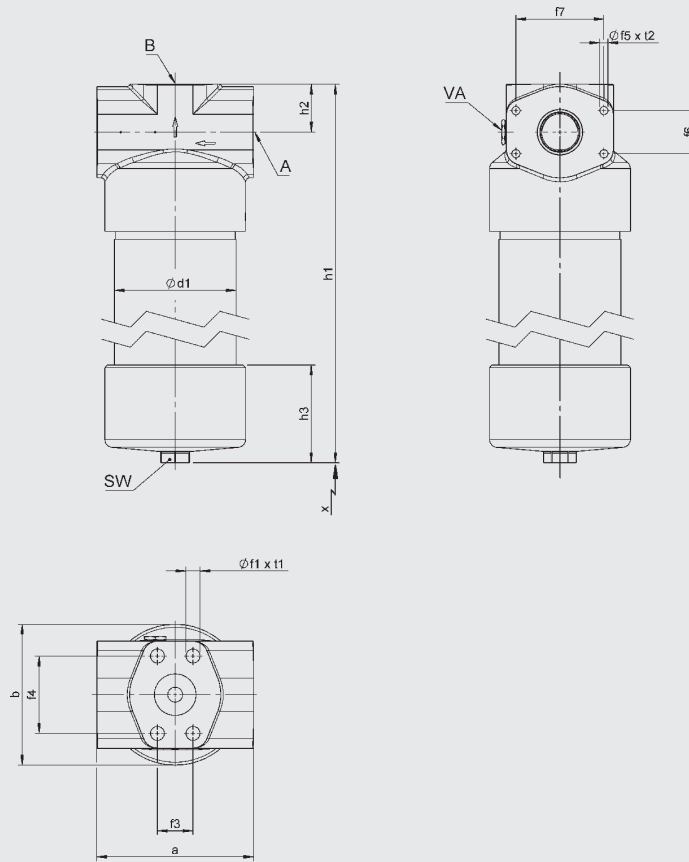
 B, C, E, F, G = thread connection
 I, J, L = flange connection in acc. with DIN ISO 6162, 6000 psi with metric thread

DF 1500 (flow in L form)

VA = clogging indicator
SW = spanner width

Size	a	b	Ød1	Øf1	f3	f4	Øf5	f6	f7	h1	h2	h3	SW	t1	t2	x	Weight with element [kg]	Pressure chamber capacity [l]
1500... TLG... 2.X																		
1500... TLL... 2.X	196	176	152	M12	54	110	M20	54	110	888.5	60	122	36	22	30		69.3	8.2

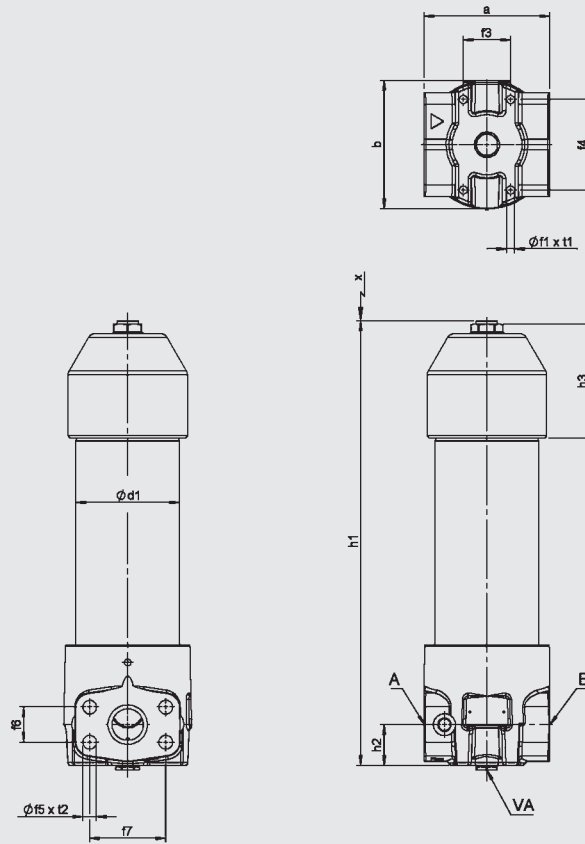
DF 330 - 1320...3.X (removable from above)

VA = clogging indicator

Size		a	b	Ød1	Øf1	f3	f4	Øf5	f6	f7	h1	h2	h3	SW	t1	t2	x	Weight with element	Pressure chamber capacity	
																		[kg]	[l]	
330...	F...	3.X	160	163	132	M12	60	115	-	-	366	52	149	36	17	25	80	27.9	1.5	
330...	L...	3.X	160	163	132	M12	60	115	M20	44.5	96.8	366	52	149	36	17	25	80	27.9	1.5
500...	F...	3.X	160	163	132	M12	60	115	-	-	455	52	149	36	17	25	170	31.8	2.3	
500...	L...	3.X	160	163	132	M12	60	115	M20	44.5	96.8	455	52	149	36	17	25	170	31.8	2.3
660...	F...	3.X	160	163	132	M12	60	115	-	-	532	52	149	36	17	25	250	33.9	3	
660...	L...	3.X	160	163	132	M12	60	115	M20	44.5	96.8	532	52	149	36	17	25	250	33.9	3
990...	F...	3.X	160	163	132	M12	60	115	-	-	687	52	149	36	17	25	400	43.1	4.2	
990...	L...	3.X	160	163	132	M12	60	115	M20	44.5	96.8	687	52	149	36	17	25	400	43.1	4.2
1320...	F...	3.X	160	163	132	M12	60	115	-	-	853	52	149	36	17	25	570	50.8	5.6	
1320...	L...	3.X	160	163	132	M12	60	115	M20	44.5	96.8	853	52	149	36	17	25	570	50.8	5.6
1500...	L...	3.X	196	176	152.4	M12	54	110	M20	44.5	96.8	930.5	60	124	36	22	30	700	65	8.2

7. MAINTENANCE

7.1 MAINTENANCE

General

Please observe the maintenance notices!

Tools required for maintenance

Size	Key for filter bowl	Hexagon socket key for drain plug	Key for VD 0 A.1
30	SW 24	SW 6*	SW 27
60-140	SW 27	SW 10*	SW 27
160-280	SW 32	SW 10*	SW 27
330-1500	SW 36	SW 10	SW 27

*For SO184

Tightening torques for clogging indicators

Type	Max. torque
VD	100 Nm (B, C, D) 50 Nm (A, LE, LZ)

Installation:

Before the filter is installed in the system, it must be checked whether the system's operating pressure is higher than the permitted operating pressure of the filter.

Refer to the type label on the filter!

Important:

If filters are used without a bypass valve and operating pressures above 20 bar, filter elements with high differential pressure stability of the type BH4HC, OH/PS should be used for safety reasons

Startup:

Check that the intended filter element has been inserted correctly, screw the bowl back in fully and then unscrew it by one quarter-turn (fastening the bowl any tighter does not improve the sealing effect!).

Switch on the hydraulic system and check filter for leakage.

Vent filter at a suitable point in the system.

Under extreme conditions (e.g. cold start), bypass valves enable a brief sub-flow to pass at the element.

7.2 ELEMENT CHANGE

Element removal:

- Switch off hydraulic system and release filter pressure.
- Remove drain plug (if present).
Collect oil in container.
- One-piece bowl (1.X):
Unscrew filter bowl (drain fluid into a suitable container and clean or dispose of it in accordance with environmental regulations).
Two-piece bowl (2.X):
Unscrew and remove bowl end cap (drain fluid into a suitable container and clean or dispose of it in accordance with environmental regulations) and remove grub screw.
Removable from above (3.X):
Unscrew and remove end cap.
- Remove the filter element from the spigot in the filter head (check the surface of the filter element for contamination residue and larger particles; these can indicate damage to components).
- Clean or replace the filter element (only W and V elements can be cleaned).
- Clean filter bowl and filter head; particular attention must be given to the threads!
- Examine filter, especially sealing surfaces, for mechanical damage.
- Check O-rings – replace parts if necessary.

Element installation:

- Wet sealing surfaces and thread on filter head and bowl / bowl cap and on O-ring with clean operating fluid.
- Before fitting a new filter element, check that the designation corresponds to that of the old element.
- Place filter element carefully onto the element spigot. Additionally for two-piece bowl (2.X):
Fix with grub screw.
- One-piece bowl (1.X):
Screw on the filter bowl fully to the stop.
Two-piece bowl (2.X) and removable from above (3.X):
Screw in bowl end cap fully to the stop.
- Screw in drain plug (if present).
- Unscrew filter bowl / bowl end cap by one quarter-turn.
- Switch on hydraulic system and vent filter at a suitable point in the system.
- Check the filter for leakage.

Notice:

Contamination or incomplete pressure release on disassembly can lead to seizing of the bowl screw-in thread.

Filter elements that cannot be cleaned must be disposed of in accordance with environment protection regulations.

8. SPARE PARTS

8.1 SPARE PARTS DRAWING DF 30 – 660; DFF 60 – 660; 1.X (one-piece bowl); DF removable from above 330 – 660 ... 3.X

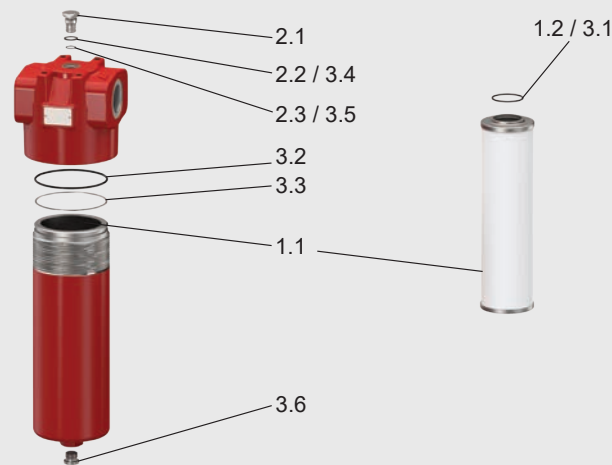

8.2 SPARE PARTS DRAWING DF 30 – 660; DFF 60 – 660; 1.X (one-piece bowl); DF removable from above 330 – 660 ... 3.X

Item	Contains	Designation of filter assembly	30	60	110	140	160	240
1.		Filter element	See item 9. Spare elements					
	1.1	Filter element	0030 D...	0067 D...	0117 D...	0147 D...	0167 D...	0247 D...
	1.2	O-ring	12.37 x 2.62	22 x 3	22 x 3	22 x 3	34 x 3	34 x 3
2.		Clogging indicator or locking screw	See item 10. Spare clogging indicator					
	2.1	Locking screw VD 0 A.1 / VD 0 A.1 /-V	00305932 / 00305931					
	2.2	Profile seal ring	VM...					
	2.3	O-ring	15 x 1.5					
3.		Repair kit DF	00305791		01260990			00305264
		Repair kit DF /-V	00305792		00302094			00304037
	3.1	O-ring (element)	12.37 x 2.62		22 x 3			34 x 3
	3.2	O-ring (bowl)	46 x 3		59 x 3			80 x 4
	3.3	Support ring (bowl)	DF...30		DF...60			DF...160
	3.4	Profile seal ring (indicator)	VM...		VM...			VM...
	3.5	O-ring (indicator)	15 x 1.5		15 x 1.5			15 x 1.5
	3.6*	Drain plug	G 1/4		G 1/2			G 1/2

Item	Contains	Designation of filter assembly	280	330	500	660
1.		Filter element	See item 9. Spare elements			
	1.1	Filter element	0287 D...	0330 D...; 0337 D...	0500 D...; 0507 D...	0660 D...; 0667 D...
	1.2	O-ring	34 x 3	48 x 3	48 x 3	48 x 3
2.		Clogging indicator or locking screw	See item 10. Spare clogging indicator			
	2.1	Locking screw VD 0 A.1 / VD 0 A.1 /-V	00305932 / 00305931			
	2.2	Profile seal ring	VM...			
	2.3	O-ring	15 x 1.5			
3.		Repair kit DF	00305264		00302270	
		Repair kit DF /-V	00304037		00302271	
	3.1	O-ring (element)	34 x 3		48 x 3	
	3.2	O-ring (bowl)	80 x 4		117 x 4	
	3.3	Support ring (bowl)	DF...160		DF...330	
	3.4	Profile seal ring (indicator)	VM...		VM...	
	3.5	O-ring (indicator)	15 x 1.5		15 x 1.5	
3.6*	Drain plug	G 1/2		G 1/2		

* Where applicable
Other spare parts on request

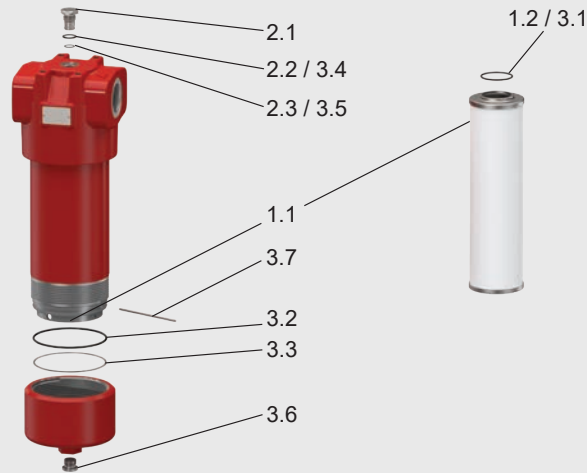
**8.3 SPARE PARTS DRAWING DF 330 – 1500; DFF 330 – 1500; 2.X (two-piece bowl);
DF removable from above 330 – 1320 ... 3.X**

8.4 SPARE PARTS DRAWING DF 330 – 1500; DFF 330 – 1500; 2.X (two-piece bowl); DF removable from above 330 – 1320 ... 3.X

Item	Contains	Designation of the filter assembly	660	990	1320	1500
1.		Filter element	See item 9. Spare elements			
	1.1	Filter element	0660 D...; 0667 D...	0990 D...; 0997 D...	1320 D...; 1327 D...	1500 D...
	1.2	O-ring	48 x 3	48 x 3	48 x 3	59.92 x 3.53
2.		Clogging indicator or locking screw	See item 10. Spare clogging indicator			
	2.1	Locking screw VD 0 A.1 / VD 0 A.1 /-V	00305932 / 00305931			
	2.2	Profile seal ring	VM...			
	2.3	O-ring	15 x 1.5			
3.		Repair kit DF Repair kit DF /-V		01263575 01263576		01289468 01290014
	3.1	O-ring (element)		48 x 3		59.92 x 3.53
	3.2	O-ring (bowl)		117 x 4		132.72 x 5.33
	3.3	Support ring (bowl)		DF...330		DF..1000
	3.4	Profile seal ring (indicator)		VM...		VM...
	3.5	O-ring (indicator)		15 x 1.5		15 x 1.5
	3.6	Drain plug		G 1/2		G 1/2
	3.7	Threaded pin		M4 x 120		M4 x 135

9. SPARE ELEMENT
0067 D 010 SN /-V
Size

 0030, 0067, 0117, 0147, 0167, 0247, 0287,
0330, 0337, 0500, 0507, 0660, 0667,
0990, 0997, 1320, 1327, 1500

Design

D

Filtration rating

 SN 003, 005, 010, 020
BH4HC: 003, 005, 010, 020
W, W/HC: 025, 050, 100, 200

Filter material

SN, BH4HC, W, W/HC

Supplementary details

V, W (for description, see brochure "DF")

10. SPARE CLOGGING INDICATOR
VD 5 D X /-L24
Type of indicator

 VD Differential pressure measurement
Up to 420 bar operating pressure

Response pressure

 5 Standard for DF filters: 5 bar*
8 Standard for DFF filters: 8 bar*

Clogging indicator version

 A Hole sealed with locking screw
B Visual
C Electric
D Visual and electric

Modification number

 X The latest version of the specific
type is always supplied

Supplementary details

 L..., LED, V, W
(For description, see "Clogging indicators" brochure)

* Others on request

11. MAINTENANCE INSTRUCTIONS

11.1 EXPLANATION OF SYMBOLS AND NOTES

This type of safety sign or instruction ...



Danger

indicates a dangerous situation which, if not avoided, will result in death or serious injury.



Warning

indicates a situation that could lead to death or serious injury, or serious harm to health, if it is not avoided.



Info

shows labelling for proper handling of the pressure equipment. Failure to observe these notices may lead to damage to the elements or their immediate surroundings.



Waste disposal

shows labelling of special measures for environmental protection. Proper and environmentally friendly disposal of the material.



Notice

indicates labelling of special user tips and other particularly useful or important information.

11.2 GENERAL MAINTENANCE

This section describes maintenance work to be carried out periodically. The operational readiness, operational safety and service life of the filter depend to a large extent on regular and careful maintenance.



Notice

For each filter used, original filter elements must be kept in stock and replaced if necessary.

11.3 FUNDAMENTALS AND BASICS

This document is intended to provide information and prevent hazards during installation, operation of the system and handling of operating materials.

Safe and economical operation of the system is only possible if the installation instructions are strictly observed.

These installation instructions are not a substitute for the operating instructions for the machine or system.

The individual installation instructions for the installed components of the overall system also apply.

11.4 QUALIFICATIONS OF PERSONNEL / TARGET GROUP

These installation instructions are intended exclusively for use by trained specialist personnel¹ and must be kept accessible at the place of use.

11.5 INTENDED USE

The filter is only suitable for filtering hydraulic fluids.

The filter is not usable on its own. The filter is intended for installation in a hydraulic system.

Any other use or use beyond this is considered improper use. HYDAC Filtertechnik GmbH is not liable for any resulting damage.

11.6 MAINTENANCE MEASURES

- The spare parts have to satisfy the manufacturer's technical specifications. This is always ensured if HYDAC original parts are used.
- Keep tools, work area and devices clean.
- After dismantling the filter, clean all parts, check for damage or wear and replace parts if necessary.
- Ensure maximum cleanliness when replacing a filter element!

11.7 USER INSTRUCTIONS FOR FILTERS



Danger

Caution Filter is pressurised: when carrying out any work on the filter, ensure that the relevant pressure chamber (filter housing) is depressurised.

No modifications (welding, drilling, forcible opening, etc.) may be made to the filter.

Filter housings must be earthed.

When working on, or in the vicinity of, hydraulic systems, the use of naked flames, spark generation and smoking are forbidden.

Hydraulic oil and water-polluting fluids must not be allowed to enter the soil or water courses or sewer systems. Ensure that hydraulic oils and fluids are disposed of safely and in an environmentally friendly way. The relevant state regulations with regard to groundwater pollution, used oils and waste must be complied with.

When working on the filter, hot oil must be expected to escape, which can cause injuries and scalding due to high pressure or high temperature.



Warning

The operator must take suitable measures (e.g. venting) to prevent the formation of air pockets.

Repair, maintenance and commissioning may be carried out only by specialised personnel¹. Only touch the filter when it has cooled down. The specifications of the operating instructions of the machine/system must be observed.

Observe statutory accident prevention regulations, safety regulations and safety data sheets for fluids.

If electrical clogging indicators are used, the system must be de-energised before removing the clogging indicator plug.



Info

This filter may be used only in conjunction with a machine or system.

The filter may be used only as intended in accordance with the operating instructions for the machine or system.

This filter may be operated only with hydraulic or lubricating fluid.

The obligations of the owner under the Federal German Water Act (WHG) / State Water Act (LWG) or other national regulations must be observed.

11.8 ELEMENT CHANGE INTERVAL

We generally recommend changing the filter element after one year of operation at the latest.

The filter should be equipped with a clogging indicator to monitor the filter element. If the clogging indicator responds, the filter element must be changed without delay.

If no external clogging indicator can be fitted, we recommend changing the elements at set intervals (the element change depends on the filter design and the conditions at the filter). When filter elements are subject to high dynamic loading, it may prove necessary to change them more frequently. The same applies in the case of commissioning, repairs, oil change etc. at the hydraulic system.

11.9 CUSTOMER INFORMATION IN THE CONTEXT OF THE MACHINERY DIRECTIVE 2006/42/EC

Hydraulic filters are fluid power parts / components and are therefore excluded from the scope of the Machinery Directive. They are not CE labelled.

The information in this HYDAC Filtertechnik GmbH documentation must be observed when using the components.

These also contain information on the basic health and safety requirements to be applied by the user (based on the Machinery Directive 2006/42/EC).

We hereby declare that the filters are intended for installation in a machine within the meaning of the Machinery Directive 2006/42/EC.

Commissioning of the filters is prohibited until the machine as a whole complies with the provisions of the Machinery Directive. You can also find our general terms and conditions of sale and delivery on our homepage (www.hydac.com).

¹ Specialised personnel/electrician:

These persons have the appropriate professional training and several years of professional experience. They are able to assess and carry out the work assigned to them and recognise potential hazards.

NOTE

The information given in this brochure refers to the described operating conditions and applications.

For applications and operating conditions not described, please contact the relevant technical department. Subject to technical modifications.

Only if original HYDAC parts are used and the work has been carried out professionally can a warranty claim be made under our terms and conditions of sale and delivery!

EXCLUSION OF LIABILITY

We have compiled these assembly instructions to the best of our knowledge and belief. Nevertheless, it cannot be ruled out that errors may have crept in despite the utmost care.

We therefore ask for your understanding that, unless otherwise stated below, we exclude our warranty and liability – regardless of the legal grounds – for the information in these installation instructions.

In particular, we are not liable for loss of profit or other financial losses.

This exclusion of liability does not apply in cases of intent or gross negligence. Moreover, it does not apply to defects which have been deceitfully concealed or whose absence has been guaranteed, nor in cases of culpable harm to life, physical injury and damage to health. If we negligently breach any material contractual obligation, our liability shall be limited to foreseeable damage. Claims arising from product liability remain unaffected.

HYDAC FILTERTECHNIK GMBH

Industrial area

66280 Sulzbach/Saar, Germany

Tel.: +49 68 97 509-01

E-mail: filter@hydac.com

Website: www.hydac.com